

A NEW TWO LEGS MOBILE ROBOT FOR INSPECTION OF POWER TRANSMISSION LINES

Thiago Martins de Deus

Federal University of Uberlândia
School of Mechanical Engineering
Campus Santa Mônica
38400-902 Uberlândia /MG, Brasil
e-mail: thiagomartinsdedeus@yahoo.com.br

Arnon Jadir Rodrigues Alves

e-mail: arnonjra@hotmail.com

João Carlos Mendes Caralho

e-mail: jcmendes@mecanica.ufu.br

Rogério Sales Gonçalves

e-mail: rsgoncalves@mecanica.ufu.br

Abstract. This paper presents a new two legs mobile robot to be used in the inspection and maintenance of the power transmission lines. First is performed a revision of existing robots and presented the main obstacles in power transmission lines. After, is presented the robot characteristics and the proposed methodologies to transpose/surmount obstacles. Finally three-dimensional graphic simulations of the robot are presented.

Keywords: Robotics, Mobile robots, Transmission lines.

1. INTRODUCTION

Many theoretical and experimental studies have been made in order to develop autonomous machines to travel along transmission lines to perform inspection and/or repair works. These machines can improve the efficiency, reduce labor and are expected to reduce any danger to maintenance personnel. Locomotion is essential for these machines that can be achieved by several methods. In spite of theoretical researches and technological developments, problems related to stability, ability and autonomy still exist.

Two types of autonomous or semi-autonomous systems can be identified. The first one uses lift vehicles where at its extremity is installed a manipulator. These systems cannot be used in inaccessible places such as valleys, rivers and mountain regions, and lines higher than the operation range of the crane arm. Although these systems are commonly used they present problems related to mobility, controllability and accessibility, and basically are applied to repair insulators (Elizondo *et al.*, 2010).

The second type is composed by mobile robots that move suspended on wire, which, in its turn, should move stably, and at the same time having a simple control, mainly for towers transposition. Wheels are the simplest way for locomotion but the wheeled robot encounter problems to cross the obstacles along the cable such as clamps and vibration dampers. Several works have been developed involving algorithms for robot control and mechanical configuration, where a review of these systems can be found in (Gonçalves, 2006; Gonçalves and Carvalho, 2008; Toussaint *et al.*, 2009).

One of the major obstacles for this kind of mobile robots are the towers. In Brazil where there are long stretches without cities is essential to overcome the towers. Moreover, the design of robots for inspection of power transmission lines in Brazil must take into account different types of obstacles and towers, as shown next section, it should move at least 100 km (average distance between the Brazilian cities) and, if possible, it should make some kind of maintenance.

The robot that travels on the energized line can use a suspended insulator to perform the tower transposition like proposed by (Gonçalves and Carvalho, 2008), (Souza *et al.*, 2004), and (Pouliot and Montambault, 2008) or can form a path (bridge) in which the robot travels like proposed by Li and Ruan (2010). However these robots have transposition problems when they found towers like presented in Fig. 2(b).

The development of an autonomous mobile robot for inspection and maintenance of transmission lines is an open research field. The major difficulty is related to the robot design due to variety of types of obstacles present in the network and its dimensions. Thus, this paper presents a new mobile robot to be applied in power transmission lines for its inspection and maintenance. First the main components of transmission lines and towers are presented. After, the robot and the proposed methodologies to transpose the obstacles are described. Finally three-dimensional graphical simulations of the proposed robot are presented.

2. COMPONENTS OF TRANSMISSION LINES

Transmission lines are exposed to variety of factors, such as corrosion and wind, which cause different problems, such vibrations for example, reducing the life time of the line (Nayyerloo *et al.*, 2009). For example, the Brazilian Electric Sector had a transmission grid of over 100,000 kilometers of transmission lines with voltages above 230kV.

Power lines are a dangerous environment with intensive electric and magnetic fields. Furthermore, the transmission network forms a complex system making difficult for robots to navigate on it. The simplest power lines have one conductor per phase hung on insulator strings (3), which can be either suspension (4) or strain insulators. Besides insulators, there are other obstacles on the conductors, such as vibration dampers (5), signaling spheres (7), and clamps. In bundle power lines, which have more than one conductor per phase (1), there are even more obstacles such as spacers and spacer dampers (2) (Pouliot and Montambault, 2008). These devices, indicated in brackets, are shown in Fig. 1.

For the overhead ground wires OGW (6), i.e., the wire suspended on the top of the tower structure, there are three typical obstacles which each type has different spatial structure (Li and Ruan, 2010). The first ones are the counterweights (vibration dampers) which are in major quantity. The second type of obstacle is the connection between the wire and the tower, Fig. 2(b). The third obstacles are the signaling spheres. Therefore, the robot must have the ability to overcome all these obstacles. Apart from the related devices, the robot should transpose the towers that exist in several shapes and dimensions, and overcome the catenary, that can attain up to 15 degrees near the tower. Figure 2 shows some details of the high voltage tower, illustrating the difficulty for designing a mobile robot to transpose it.

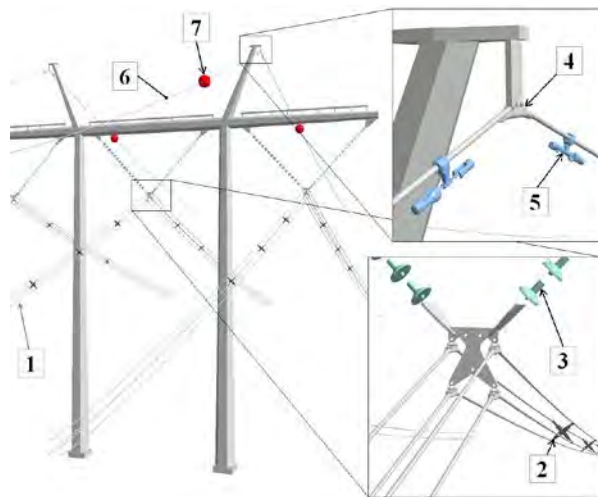

Figure 1. Typical architecture and line components of a power transmission (Pouliot and Montambault, 2008)



(a)

(b)

Figure 2. Example of towers

3. A TWO LEGS AUTONOMOUS ROBOT TO BE APPLIED IN POWER TRANSMISSION LINES

The structure of the proposed mobile robot was defined by considering characteristics such as stability, simplicity and the obstacles types and its dimensions.

A single-line sketch of the robot is shown in Fig. 3, where its movement is carried out by wheels. The structure of the robot consists of two legs where each leg has four degrees of freedom – dof. where the first ones is responsible for moving the robot along the suspended cable; the second dof. corresponds to the extension/contraction of the leg, allowing the obstacles crossing and to overcome the cable catenary; the third dof. allows the robot to rotate about the axis of a leg, with the other leg attached to the cable, providing more flexibility to transpose obstacles and the tower and, the fourth dof. allows the decoupling of the robot foot and the cable, Fig. 4(a).

Figure 4 shows a three-dimensional sketch of the leg and foot of the proposed robot and, Fig. 5 the built foot for the prototype.

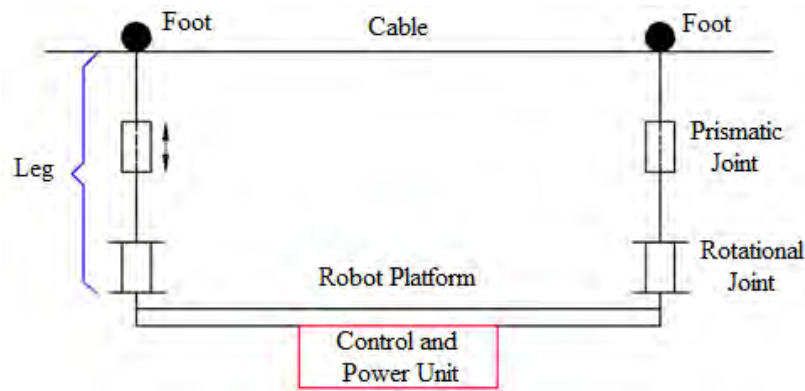

Figure 3. Sketch of the proposed mobile robot

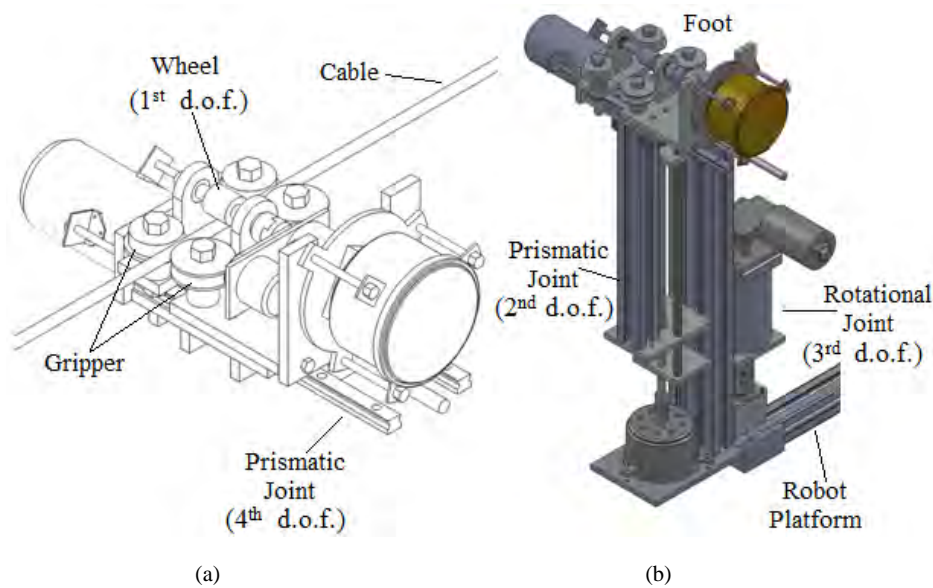

Figure 4. (a) The sketch of the foot for the proposed mobile robot; (b) The robot leg

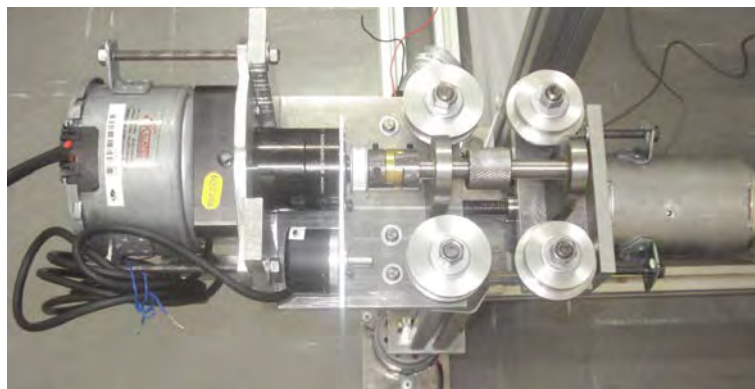

Figure 5. The built foot for the prototype of the mobile robot

4. METHODOLOGIES FOR SURMOUNTING OBSTACLES

For obstacles transposition two methodologies are used. The first methodology is applied for obstacles such as spacers, spiral bird diverters, chain suspension, insulators chain and vibration dampers. After the obstacle has been identified by a camera or a proximity sensor the robot stops and the foot, near to the obstacle, is decoupled from cable, leaving its leg free. Then, this free leg is shortened according to the maximum size of the identified obstacle, and the robot moves by using only one leg/foot that is fixed on the cable. When the obstacle is crossed, the leg returns to its original length and its foot is fixed to the cable. The another leg/foot repeats the same sequence. This procedure is used to overcome towers using insulators as shown in Fig. 2(a).

The second methodology is applied for transposition of the signaling spheres and towers which cable changes its direction. After the obstacle has been identified by a camera or proximity sensors the robot stops and the rear foot is decoupled from the cable. In this methodology the foot works like a wheel for locomotion and assumes the behavior of gripper to transpose obstacles. The robot foot is gripped to the cable through four pulleys, Fig. 4(a), that presses the cable. Then the free leg length is reduced to enable decoupling the foot of the cable. After this, the rotational joint, Fig. 4(b), is actuated in such way the robot body rotates around the obstacle. When the obstacle is overcome by the rear leg, the leg return to its original length and the foot is fixed to the cable again. The other leg repeats this same sequence. It should be noted that usually the signaling spheres are attached to the overhead ground wire, Fig. 1. This same procedure can be used too for crossing obstacles such as spacers, spiral bird diverters, chain suspension, chain insulators and vibration dampers.

In order to visualize the robot behavior were carried out graphical simulations using the software SolidWorks and VisualNastran Desktop 4D[®] that enable kinematic and dynamic simulations through a constructed solid model and virtual constraints.

Figure 6 shows the proposed robot surmounting a signaling sphere and in Fig. 7 transposing a tower and vibration damper. In both cases the second methodology is used.

In Figure 6(a) the signaling sphere was detected, then, the rear foot is decoupled from the cable and the free leg length is reduced, Fig. 6(b). The base rotational joint is actuated and the body of the robot turns around the obstacle, Fig. 6(b). After the rotation, the leg returns to its original length and the foot is attached to the cable, Fig. 6(c). The other leg repeats the same sequence and the robot transpose the obstacle, Figs. 6(d,e). The same procedure is applied in Fig. 7 to transpose a vibration damper and the tower.

5. CONCLUSIONS

As related in several works about robots applied in power transmission lines, the most of them present problems related to controllability and ability to surmount/transpose obstacles. Although much work has been achieved in the past two decades, considerable developments still need in order to obtain a reliable autonomous robot for performing the inspection and maintenance of power transmission lines.

Thus, this paper presented a new two legs mobile robot to be applied for maintenance and inspection of power transmission lines which methodologies for transposition of obstacles and towers were described. Finally, three-dimensional graphics simulations were presented showing the feasibility of using the robot on power transmission lines.

Next step of the work consists on experimental tests and control system implementation for the built prototype.

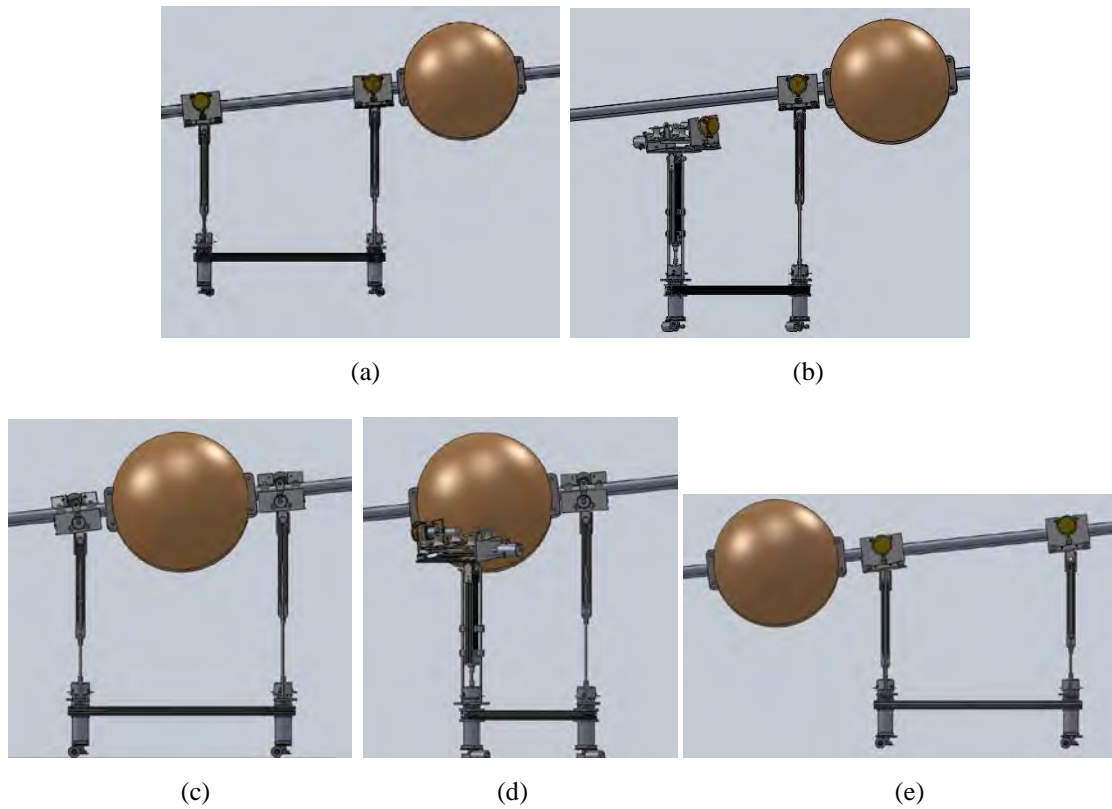

Figure 6. The proposed mobile robot surmounting a signaling sphere

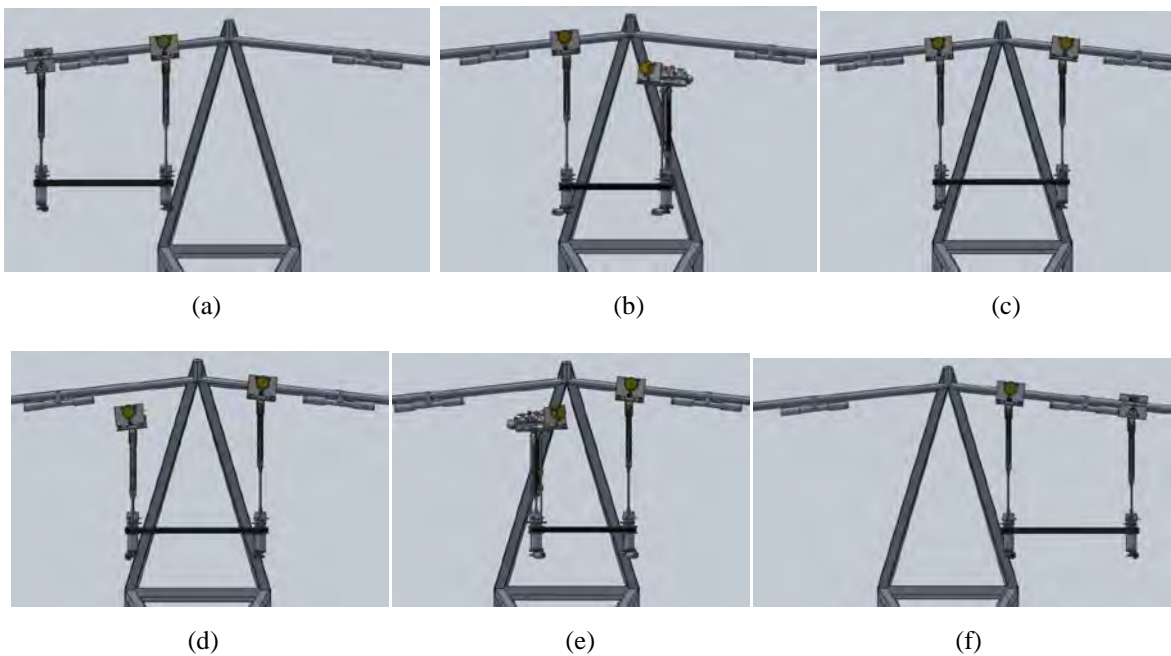

Figure 7. The proposed mobile robot transposing a tower and a vibration damper

6. ACKNOWLEDGEMENTS

The authors are thankful to CAPES, UFU, FEMEC, CNPq and FAPEMIG (process APQ-01999-10) for the partial financing support of this research work.

Patent Application nº BR 10 2012 011165-9.

7. REFERENCES

- Elizondo, D., Gentile, T., Candia, H. and Bell, G., 2010. "Ground based robots for energized transmission line work-technology description, field projects and technical-economical justification on their application". In *Proceedings of Transmission and Distribution Conference and Exposition: Latin America*, p. 700-705. São Paulo, Brazil.
- Gonçalves, R.S., 2006. "A Mobile Robot Suspended by Wire with Variable Length Legs". (In Portuguese), M. Sc. Dissertation, Federal University of Uberlândia, Brazil, 116 p., <<http://repositorio.ufu.br/handle/123456789/52>>.
- Gonçalves, R.S., Carvalho, J.C.M., 2008. "A Legged Robot Suspended on Wire for Transposition of Insulators and Signalizing Spheres". In *proceedings of the 3rd International Symposium on Multibody Systems and Mechatronics – MuSMe 2008*. San Juan, Argentina.
- Li, Z. and Ruan, Y., 2010. "Autonomous Inspection Robot for Power Transmission Lines Maintenance While Operating on the Overhead Ground Wires". *International Journal of Advanced Robotic Systems*, Vol. 7, n° 4, p. 111-116.
- Nayerloo, M., Chen, X., Wang, W. and Chase, G., 2009. "Cable-Climbing Robots for Power Transmission Lines Inspection". *Mobile Robots – State of the Art in Land, Sea, Air, and Collobarative Missions*, Chapter 4. Publisher InTech.
- Pouliot, N. and Montambault, S., 2008. "Geometric Design of the LineScout, a Teleoperated Robot for Power Line Inspection and Maintenance". In *Proceedings of the IEEE International Conference on Robotics and Automation*. Pasadena, USA.
- Souza, A., Moscato, L.A., Santos, M.F., Vidal Filho, W.B., Ferreira, G.A.N. and Ventrella, A.G., 2004. "Inspection Robot for High-Voltage Transmission Lines". *ABCMSymposium Series in Mechatronics*. Vol 1, p. 1-7, <http://www.abcm.org.br/symposiumSeries/SSM_Vol1/ssMechatronics.shtml>.
- Toussaint, K., Pouliot, N. and Montambault, S., 2009. "Transmission Line Maintenance Robots Capable of Crossing Obstacles: State-of-the-Art Review and Challenges Ahead". *Journal of Field Robotics*, Vol 26, n° 5, p. 477-499.

8. RESPONSIBILITY NOTICE

The authors are the only responsible for the printed material included in this paper.