

# STABILITY ANALYSIS OF FUZZY CONTROLLERS USING THE MODIFIED POPOV CRITERION

**Mauricio Gonçalves Santana Junior**

Instituto Tecnológico de Aeronáutica Pça Mal Eduardo Gomes, 50 Vila das Acácias - CEP 12228-900 São José dos Campos - SP  
mauricio@ele.ita.cta.br

**Karl Heinz Kienitz**

Instituto Tecnológico de Aeronáutica  
kienitz@ieee.org

**Abstract.** This paper deals with the stability analysis of fuzzy logic control (FLC) systems. The output characteristic of this class of controllers is nonlinear, thus it is necessary to use stability analysis methods for nonlinear systems. Here we use the Popov criterion. The systems analysed have a FLC with two input variables and one output variable, resulting in a surface as the nonlinear output characteristic. Using algebraic and graphic manipulation of the control system state equations and of the nonlinear output characteristic of the FLC, we can apply the Popov criterion to systems with this configuration.

**Keywords.** Fuzzy logic, stability, Popov criterion.

## 1. Introduction

The concept of a fuzzy set was introduced by Lotfi A. Zadeh (University of California, Berkeley), in 1965. He observed that the available technological resources were insufficient to automate the activities related to the problems of industrial, biological or chemical nature, that includes ambiguous situations.

Fuzzy set theory provides a method of translating verbal, imprecise and qualitative expressions, common in human communication, in numerical values. Thus, we can express human knowledge in a way that the computers can process. Therefore, systems that use fuzzy set theory are called by *intelligent*, because they emulate some aspects of human intelligence.

When fuzzy set theory is used in the logic context, for example in knowledge based systems, it is known as *fuzzy logic*.

The fuzzy logic controller designer needs a large knowledge of the imprecision and the uncertainties in industrial processes and plants and how they affect the usual applications of modern control theory (Shaw et al, 1999).

The techniques of fuzzy control originated with the research of E. H. Mamdani (1974), of Queen Mary College, London University. In 1974 he controlled a steam machine using fuzzy reasoning.

To enhance the power of the framework of fuzzy control, it is desirable to demonstrate the stability of fuzzy systems, but this may not be straightforward. In this paper we are concerned with a stability analysis tool for a particular class of fuzzy systems.

When we have the mathematical model of the control system, we can make the stability analysis. The output characteristic of fuzzy logic controllers is nonlinear. In very specific cases it can be linear. Therefore, we need to use stability analysis methods for nonlinear systems. The stability analysis tool discussed here is based on Popov criterion. It is applied to fuzzy logic controllers (FLC) with two inputs and Mamdani implication. Thus we present and we discuss a modification of the Popov criterion introduced by Bühler (1994).

## 2. Popov criterion

Consider a closed loop system composed by a nonlinearity (NL) without memory in cascade with a linear plant (L). The stability of this system can be determined based on its frequency response, using the Popov criterion (Tomovic, 1966):

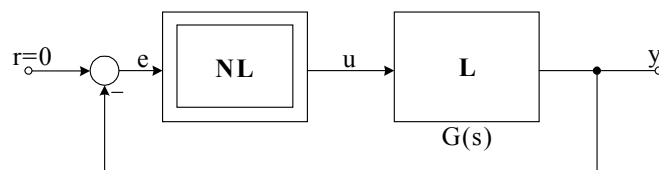

Figure 1. Basic structure for the application of the Popov criterion.

$$\dot{x} = A \cdot x + b \cdot u \quad ; \quad y = C \cdot x \quad ; \quad u = -f(t, y) \quad (1)$$

where  $A$  is the state matrix,  $b$  is the input vector,  $C$  is the output matrix,  $u$  is the controller's output,  $x$  is the state vector and  $y$  is the system's output. Suppose that  $A$  is Hurwitz,  $(A, b)$  is controllable,  $(A, C)$  is observable and  $f(\cdot)$  is a *time-invariant* nonlinearity that satisfies the condition (Santana Jr, 2003):

$$[f(y) - K_{\min} \cdot y]^T [f(y) - K_{\max} \cdot y] \leq 0 \quad \forall y \in \Gamma \subset \mathbb{R}^p \text{ and } K_{\min} = 0 \quad (2)$$

where  $K$  is a positive definite symmetric matrix. Consider a Lyapunov function candidate of the Lure-type:

$$V(x) = x^T P \cdot x + 2 \cdot \eta \int_0^y f(\sigma) \cdot K \cdot d\sigma \quad (3)$$

where  $\eta \geq 0$ . Using the Kalman-Yakubovitch lemma (Yoneyama et al, 2002), we can show that an enough condition for stability is the existence of  $q > 0$  such that:

$$\operatorname{Re}[1 + q \cdot j\omega] \cdot G(j\omega) + \frac{1}{k} > 0 \quad \forall \omega \in \mathbb{R} \quad (4)$$

where  $G(j\omega)$  is the frequency response of the system. This condition can be represented graphically.

$$G^*(\omega) = X + j \cdot Y \quad \text{where} \quad X = \operatorname{Re}[G^*(j\omega)] = \operatorname{Re}[G(j\omega)] \quad \text{e} \quad Y = \operatorname{Im}[G^*(j\omega)] = \omega \cdot \operatorname{Im}[G(j\omega)] \quad (5)$$

Therefore, for absolute stability, the Eq. (4) can be expressed by:

$$X - q \cdot Y + 1/k = 0 \quad (6)$$

The Eq. (6) is a straight line equation, with slope  $1/q$  and passing through the point  $-1/k$ . This straight line is called Popov's line. The Eq. (4) is satisfied if the Popov plot  $G^*(j\omega)$  lies entirely to the right of this line. The slope  $q$  can take any real, positive value.

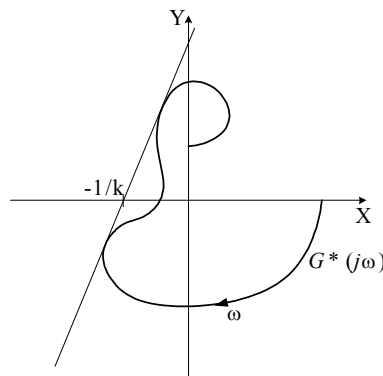

Figure 2. Geometrical interpretation of the Popov criterion.

Thus, it is possible to find the factor  $k$ , which defines, according to the Fig. (3), the sector of absolute stability:

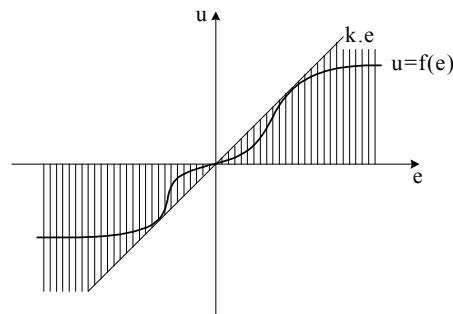

Figure 3. Zone  $0 < f(e) < k \cdot e$  containing the nonlinear characteristic  $u = f(e)$ .

### 3. Modification of the Popov criterion

To use the Popov criterion in the stability analysis of a fuzzy control system, it is of advantage to modify this criterion slightly:

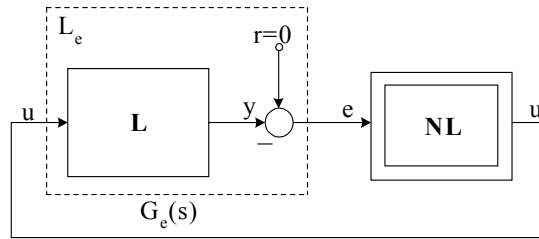

Figure 4. Modified structure for application of the Popov criterion.

We change the position of the linear (L) and nonlinear (NL) blocks of Fig. (1), and we obtain the outline shown in Fig. (4). Thus, we analyse the control error  $e = r - y$  belonging to block  $L$ , and we determine a new block, which is called  $L_e$ . Therefore, its transfer function becomes:

$$G_e(s) = -G(s) \quad (7)$$

Because of the signal inversion, the Popov criterion given by Eq. (6) is then defined by:

$$X_e(j\omega) - qY_e(j\omega) - 1/k < 0 \quad (8)$$

The Popov's line is given by:

$$X - q \cdot Y - 1/k = 0 \quad (9)$$

Thus, for stability assurance, the Popov plot  $G_e^*(j\omega)$  must be placed to the left of Popov's line, as it is shown in Fig. (5):

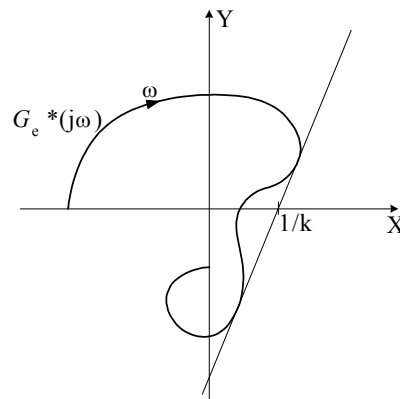

Figure 5. Geometric interpretation of the modified Popov criterion.

## 4. Fuzzy logic control system and the Popov criterion application

### 4.1. General relationships

The Fig. (6) presents the fuzzy control system base structure with the linear system. This linear system is called  $S$ , and the fuzzy logic controller is represented by the block **FLC**:

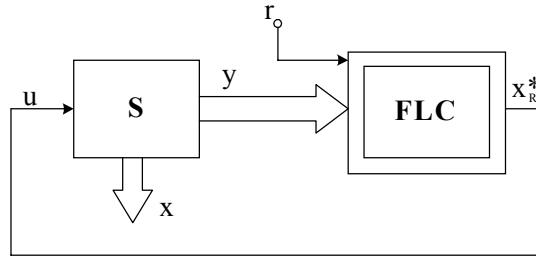

Figure 6. Fuzzy system base structure.

The *linear system* can be described by the following *state equation*:

$$\dot{x} = A \cdot x + b \cdot u \quad (10)$$

where the state vector  $x$  has the dimension  $n$ . The output variables are in the vector  $y$  and they are given by:

$$y = C \cdot x \quad (11)$$

They are applied to the **FLC** inputs with the reference  $r$ . The state vector  $x$  is given by:

$$x = \begin{bmatrix} x_{s1} \\ x_{s2} \\ x_{s3} \end{bmatrix} \quad (12)$$

The states  $x_{s1}$  and  $x_{s2}$  are used to compose the **FLC** inputs. The vector  $x_{s3}$  contains all the other states.

The state vector  $x_e$  composes the input variable of the **FLC** and the state equation of the system to control is given by:

$$\dot{x}_e = A_e \cdot x_e + b_e \cdot x_R^* \quad (13)$$

where  $u$  is changed by the **FLC** output  $x_R^*$ . So, we need to apply the following linear transformations:

$$x_e = T \cdot x \quad ; \quad A_e = T \cdot A \cdot T^{-1} \quad ; \quad b_e = T \cdot b \quad (14)$$

The matrix  $T$  is determined so that the tangent plane in the origin of the characteristic of the **FLC** attributes the same output signal of  $x_R^*$  in the domains of  $x$  and  $x_e$ . This tangent plane corresponds to the output characteristic of the *feedback state controller* (Bühler, 1994).

$$u = k_{s1} \cdot (r - x_{s1}) - k_{s2} \cdot x_{s2} \quad (15)$$

where  $r - x_{s1}$  corresponds to the error of the state feedback control. The line vector  $k_s^T$  is defined from (15):

$$k_s^T = [k_{s1} \quad k_{s2}] \quad (16)$$

In the **FLC** base system, the control error  $e = r - y_1$  is formed from  $y_1$  and together with the other element  $y_2$ , it becomes the vector  $x_e$ , with dimension  $n_e = 2$ . So, we use the following linear transformation (Bühler, 1994):

$$x_e = T_e \cdot y \quad (17)$$

For the matrix  $T_e$ , there is the following condition (Bühler, 1994):

$$k_s^T \cdot y = k_e^T \cdot x_e = k_e^T \cdot T_e \cdot y = k_e \cdot e_e^T \cdot T_e \cdot y \quad (18)$$

There is also the introduction of the vector  $e_e^T$ , with dimension  $n_e = n_s = 2$ :

$$e_e^T = [-1 \quad 1] \quad (19)$$

We can see that the first element has a negative signal, because  $x_{e1}$  is proportional to the control error. So, the matrix  $T_e$  becomes:

$$T_e = \begin{bmatrix} -k_{s1}/k_e & 0 \\ 0 & k_{s2}/k_e \end{bmatrix} \quad (20)$$

With the vector  $x_e$ , we can modify the control system base structure, as shown in Fig. (7). The reference  $r$  does not appear clearly. Therefore, the *control system is autonomous*.

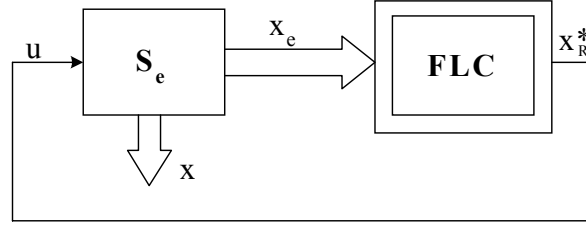

Figure 7. Modified structure of the **FLC** system (first modification).

#### 4.2. Nonlinear function of FLC

The **FLC** output  $x_R^*$  is a *nonlinear function* of the input vector  $x_e$ , given by:

$$x_R^* = f(x_e) \quad (21)$$

The nonlinear function  $f(\cdot)$  must respect some conditions:

$$\left. \begin{array}{l} x_R^* = 0 \text{ para } e_e^T \cdot x_e = 0 \\ x_R^* > 0 \text{ para } e_e^T \cdot x_e < 0 \\ x_R^* < 0 \text{ para } e_e^T \cdot x_e > 0 \end{array} \right\} \quad (22)$$

Finally, for small values of the vector  $x_e$ , it is necessary that the nonlinear function approaches of a linear relationship defined as (Bühler, 1994):

$$x_R^* = -k_e \cdot e_e^T \cdot x_e = -k_s^T \cdot y \text{ para } x_e \rightarrow 0 \quad (23)$$

Thus, at the limit of the origin, the nonlinear characteristic of the **FLC** behaves as a feedback control. The nonlinear functions of the **FLC** respect those conditions, as well as it happens with the feedback control (Bühler, 1994).

#### 4.3. Nonlinear transformation of the input variables of the FLC

To use the Popov criterion with a **FLC** with two inputs ( $n_e = 2$ ), we need to introduce a linear transformation to the vector  $x_e$ . We promote a rotation of  $45^\circ$  in the axes of the output characteristic of the **FLC**. Thus we obtain new axes  $x_{t1}$  and  $x_{t2}$  and we change the their scales. The method is illustrated by the Fig. (8):

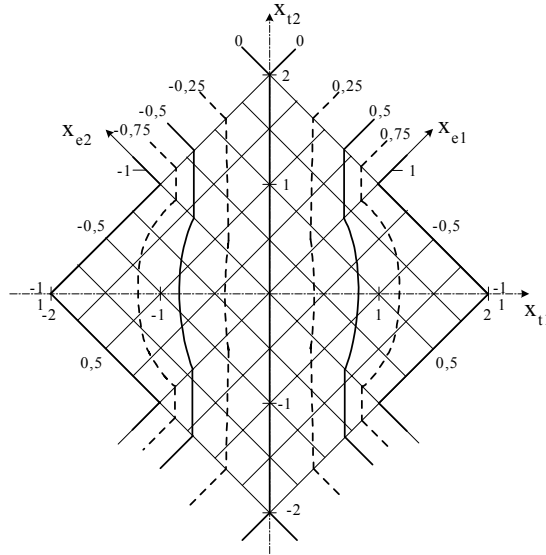

Figure 8. Linear transformation of the FLC input.

There are the following general relationships between the vectors  $x_e = [x_{e1} \ x_{e2}]^T$  e  $x_t = [x_{t1} \ x_{t2}]^T$  (Bühler, 1994):

$$x_t = T_t \cdot x_e ; x_e = T_t^{-1} \cdot x_t \quad (24)$$

Therefore, the transformation matrix must be:

$$T_t = \begin{bmatrix} 1 & -1 \\ 1 & 1 \end{bmatrix} \quad (25)$$

Thus, the behavior at the limit  $x_e \rightarrow 0$  (origin) of the nonlinear characteristic, according to Eq. (23), it becomes:

$$x_R^* = -k_e \cdot c_e^T \cdot T_t^{-1} \cdot x_t = k_e [1 \ -1] \cdot \begin{bmatrix} 1/2 & 1/2 \\ -1/2 & 1/2 \end{bmatrix} \cdot x_t = k_e \cdot x_{t1} \quad (26)$$

that is, the slope of the tangent in the origin of the characteristic, in relation to the axis  $x_{t1}$ , is given by:

$$k_e = \frac{x_R^*}{x_{t1}} \quad (27)$$

We can observe that the behavior at the limit ( $x_t \rightarrow 0$ ) does not depend of the variable  $x_{t1}$ . Continuing the computation of the nonlinear characteristic  $x_R^* = f(x_e) = f(x_t)$ , we introduce the following relationship (Bühler, 1994):

$$x_R^* = k_R \cdot x_{t1} \quad (28)$$

where  $k_R$  is a nonlinear function of  $x_t$ , given by:

$$k_R = f(x_t) = \frac{x_R^*}{x_{t1}} \quad (29)$$

The value  $k_R$  does not depend only of  $x_{t1}$ , but it also depends on the other elements of vector  $x_t$ . According to the nonlinear characteristic given this factor changes among rights limits which determine a sector where this characteristic must be located.

The value  $k_R$  indicates the slope of the hyperplane, which cross the origin of the space ( $x_t, x_R^*$ ). This hyperplane has the same coordinates that the nonlinear function at the operational point. Thus, we need to calculate the values  $k_R$  for all the points, using the Eq. (29).

#### 4.4. Fuzzy logic control system modified structure

Now we can modify the fuzzy logic control system structure. Thus, we consider that the control system (called now by  $S_t$ ) has the variable  $x_{t1}$  as the only output variable. See Fig. (9). However, the variable  $x_{t2}$  also acts on the **FLC**.

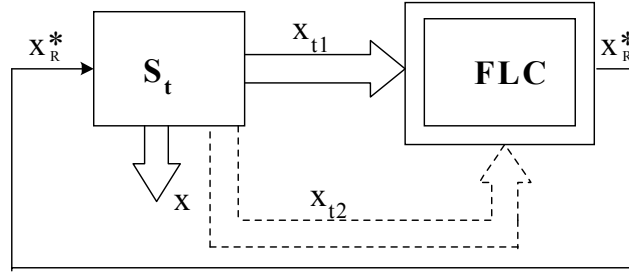

Figure 9. Modified structure of the **FLC** system (second modification).

Thus, we analyse the **FLC** with two inputs as a **FLC** with one input. Therefore, his output characteristic is studied as a function of the space  $(x_{t1}, x_R^*)$ . The state-space equation and the output equation of the  $S_t$  are given by:

$$\dot{x} = A \cdot x + b \cdot x_R^* \quad (30)$$

$$x_{t1} = -\frac{1}{k_e} \cdot c_t^T \cdot x \quad (31)$$

First of all, we generalize the Eq. (26) to determinate the line vector  $c_t^T$  (Bühler, 1994):

$$-k_e \cdot e_e^T \cdot T_t^{-1} \cdot x_t = k_e \cdot x_{t1} = k_e \cdot [1 \ 0] \cdot x_t \quad (32)$$

thus we can conclude that:

$$[1 \ 0] \cdot T_t = -e_e^T \quad (33)$$

Considering Eq. (24), Eq. (17), Eq. (18) and Eq. (11), we can make successively the following transformations:

$$x_{t1} = [1 \ 0] \cdot x_t = [1 \ 0] \cdot T_t \cdot x_e = -e_e^T \cdot T_e \cdot y = -\frac{1}{k_e} \cdot k_s^T \cdot C \cdot x \quad (34)$$

A comparison with Eq. (31) shows that:

$$c_t^T = k_s^T \cdot C \quad (35)$$

#### 4.5. Transfer function of the modified control system and the Popov criterion

By comparison of the Fig. (9) and Fig. (4), we can see that modified system structure of the **FLC**, according to the section IV.4.3, it corresponds to the structure modified by the application of the Popov criterion, according to the section IV.3. Thus, we can use the Popov criterion given by Eq. (8), to analyze the stability of the **FLC**.

According to the structure of the Fig. (9), the control system  $S_t$  is described by Eq. (30) and Eq. (31). By the existent relationships between the state equations and the transfer function, we can find the following transfer function for the modified system:

$$G_t(s) = \frac{x_{t1}(s)}{x_R^*(s)} = -\frac{1}{k_e} \cdot c_t^T \cdot (s \cdot I - A)^{-1} \cdot b = -\frac{1}{k_e} \cdot k_s^T \cdot C \cdot (s \cdot I - A)^{-1} \cdot b \quad (36)$$

For a concrete case, we can compute the frequency response  $G_t(j\omega)$ , ( $s = j\omega$ ), and then, we can compute the Popov plot  $G_t^*(j\omega)$  of the modified system.

Thus, we can determinate the Popov's line, as in the Fig. (5), and we can obtain the factor  $k$ , which defines the section where the nonlinear characteristic must be located to ensure the absolute stability of the nonlinear closed loop system. The nonlinear characteristic of the **FLC** is given by:

$$x_R^* = f(x_t) = k_R \cdot x_{t1} \quad (37)$$

As we already explained, the factor  $k_R$  is a nonlinear function of  $x_{t1}$  e  $x_{t2}$ . Thus, there is the situation presented by the Fig. (10). The straight line  $k_R \cdot x_{t1}$  cross the operation point of the nonlinear function  $x_R^* = f(x_t)$ .

The nonlinear control stability is guaranteed if Eq. (36) is satisfied. Then, we have the condition:

$$0 < k_R < k \quad (38)$$

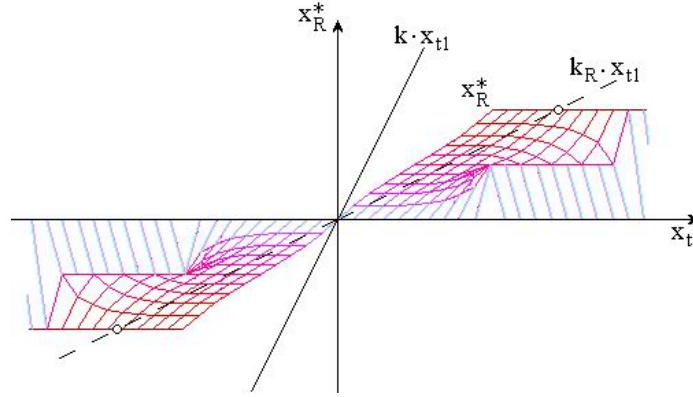

Figure 10. Nonlinear characteristic of FLC inside a sector  $0 \leq x_R^*(x_{t1}) \leq k \cdot x_{t1}$ .

#### 4.6. Discussion on the Popov criterion presented by Bühler (1994)

In the previous sections we showed the description of the Popov criterion, and we saw that it can be applied only to a *time-invariant* nonlinear function. However, when we apply the Popov criterion to a modified fuzzy system, the input  $x_{e2}$  is a derivative of the position “y” and so the output of the CN is a nonlinear time-variant function. Then the modification presented by Bühler is not appropriate.

#### 5. Results

Here we study the modified Popov criterion application for a linear plant that satisfies all the conditions introduced previously. The state-space model of the system is given by:

$$A = \begin{bmatrix} 0 & 1 \\ -1 & -0.1 \end{bmatrix}, b = \begin{bmatrix} 0 \\ 1 \end{bmatrix}, C = [1 \quad 0]$$

The poles of this system are:  $s = -0,05 + 0,9987*i$  e  $s = -0,05 - 0,9987*i$ . Every poles have negative real parts and the system is controllable and observable. Therefore, the Popov criterion can be applied to this system.

To control this system, we chosen the function shown below:

$$u = -K(x_{s1}, x_{s2}) y$$

Where:

$$K(x_{s1}, x_{s2}) = \left| \frac{x_{s1} - x_{s2}}{1 + |x_{s1}| + |x_{s2}|} \right| \quad 0 \leq K(x_{s1}, x_{s2}) \leq 1 \quad \forall x_{s1}, x_{s2} \in \mathfrak{R}$$

So this nonlinear function respects all the conditions (22). The nonlinear characteristic and the tangent plane at the origin of this characteristic are shown in the Fig. (12):



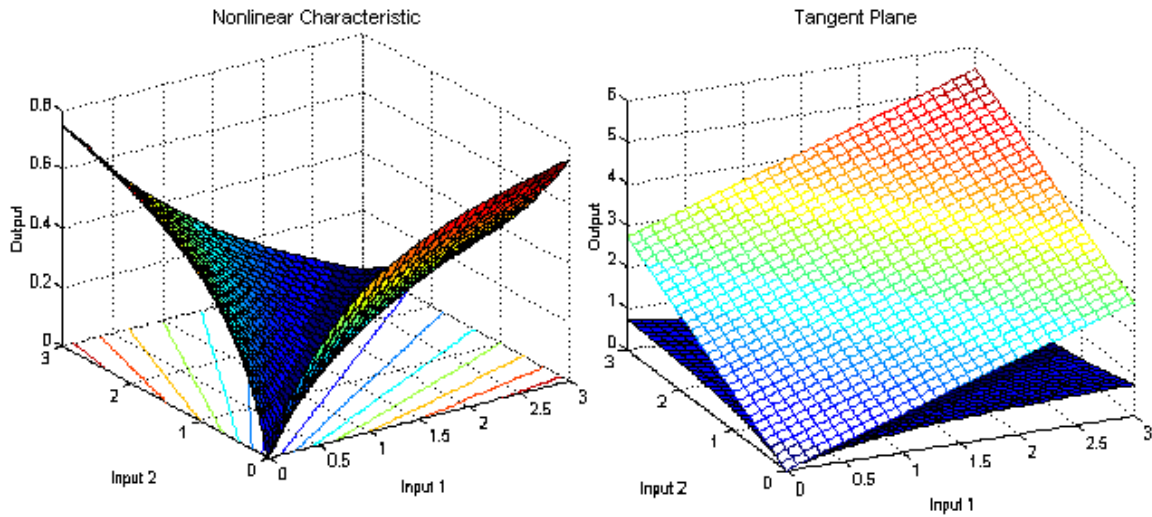

Figure 12. The controller's nonlinear characteristic and his tangent plane.

This plane is obtained from the existent points about the origin of the characteristic. From this plane equation we obtain the state line vector  $k_s^T$  and the nonlinearity parameter:

- $k_e = 0,9091$  → nonlinearity parameter (tangent plane's slope);
- $k_s^T = [0,9091 \ 0,9091]$  → line vector of the feedback state controller.

We compute now, point to point, the slope of all the points of th nonlinear characteristic. Thus, we can obtain the maximum value of the slope. In this case, the maximum slope is  $k_{Rmax} = 0,9091$ .

The modified output equations are given by (they are the **FLC** inputs):

$$y = \begin{bmatrix} 1 & 0 \\ 0 & 1 \end{bmatrix} \cdot \begin{bmatrix} x_{s1} \\ x_{s2} \end{bmatrix} \Rightarrow C = C_t = \begin{bmatrix} 1 & 0 \\ 0 & 1 \end{bmatrix}$$

From the matrix  $C_t$ , from the vector  $k_s^T$  and from the parameter  $k_e$ , together with the matrix  $A$  and  $b$  of the system to control, we obtain the transfer function of the modified system  $G_t(s)$ :

$$G_t(s) = \frac{-s-1}{s^2 + 0,1 \cdot s + 1}$$

From the  $G_t(s)$  we can draw the Popov plot and then we can obtain the Popov's line. The Fig. (13) (a) shows the Nyquist plot of the linear system and (b) shows the Popov plot.

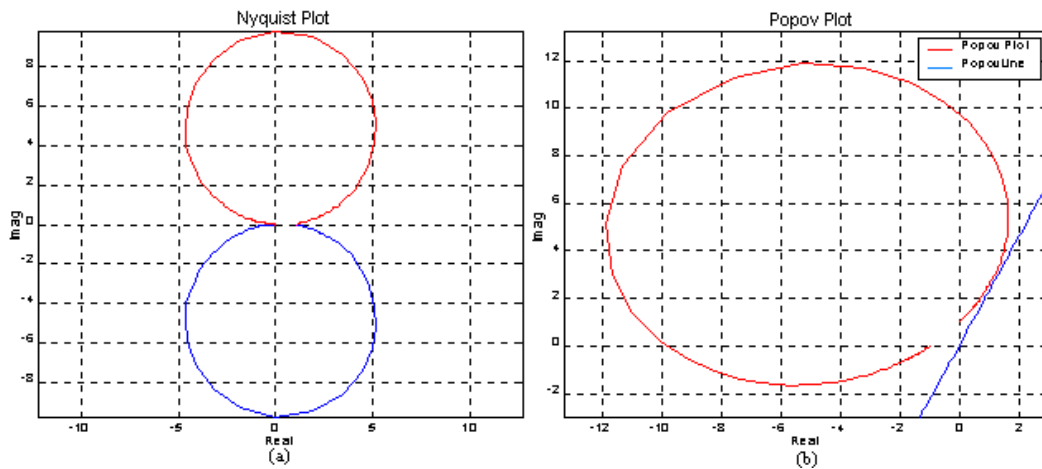

Figure 13. (a) Nyquist plot of the linear system.(b) Popov plot of the modified system.

The inverse of the intersection of Popov's line with the real axes supplies the value of the slope  $k$  of the area of stability, in which the nonlinear characteristic must be located.

$$\left| \frac{1}{k} \right| = 0,0327 \Rightarrow k = 30,5571$$

By comparison we see that the value of  $k$  is larger than the value of the slope  $k_{R_{\max}}$ , because  $k_{R_{\max}} = 0,9091 < k = 30,5571$ , so we can conclude that the system is stable. However, when this system is simulated we can observe that this system is unstable. The Fig. (14) (a) shows the simulation diagram (b) shows the position plot.

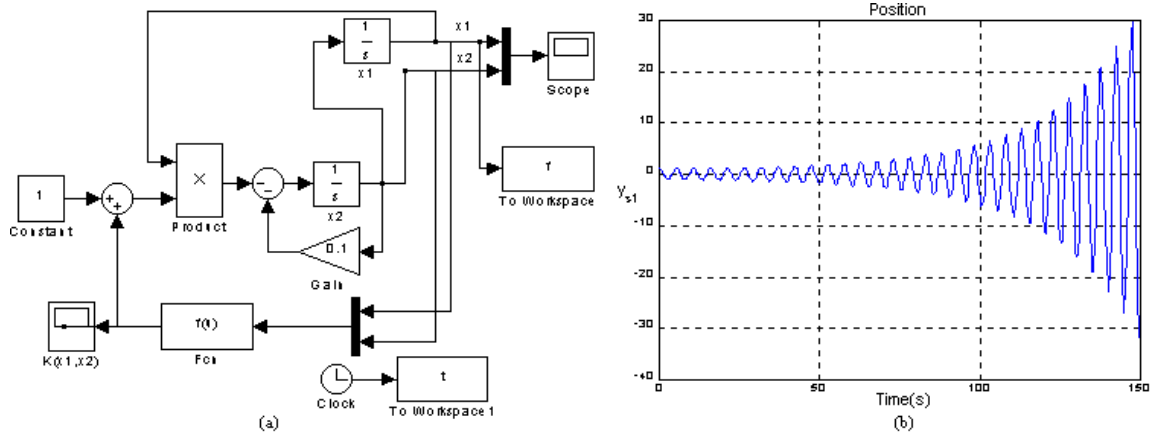

Figure 14. (a) The blocks diagram.(b) Position plot.

## 6. Conclusions

In this paper we discuss a methodology to analysis for the Popov criterion application to a FLC with two inputs and one output.

We presented the modified Popov Criterion developed by Bühler. We observe that the developed linear transformation is correct and we can apply the analysis over this transformation. However, the stability criterion chosen by Bühler is not appropriate. As we shown previously, the Popov criterion can be applied only on nonlinear time-invariant functions, and the nonlinear characteristic of FLC with two inputs and one output is a time-variant function.

We used a function that respects the conditions (22) to show that the Popov criterion can not be applied to functions like that. So, we need to find other method to analysis to apply over the linear transformations presented above.

## 7. References

- Bühler, H.,1994, “Réglage par Logique Floue”, Presses Polytechniques et Universitaires Romandes, Lausanne.
- Khalil, H. K.,1996, “Nonlinear Systems”, Ed. Prentice – Hall, Second Edition, U.S.A.
- Santana Jr, M. G., 2003, “Análise de Estabilidade de Sistemas Nebulosos Via Critério de Popov”, Tese de Mestrado, Instituto Tecnológico de Aeronáutica, São José dos Campos, Brazil.
- Shaw, I. S.; Simões, M. G.,1999, “Controle e Modelagem Fuzzy”, Ed. Edgard Blücher, First Edition, São Paulo, Brazil.
- Tomovic, R., 1966, ”Introduction to Nonlinear Systems”, Ed. John Wiley and Sons LTD, Iugoslávia.
- Faleiros, A. C.; Yoneyama, T., 2002, “Teoria Matemática de Sistemas”, Ed. Arte & Ciência, São José dos Campos, Brazil.
- Zadeh, L. A., 1965, “Fuzzy Sets”, Information and Control 8, University of California, Berkeley, U.S.A..
- Mamdani, E. H.,1974, “Application of Fuzzy Algorithms for Control of Simple Dynamic Plant”, Proc. IEE, v. 121, n 12, pp. 1585 – 1588.