

# Evaluation of a Experimental Modal Synthesis Method Using Mass Normalized Modes

**Manoel Moraes Junqueira**

Federal University of Uberlândia / FEMEC – Av. João Naves de Ávila, 2160 – Bl. 1M  
[moraes@mecanica.ufu.br](mailto:moraes@mecanica.ufu.br)

**Cleudmar Amaral Araújo**

Federal University of Uberlândia / FEMEC – Av. João Naves de Ávila, 2160 – Bl. 1M  
[cleudmar@mecanica.ufu.br](mailto:cleudmar@mecanica.ufu.br)

***Abstract.** The modal synthesis method is based on the division of great or complex structures in some lesser substructures whose modal bases are used to synthesize the dynamic information of the original system. The approach of the method can be made through numerical or experimental methods. The advantage the experimental methods are to avoid the process of the numerical modeling that is difficulty mainly in the great or complex structures. However, in some methods of experimental modal synthesis the mass-normalization is fundamental. This is obtained using a process simulated through the use of the modal residues. Unfortunately, this approach does not provide resulted satisfactory in the modal synthesis method. Hence, the process of identification of the complete structure by method of experimental modal synthesis can not be applied. This work presents the modal synthesis method SMFR used in experimental approaches and a method of identification of the mass matrices system using the experimental FRF with the objective of the to avoid the problem of the residues normalization. The two methodologies are coupled and validated through an experimental model formed by three parallel plates of aluminum and connected by sheets of steel.*

**Keywords:** Normalization, identification, experimental modal synthesis, dynamic modeling.

## 1. Introduction

The modal synthesis method bases on the division of a complex structure in several substructures whose reduced modal bases will be group and synthesized to give the modal base of the original system. The method becomes a convenient form of dynamic modeling of large and complex structures due to its modulation character, that allows an independence of the substructures with relationship to the project, facilitating individual analyses of these substructures for assembly of the complete structure. The methodology possesses flexibility as the use of the contour conditions: free, clamped or hybrid. A great advantage of the method is the possibility of analysis of each component separately, facilitating the tests and the analysis of the models.

The modal synthesis techniques can be divided in analytical/numerical and experimental. Inside of the experimental techniques, the SMFR method, Cleudmar A. A. (1998), use the modal superset of residual flexibility and it has the advantage of being a mixed technique that can be used in numeric methods as in experimental methods. In this technique it is also possible to use general damping in the analyzed models. To use this technique it is essential that the modal base is mass normalized. But when the data is purely experimental its application becomes difficult because, at first, the physical matrices of the analyzed structure are unknown. Hence, the normalization has been made using the modal residues, Richardson et al. (1977, 2000). In the work of Cleudmar A. A. (2001) this normalization process was evaluated through a lumped model mass-spring-damping. He showed that the use of the modal bases normalized in the experimental modal synthesis method could not be adequate. Hence, an alternative would be the identification of a mass matrix of the analyzed structures to be used in the conventional process of normalization of the modal bases.

In this work a technique will be presented for the estimate of the mass, stiffness and damping matrices. The main objective is the identification of the mass matrix of the system. In the method, instead of using a formulation for finite elements to calculate the mass and the stiffness, they will be used normal FRFs extracted of complex FRFs. This technique, in the domain of the frequency, is adapted for measures contaminated with noise distributed and in measured experimental data. The method was proposed by Chen et al., (1993) where were just accomplished numeric validations. In this work an experimental model is proposed to evaluate the process of the normalization through the identification of the mass matrix using the Chen method and also the SMFR modal synthesis method. The technique of modal synthesis and the Chen method were implemented in Matlab environment.

## 2. Modal Synthesis Method

The process of modal synthesis using the SMFR method was developed in the work of Cleudmar A. A. (1998). The formulation of the method is based on three basic points:

- Division of the global structure in several substructures;
- Obtaining of the modal superset (flexible modes more static modes) through an analytical or experimental formulation;
- Assembling and solving of the global equations of motions according to the imposed connectivity.

Suppose that two components (a) and (b) are joint for a common boundary, for they form a global structure, as shown in the figure 1. These substructures are modeled using internal coordinates physical ( $u_i$ ) and boundary coordinates physical ( $u_c$ ).

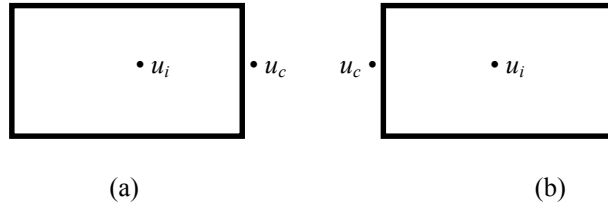

Figure 1. Substructures (a) e (b) joining at boundary.

Cleudmar A. A. (1998), developed the analysis procedures and calculation of technical SMFR that uses the residual flexibility modes defined in function of the inertia components and stiffness of the dynamic matrix, that is to say

$$\delta_f = \theta_d \Lambda_{dd}^{-1} \theta_{dc}^t \quad (1)$$

where:

$d$  e  $c$  - Unselected and boundary, respectively.

$\delta_f$  - Residual flexibility modes.

$\Lambda_{dd}$  - Unselected eigenvalues matrix.

$\theta_{dc}$  - Unselected normal modes.

The residual flexibility modes are defined as the flexible modes that are eliminated of the modal base. The unselected normal modes are obtained according to relationship,

$$\theta_{dc} = \{0 \quad f_c\} \theta_{mc} \quad (2)$$

where:

$m$  - Total number of normal modes

$f_c$  - Unitary forces applied to boundary of the substructures.

Being defined the selected or maintained normal modes of the modal base, as  $\phi_k$ , it is possible to calculate the modes that will be used in the equation of motion for the two connected substructures. The general connectivity matrix is obtained using some auxiliary variables,

$$A = (\delta_{fc}^a + \delta_{fc}^b)^{-1} \quad (3)$$

where  $a$  and  $b$  are respectively the substructures  $a$  and  $b$ .

The matrix  $\delta_{fc}$  is the portion of residual flexibility modes relative to interface among the two substructures connected. A global equation of motion taking into account the two connected substructures it can be synthesized for,

$$M\ddot{p} + Kp = 0 \quad (4)$$

where,

$$q = Sp \quad S = \begin{bmatrix} -\hat{A} \phi_{kc}^a & \hat{A} \phi_{kc}^b \\ \hat{A} \phi_{klc}^a & -\hat{A} \phi_{kc}^b \\ I_{kk}^a & 0 \\ 0 & I_{kk}^b \end{bmatrix} \quad (5)$$

$$M = \begin{bmatrix} I_{kk}^a + \phi_{kc}^{a^t} V \phi_{kc}^a & -\phi_{kc}^{a^t} V \phi_{kc}^b \\ -\phi_{kc}^{b^t} V \phi_{kc}^a & I_{kk}^b + \phi_{kc}^{b^t} V \phi_{kc}^b \end{bmatrix} \quad K = \begin{bmatrix} \Lambda_{kk}^a + \phi_{kc}^{a^t} A \phi_{kc}^a & -\phi_{kc}^{a^t} A \phi_{kc}^b \\ -\phi_{kc}^{b^t} A \phi_{kc}^a & \Lambda_{kk}^b + \phi_{kc}^{b^t} A \phi_{kc}^b \end{bmatrix} \quad (6)$$

$$V = A^t (\beta_{ff}^a + \beta_{ff}^b) A \quad \beta_{ff} = \theta_{dc} (\Lambda_{dd}^{-1})^2 \theta_{dc}^t \quad (7)$$

Solving the reduced eigenproblem, equation (4), they are obtained eigenvalues and eigenvectors ( $\Sigma$ ) representative of the problem in the kept (p) modal coordinates. To come back to the system original modal base use a inverse operation,

$$\xi = E S \Sigma \quad (8)$$

where:

$$S = \begin{bmatrix} -A\phi_{kc}^a & A\phi_{kc}^b \\ A\phi_{kc}^a & -A\phi_{kc}^b \\ I_{kk}^a & 0 \\ 0 & I_{kk}^b \end{bmatrix} \quad E = \begin{bmatrix} \delta_{fi}^a & 0 & \phi_{ki}^a & 0 \\ \delta_{fc}^a & 0 & \phi_{kc}^a & 0 \\ 0 & \delta_{fi}^b & 0 & \phi_{ki}^b \\ 0 & \delta_{fc}^b & 0 & \phi_{kc}^b \end{bmatrix} \quad (9)$$

(S) and (E) they are the restriction matrices and original modal bases of substructures, respectively. The procedure of modal synthesis using two interconnected components generates equations of easy computational implementation being always used two substructures mutually connected. The first two connected substructures will be considered, in a next stage, as a new and only substructure that is connected to at a third. Thus, the substructures is going being connected, one to one, until the assembly of the global structure.

### 2.1. Modes automatic choice criteria

In the processes of modal synthesis that use the modal superset of residual flexibility, the user defines which modes will be removed from the modal base. This choice will be used to define the residual flexibility modes that will be used to improve the modal base of each substructure. Then, any modes significant in the identification of the original system can be removed same keeping an enough number of modes in the base. This fact is also observed in most of the methods of modal synthesis. In the method of automatic elimination proposed by Cleudmar, A. A. (1998), was observed that when the level of energy of the boundary of the substructures is small, more precise results is obtained for the synthesized eigenvalues and eigenvectors. For each substructure as smaller the energy of the boundary coordinates relatively to the energy of the internal coordinates minor would be the influence of this mode in the synthesis of the complete system. This supposition is based in the fact that the internal portions of energy of the selected modes are the main responsible for the motion of vibration of the complete system. The relative portions to the boundary of the substructures will be naturally subject to the conditions imposed by the joining. Then, the comparison between the contour and the internal portions of the substructures supplies a quality index among the modes of a certain substructure. This supposition is the base of the approach of automatic elimination of modes, that is to say, if for a certain mode the joining is very significant in relation to the joint internals, a great probability exists of obtaining a low convergence in the results ends of the synthesis.

### 3. Estimated Physical Parameters – Chen Method

Considering a structure with damping, the equation of motions can be written for,

$$\ddot{x}^C(t) + C\dot{x}^C(t) + Kx^C(t) = f(t) \quad (10)$$

where,  $M$ ,  $K$  and  $C$  are the mass, stiffness and damping matrices, respectively, of order  $n \times n$ . For harmonic force excited, the equation (10) can be expressed as,

$$(-w^2M + K)x^C(w) + iwCx^C(w) = f(w) \quad (11)$$

The term inside of the bracket it represents the inverse of normal FRF. The equation (11) it can be written as,

$$[H^N(w)]^{-1} x^C(w) + iwCx^C(w) = f(w) \quad (12)$$

where  $H^N(w)$  is the matrix generated FRF of the normal modes. Pre-multiplying the equation (12) for  $H^N(w)$ , it is had,

$$x^C(w) + iG(w)x^C(w) = H^N(w)f(w) \quad (13)$$

where,

$$G(w) = wH^N(w)C \quad (14)$$

$G(w)$  it is called transformation matrix. It is noticed that  $G(w)$  is a real matrix. The equation (13) it can be expressed as,

$$x^C(w) = [I + iG(w)]^{-1} H^N(w)f(w) \quad (15)$$

where ( $I$ ) is an order  $n \times n$  identity. The frequency response can also be represented as,

$$x^C(w) = H^C(w)f(w) \quad (16)$$

where  $H^C(w)$  is the complex FRF. Comparing Eqs. (15) and (16), the relationship among FRFs for complex and normal modes is given for,

$$H^N(w) = [I + iG(w)]H^C(w) \quad (17)$$

It is noticed that  $H^C(w)$  is a square matrix since it was synthesized by the identification of the complex modes. Separating  $H^C(w)$  in the real and imaginary parts, and expanding the resulting equation obtained,

$$H^N(w) = [H_R^C(w) - G(w)H_I^C(w)] + i[G(w)H_R^C(w) + H_I^C(w)] \quad (18)$$

If the left side of the equation (18) it is a real matrix, then the imaginary part on the right side should be the same to zero for all the frequencies and the transformation matrix can be solved in terms of the matrices  $H_R^C(w)$  and  $H_I^C(w)$ . In another words,

$$G(w) = -H_I^C(w)[H_R^C(w)]^{-1} \quad (19)$$

Substituting (19) in (18) it is find,

$$H^N(w) = H_R^C(w) - G(w)H_I^C(w) \quad (20)$$

The transformation matrix  $G(w)$  and normal matrix  $H^N(w)$  can be calculated respectively by the equations (19) and (20). Once that are available the matrices  $G(w)$  e  $H^N(w)$ , the damping matrix can be calculated of the equation (14).

### 3.1. Damping Matrix

For a case free from noise, an exact solution for the damping matrix can be obtained directly of the equation (14) for,

$$C = \frac{1}{w_j} [H^N(w_j)]^{-1} G(w) \quad (21)$$

where  $w_j$  is a chosen frequency. In the practice, FRFs is contaminate with noise whose intensity depends on the experimental conditions. In this case a square minimum method is used to obtain the damping matrix. Of the equation (14) it is obtained,

$$wh_i^N(w)C = g_i(w) \quad (22)$$

where  $h_i^N(w)$  and  $g_i(w)$  they are the vectors lines of  $H^N(w)$  and  $G(w)$ , respectively. The equation (22) can be written as,

$$VC = Q \quad (23)$$

where  $V$  and  $Q$  they are given respectively for,

$$V = \begin{bmatrix} w_1 h_i^N(w_1) \\ w_2 h_i^N(w_2) \\ \dots \\ w_m h_i^N(w_m) \end{bmatrix}_{(m \times n)} \quad Q = \begin{bmatrix} g_i(w_1) \\ g_i(w_2) \\ \dots \\ g_i(w_m) \end{bmatrix}_{(m \times n)} \quad (24)$$

Being  $C$  a symmetrical matrix, it is defined a parametric vector,  $\bar{c}$ , of the lower matrix triangular of the  $C$  as:

$$\bar{c} = [c_{11} c_{21} c_{22} c_{11} \dots c_{ii} c_{n1} \dots c_{nn}]_{(1 \times \frac{n(n+1)}{2})}^T \quad (25)$$

where  $c_{ij}$  is the  $(i,j)$  element of the damping matrix  $C$ . Re-obtaining the matrices  $V$  and  $Q$  adequately, in agreement with the equation (25), the real equation can be written as,

$$\bar{V} \bar{c} = \bar{q} \quad (26)$$

where  $\bar{V}$  and  $\bar{q}$  they are formed of the matrices  $V$  and  $Q$ , respectively. It is noticed that the dimension of  $\bar{V}$  é  $mn$  by  $n(n+1)/2$  and  $\bar{q}$  is  $mn$  by 1. The equation (26) it can be solved by the square minimum method of the, in another words,

$$\bar{V}^T \bar{V} \bar{c} = \bar{V}^T \bar{q} \quad (27)$$

Of the solution of the vector  $\bar{c}$  is obtained the damping matrix  $C$ . It is noticed that the reduction is obtained independently of the mass and stiffness.

### 3.2. Mass and Stiffness Matrices

For an undamping system, the equation of motion can be written as,

$$(-w^2 M + K)x^N(w) = f(w) \quad (28)$$

The relationship among the matrices  $M$ ,  $K$  and  $H^N(w)$  it is given for,

$$(-w^2 M + K)H^N(w) = I \quad (29)$$

where  $H^N(w)$  is calculated of the equation (20). considering the symmetry of  $H^N(w)$  e taking yours  $i$ -esima line, it is obtained,

$$MA^T + KB^T = E^T \quad (30)$$

where,

$$A^T = \begin{bmatrix} w_1^2 h_i^N(w_1) \\ w_2^2 h_i^N(w_2) \\ \dots \\ w_m^2 h_i^N(w_m) \end{bmatrix}_{(m \times n)}^T \quad B^T = \begin{bmatrix} h_i^N(w_1) \\ h_i^N(w_2) \\ \dots \\ h_i^N(w_m) \end{bmatrix}_{(m \times n)}^T \quad (31)$$

and  $E^T$  is the identity matrix. Taking it transposed of equation (30) and considering the symmetry of  $M$  and  $K$ , it is obtained,

$$\begin{bmatrix} A & B \\ & K \end{bmatrix} \begin{bmatrix} M \\ & K \end{bmatrix} = E \quad ; \quad (\overline{R^T R}) \overline{S} = \overline{R^T E} \quad (32)$$

In a similar way, doing  $R = \begin{bmatrix} A & B \\ & K \end{bmatrix}$  and  $S = \begin{bmatrix} M \\ & K \end{bmatrix}$ , the equations (32) can be solved by the square minimum method, where  $\overline{R}$ ,  $\overline{S}$  and  $\overline{E}$  they are formed of the matrices  $R$ ,  $S$  and  $E$ , respectively.

#### 4. Experimental Model

The figure 2 shows one of the substructures of analyzed system where were obtained the experimental FRFs for evaluation of the Chen method. The substructure is formed by three parallel plates of aluminum and connected by sheets of steel of 1 mm of thickness. Each connection is made by a group of 4 sheets that are fixed to the plates through screws. The group is assembly through a base fixed the inertial table. The plates can be approximate for lumped masses,  $M_1$ ,  $M_2$  and  $M_3$ , with stiffness coefficients,  $K_1$ ,  $K_2$  and  $K_3$ , constituted by the combination of the stiffness of the 4 sheets that make the respective connections between the plates and the fixed support. The substructure has a damped coupled between the mass  $M_1$  and the fixed support, as shown in the figures 2 and 3.

The assembly of two symmetrical substructures formed by the plates constitutes the complete structure. FRFs of the two substructures was obtained of the same physical substructure, using the triangular lower matrix for a substructure and the triangular upper matrix to another one. The results of the experimental synthesis were compared using a model of lumped mass problem available at Matlab environment.

The figure 3 shows the schematic experimental apparatus used to determine experimental FRFs. In this system each plate was excited independently by a pulse using an impact hammer and the signals were captured through an accelerometer coupled to the plates (SISO). The signs were conditioned and analyzed to a sign processor SD380. FRFs extracted was used in the methodology proposal. The table 1 presents the estimated values of the mass matrix and the relative error in relation to the true matrix. It is observed that the maximum relative error is smaller at 4%.



Figure 2. Experimental model of the substructures analysis.

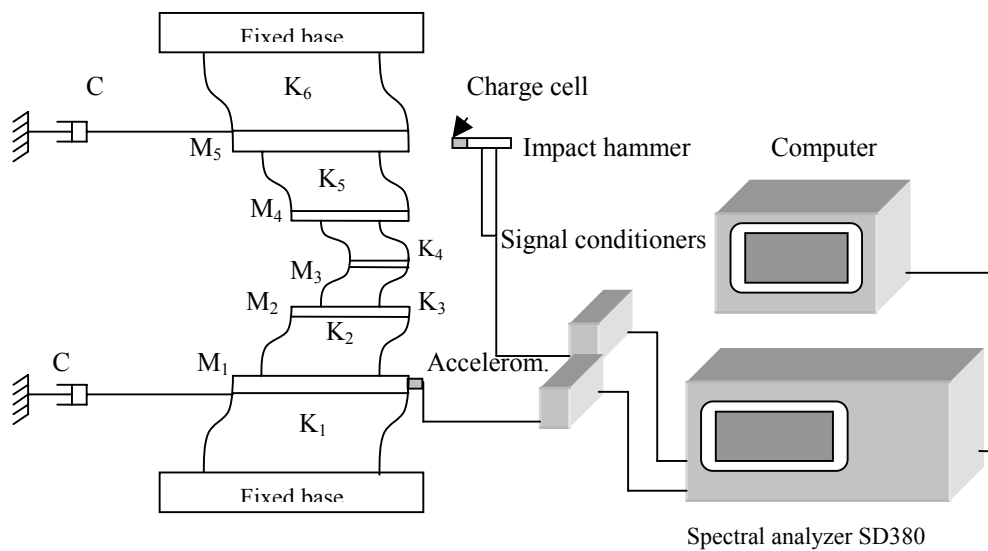

Figure 3. Experimental scheme for obtained of the FRFs.

Table 1. Exact and identified values for mass of the experimental model using Chen method.

	Exact values (Kg)			Identified Values (Kg)			Relative error (%)		
Substructure 1	<b>3.300</b>	0	0	<b>3.185</b>	-0.009	-0.003	<b>3.471</b>	-	-
	0	<b>2.223</b>	0	-0.009	<b>2.140</b>	0.000	-	<b>3.743</b>	-
	0	0	<b>0.929</b>	-0.003	0.000	<b>0.960</b>	-	-	<b>3.367</b>
Substructure 2	<b>0.929</b>	0	0	<b>0.937</b>	-0.006	0.014	<b>0.849</b>	-	-
	0	<b>2.223</b>	0	-0.006	<b>2.159</b>	0.012	-	<b>2.858</b>	-
	0	0	<b>3.300</b>	0.014	0.012	<b>3.257</b>	-	-	<b>1.294</b>

At the identification of the system matrices, it was verified that the damping is quite difficult of being identified with precision from data with noise. This result is, in most of the cases, due to order of damping coefficients that are much smaller than the stiffness coefficients. In another methods of estimated of the physical parameters, in general, the mass, the stiffness and the damping are simultaneously identified, using one only equation. In this work this situation doesn't happen and the identified damping parameters are more accurate, once, the damping matrix is esteemed independently of the mass matrix and stiffness. With relationship to the general objective of the proposal this improvement has not been meaning, once, the main objective these work is the estimate of the mass matrix of system.

The normalized modal bases of each substructure were obtained using the physical matrices M, C e K esteemed by the method of Chen. The total number of modes of each substructure is 3 and for the complete structure is 5. The number of boundary coordinates among the substructures is 1. Therefore there is just one mode of residual flexibility that will compose the modal superset of residual flexibility more 2 flexible modes for each substructure.

In the best condition 2 modes are kept for each substructure, that results in 4 modes synthesized for the complete structure. Using CEAM, Approach of Automatic Elimination of Modes, Cleudmar A. A. (1998), it is verified that the 2nd mode is removed, being maintained the 1st and the 3rd modes. In the worst condition one mode is just maintained for each substructure while two are removed. In this case, using CEAM, the 1st mode is maintained in the two substructures, being removed the 2nd and the 3rd mode. Thus, they are just synthesized 2 modes of the complete structure

The Tabs (2) and (3) compare the dynamic parameters synthesized to those obtained by the lumped mass model. To know the relationship among modes of the synthesized structure and of the analytic model was calculated the MAC number, among the eigenvectors of these two models, D. J. Ewins (1984). For each synthesized mode, 5 values of MAC were calculated, corresponding to the modes obtained analytically by the lumped mass model of the complete structure. It was calculated, also, the relative error among the frequencies. Observing the graphs of MAC, figures 4 and 5, can be discriminated the modes of the structure synthesized with the modes of the structure modeled by lumped mass method.

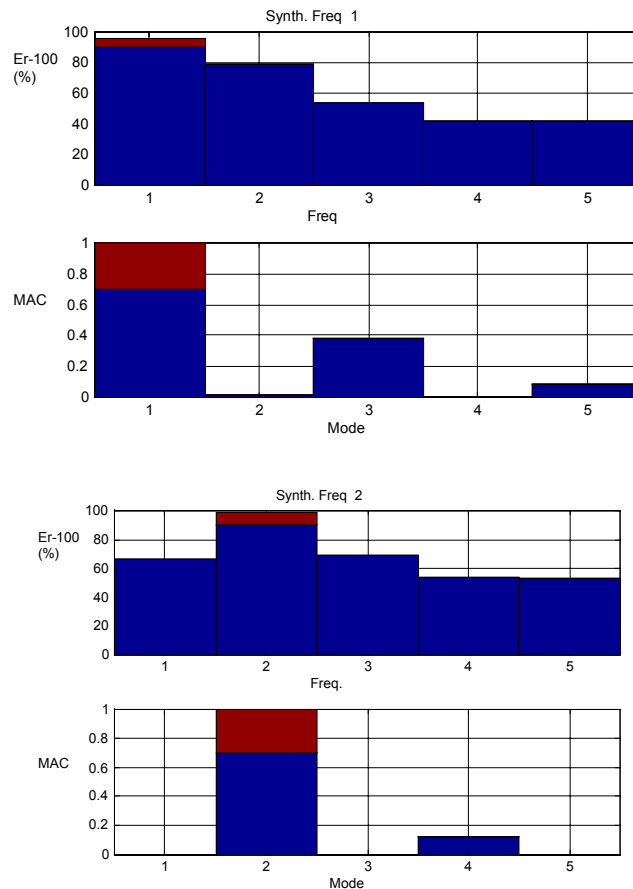

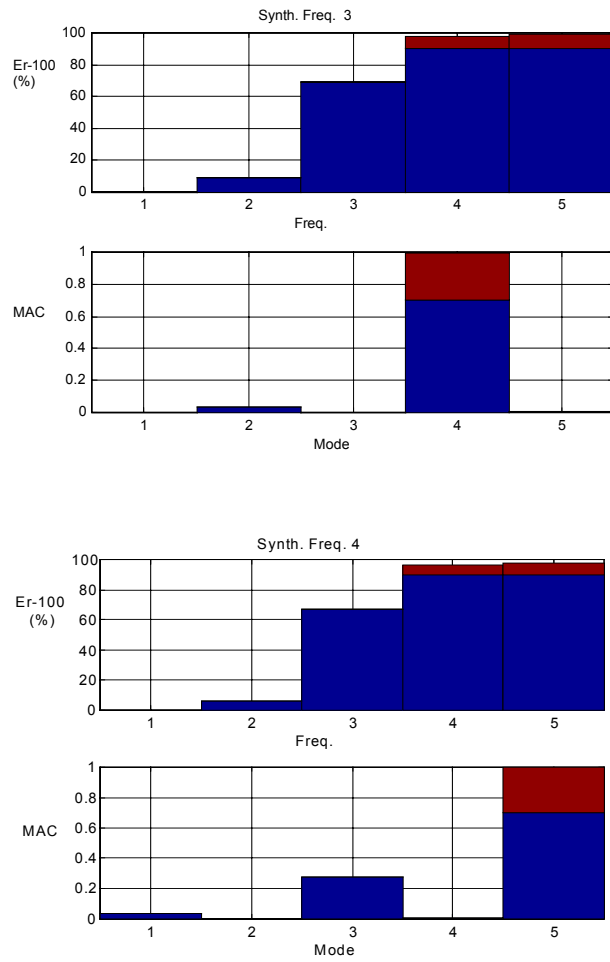

Figure 4. Relationship between modal bases synthesized and Original using 2 modes kept for each substructure.

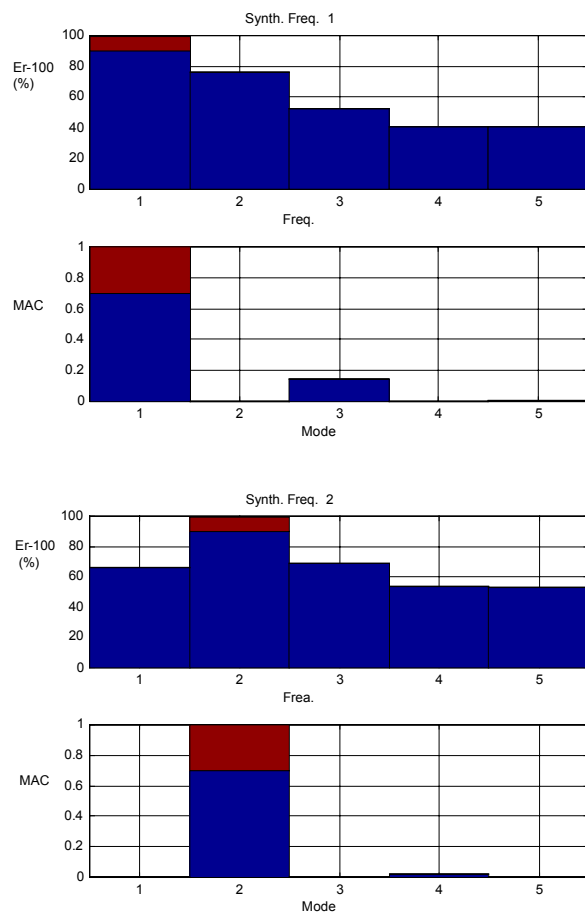

Figure 5. Relationship between modal bases synthesized and Original using 1 modes kept for each substructure.



Table 2. Relationship between modal bases synthesized and Original using 2 modes kept for each substructure.

Mode	MAC	Syntheses. Freq. (Hz)	Original Freq. (Hz)	Relative Error (%)
1	1.00	8.87	8.80	0.90
2	1.00	11.73	11.63	0.86
3	-	-	16.97	-
4	0.99	22.22	21.73	2.25
5	0.99	22.52	22.04	2.14

Table 3. Relationship between modal bases synthesized and Original using 1 modes kept for each substructure.

Mode	MAC	Syntheses. Freq. (Hz)	Original Freq. (Hz)	Relative Error (%)
1	1.00	8.87	8.80	0.90
2	1.00	11.74	11.63	0.93
3	-	-	16.97	-
4	-	-	21.73	-
5	-	-	22.04	-

## 5. Conclusions

The results of identification of the mass matrix of substructures using the Chen method showed that the maximum relative error is smaller at 4%. The mass matrix esteemed was used in the modal base normalization of the substructures, and then it was used in the technique of modal synthesis SMFR. The results presented in the tests confirm an improvement in the normalization process. It was observed that the error maximum of the synthesized frequencies was of 2% with a MAC index near of the unit. This effect was observed even in the worst condition (One mode kept for each substructure). So that a larger effectiveness of the method is checked it is necessary the use of a more complex experimental model.

## 6. References

- Chen, S. Y., Ju, M. S., e Tsuei, Y. G., 1996, "Estimation of Mass, Stiffness and Damping Matrices from Frequency Response Functions," *ASME Journal of Vibration and Acoustics*, V.118, pp 78-82, Janeiro.
- Cleudmar, A. A., 1998, "Modelagem de Sistemas Dinâmicos Através da Síntese Modal de Componentes," Tese de Doutorado, Faculdade de Engenharia Mecânica, Universidade Estadual de Campinas, 158 p., Campinas.
- Cleudmar, A. A., Jacomine, L., Consentino R. J., 2001, "Avaliação da técnica de normalização por massa modal unitária utilizada na síntese modal experimental", Congresso Brasileiro de Engenharia Mecânica, XVI COBEM, Novembro, Uberlândia, MG.
- Craig Jr., R. R., Kurdila, A. J., e Kim H. M., 1987, "State-Space Formulation of Multi-Shaker Modal Analysis," *Proceedings of 5<sup>th</sup> International Modal Analysis Conference*, London, England, pp. 1069-1077.
- Ewins D. J. 1984, "Modal Testing: Theory e Practice", Research Studies Ltd., McGraw-Hill.
- Richardson M. H., 1977, "Derivation of Mass, Stiffness, And Damping Parameters from Experimental Modal Data", Hewlett Packard Company, Santa Clara Div., pp. 1-6.
- Richardson M. H., 2000, "Modal Mass, Stiffness, And Damping" Vibrant Technology, Inc., Jamestown, CA, pp.1-5.

## 7. Copyright Notice

The author is the only responsible for the printed material included in his paper.