



## WIRELESS DISTRIBUTED CONTROL FOR POWER LINE INSPECTION ROBOT

**Danilo de Souza Miguel**  
**Marcio Marques Calif**  
**Alexandre Coletto**  
**Gabriel Pereira das Neves**  
**Celso T. Matsumura**  
**André R. Hirakawa**  
**Oswaldo Horikawa**

Escola Politécnica - University of São Paulo (EPUSP)  
Av. Prof. Mello Moraes, 2231, 05508-030, São Paulo, SP, BRAZIL  
[arhiraka@usp.br](mailto:arhiraka@usp.br)

**José Francisco Resende da Silva**

Elektro Electricity and Services S.A.  
Rua Ary Antenor de Souza, 321, 13053024, Campinas, BRAZIL  
[jose.resende@elektro.com.br](mailto:jose.resende@elektro.com.br)

**Abstract.** *Inspection of overhead power lines is a big challenge for all utility company due to the lack of tools, devices and resources available. Several works were presented to solve such problem and most of them are based on the use of Unmanned Aerial Vehicle (UAV) that carries appropriate inspection devices. However, those solutions present several problems such as difficult in operation, high cost and low precision. On this context, EPUSP and Elektro are conducting a research and development project of a Power Line Inspection Robot that travels over the distribution power line. The proposed robot has a lightweight and insulated "Y" body frame with three-drive wheel on each hub. The description of robot's mechanism is presented in another paper. Besides the innovative robot solution, controlling and driven the robot is also a big challenge due to the work on an environment with high voltage (13.8 kV). Therefore, this paper presents the proposal of a wireless distributed control system for controlling inspection robot wheels. Each wheel has independent power source, power driver, motor and a controller that implements local closed loop control scheme. A main controller, that implements a navigation routine based on image processing and GPS information sends the navigation references to each wheel by a XBee wireless communication channel. Actual controller implementation was done using ARM-8 platform for main controller and Arduino platform for each wheel. This paper also presents the description of the controller structure and preliminary test results.*

**Keywords:** *robot, motor control, wireless control, inspection task, power line.*

### 1. INTRODUCTION

Inspection of distribution power lines is a big challenge for utilities due to size of the power network and the diversity of equipments, devices and work conditions. In such environment there are components like: insulators, jumpers, cables, crossarms, poles, telecommunication facilities and the surrounding vegetation. Nowadays, the inspection process is done by electricians using binoculars or thermo-camera for identifying hot spots and other faults. Thus, the inspection procedure is time consuming, requires many resources, and, unfortunately, presents low accuracy in its results.

With the increasing size and complexity of the energy distribution system, the automated inspection has been proposed, but most of them are focused on transmission power lines, in which the structure and devices used are well standardized. Most of proposals mention flying robots or climbing robots. Perhaps the use of flying robots has been inspired by the current use of helicopters for inspection of transmission power lines. Recent researches on flying robots deal with autonomous flying robots, i.e., those that are not remote controlled by human operators. In such case, the robot should follow a power line while keeping a safe distance. The navigation of the robot can be done through computer vision, as in Campoy *et al.*, 2001 that uses stereo vision.

Flying robots have the advantage of transposition any kind of obstacle. However, flying robots have problems related to the automation of power line tracking, failures on visual inspection as well as the needed of keeping a safety distance from the power line. In some cases, vegetations can obstruct the vision of flying robot.

One alternative to flying robots is the climbing robot that moves suspended on the transmission line. These kinds of robots require complex mechanisms for performing transposition of obstacles. A proposal of climbing robot is presented by Tavares and Sequeira (2004), in which the structure is composed by a central body, two lateral arms and a

Miguel, D. S., Calif, M. M., Coletto A., Neves, G. P., Matsumura C. T., Hirakawa, A. R., Horikawa, O., da Silva, J. F. R.  
Wireless Distributed Control for Power Line Inspection Robot

main arm. The main arm is used for robot stabilization when overtaking obstacles. Claws at the hub can grab the line and move the structure like a worm.

Otherwise, distribution power lines have diversity of implementations and conditions, which difficult the use of any kind of automated devices or robots for inspection.

The design of the robot structure for inspection must take in account the functional specification that comes from requirements and constraints of usual distribution line, which is aerial and has a primary network voltage of 13.8 kV (Phase to Ground) on each of  $3\phi$ s.

The cable of the primary line is constructed by copper or aluminum and are fixed to the crossarms through ceramic insulators. Crossarms, made by wood, steel, fiberglass or polymeric materials, are bolted to poles (Elektro, 2008). Figure 1 shows a typical distribution line setup.

The poles are placed each 80m of distance and are usually made with concrete or H wood (Short, 2004).

The distances between cables of the primary network may vary between 600mm to 1200mm. In some cases, those distances are not homogeneous and the cable at the middle is closer to one of the external cable.

When considering a robot traveling along the distribution line, some obstacles should be considered. The most usual obstacles in the distribution network are cables, insulators, cross arms and jumpers.

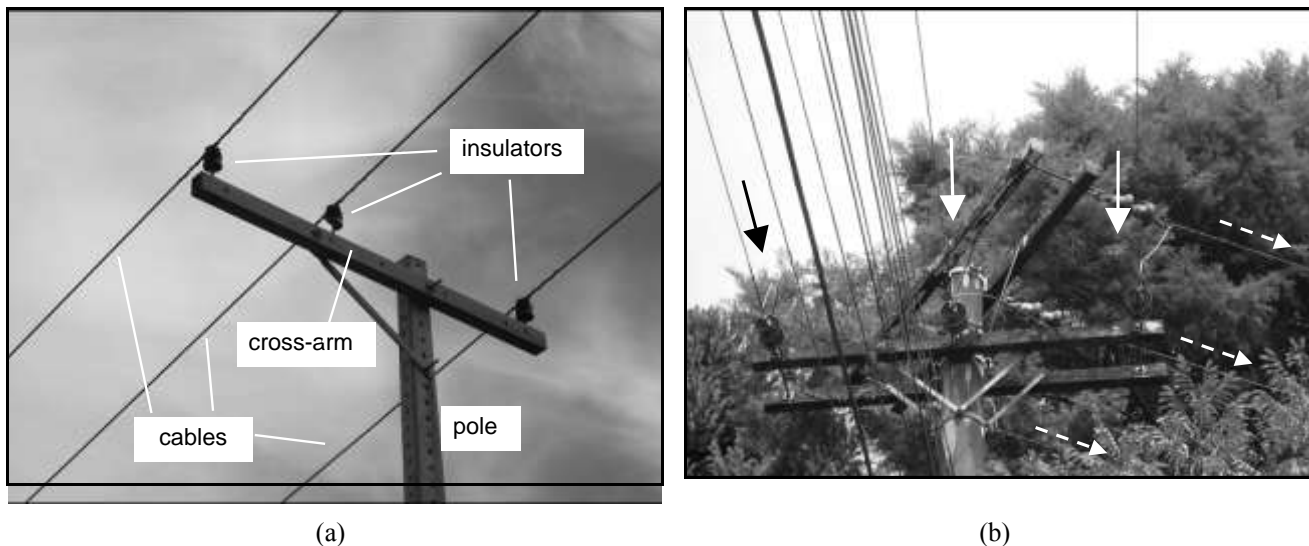

Figure 1. Usual electrical distribution lines. (a) Simple path, (b) Complex path.

## 2. INSPECTION ROBOT

On the challenging inspection task of distribution power lines scenario, a novel robot structure is proposed by EPUSP and Elektro Research and Developing Team. Figure 3 shows the outline of the robot proposed that can travel over the three cables of the primary distribution lines. The mechanical design is suitable to specification and needs mentioned above. The use of three supporting points has the advantage of keeping the center of gravity internally of the tripod contact and the flexible body frame can self adjust wheel distance in accordance to the distance between cables. Moreover, each wheel is designed to overpass most of obstacles in the distribution line. The only limitation is that the height difference between cables cannot be greater than the height of the wheels.

The robot body frame is constructed by glass-reinforced plastic (fiberglass) due to its mechanical and electrical properties for the application, which have higher dielectric constant and lightweight with strength.

The robot wheels are designed having in minded the obstacles to be overpass and have double conical geometry to assure, in all situations, the contact with wires, insulators and jumpers. In addition, this geometry allows self-guidance of the robot by taking the advantage of the weight of the robot that always enforces wheel be aligned to the cables and the cable fitted in the channel of cone centre (Figure 4).

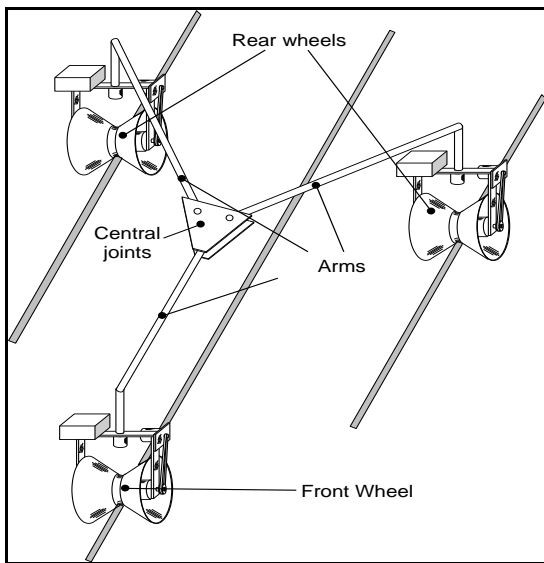

Figure 3. Inspection Robot

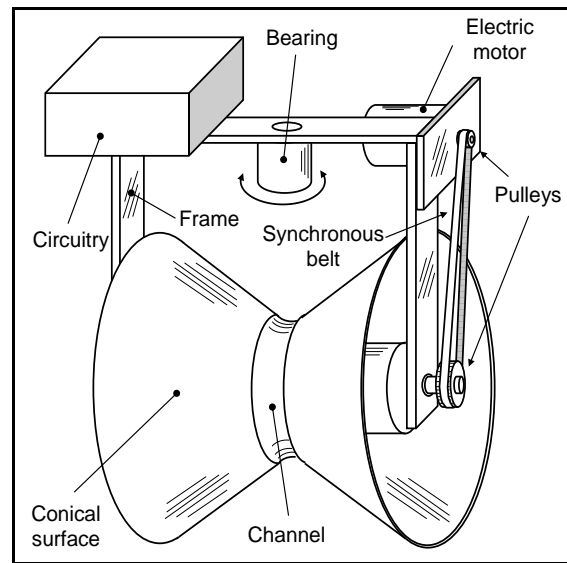

Figure 4. Details of the wheel

Each of the three wheels of the robot must be controlled independently due to the forces and velocity required on each wheel in accordance to the variation of distribution lines geometry. Indeed, slipping between wheel and cables, or obstacles, demands also an independent controlling. Therefore, each wheel cluster is designed to have completely and independent operation.

In the same way as body frame construction, insulated and lightweight material is used in the wheel and its frame. Rubber belt is used to force transmission from DC motor to wheel.

Laboratory tests were conducted on the robot to assure insulation rate up to 3 times of the primary distribution line voltage (13.8 kV).

### 3. DISTRIBUTED WHEEL CONTROLLING

The inspection robot was designed to attend functional specification of distribution line working environment constraints, and so, it has flexible and self adaptive body frame. Indeed, it must have distributed and independent controlling of each actuator due to the movement constraints and hazardous high voltage cables, on which, the robot moves on.

From the electrical theory, a wire, or cable, when traversed by an electrical current, generates a magnetic field in your surroundings according to the circuital Ampere law. This field is proportional to the current in the wire, and in distribution power lines, the current can reach 200A in peak time, generating a field capable of serious damage in the low power controlling circuitry and data transmitted by copper cable. Also, two conductor cables, when submitted to electrical current, generate a mutual attraction force (currents in opposite directions) or repulsion (currents in same directions), according to the second elemental law of Laplace. The force is proportional to the currents which the cables are submitted and can be a source of instability to the robot.

As the robot will work in such kind of environment, use of cables and large conducting material must be avoided and the electric controlling circuitry must be designed considering such constraints. Figure 5 shows the electric controlling diagram for the robot.

In the figure, each robot wheel was designed to have self controlling capability and management of movement parameters.

802.11 wireless communication standard is used to transmit overall inspection data and images from the robot to Base Controller and to transmit controlling data from Base Controller to the robot itself. The Base Controller is implemented in a portable Personal Computer and is carried out by the supervisory electrician.

Main Robot Controller is in charge of managing robot behavior and inspection data transmission. Main Robot Controller and Main Wheel Controller boards are in the same board box case and, so that, the movement parameters for the Main Wheel is transmitted by wire using I2C standard.

Each of side wheels (Left and Right) exchange data with Main Controller by 802.15.4 (Xbee) wireless communication interfaces.

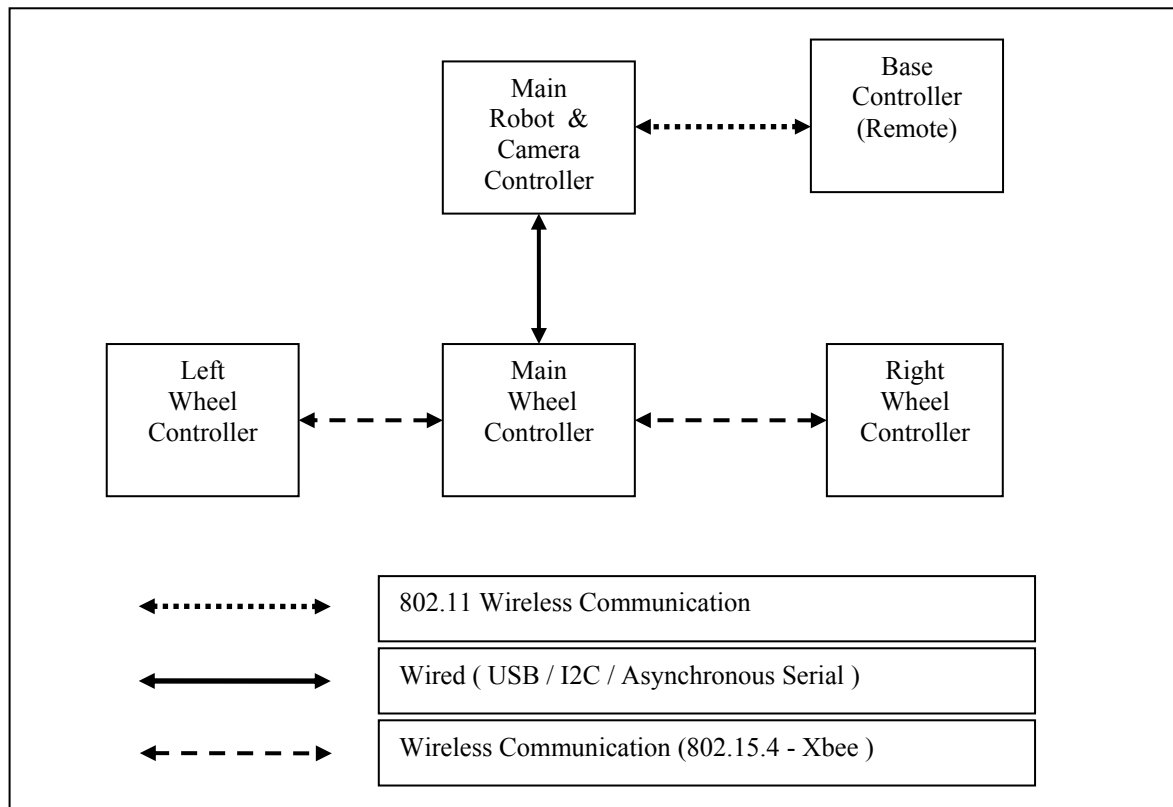

Figure 5. Electric Controlling Diagram

### 3.1 Hardware Description

The distributed control system for the inspection robot was implemented by the use of three modules that has own resources of communication, processing and movement.

The Main Wheel Controller is based on the ARDUINO MEGA platform and by ARDUINO UNO in each side wheel. Each wheel controller has a TB6612FNG Driver that controls the direction of rotation of the motor, the rotation speed (PWM up to 100kHz) and drives the power to DC motor. The Driver IC has two logical signal inputs that allow four different operation modes: clockwise rotation, counter-clockwise rotation, short brake, and stop mode. Furthermore, it has an input signal for standby mode and two PWM input signals, each one for each motor. The ARDUINO's PWM pins are used for defining a value between 0 and 255, which is proportional to the TTL rectangular wave pulse with 50 Hz of frequency.

In addition to distribution control system, there is an embedded processing platform (Devkit) that receives images of distribution power line captured from High Definition cameras. After image processing, the platform sends the movement commands to the ARDUINO MEGA to proceed actual movement of the three wheels of the robot.

### 3.2 Control Scheme

Until now, all tests were conducted considering an open-loop control scheme, which means that references were generated in the Main Controller and sent (by Xbee) to three wheel drives without any feedback. The Main Controller calculates the direction and the velocity (each 100 ms) for each wheel based on the distance to be travelled that comes from image processing feedback.

However, all hardware and circuitry required for implementing a closed-loop control scheme is already included. Each wheel has an encoder sensor and the closed-loop algorithm will run in the ARDUINO UNO platform. Actual position and rotation of each wheel will be feedback to main controller by Xbee channel.

### 3.3 Wheel Module

Each wheel has a module, which includes the battery, DC motor, data transmission/reception interface and controller circuitry. Figure 6 shows actual implementation of a wheel and the controlling circuitry mounted on the wheel frame.



Figure 6. Actual wheel module

In the figure, battery, controlling circuitry, motor driver and wireless communication module are in the black box.

Figure 7 shows detail of the circuitry implemented. The circuitry is composed by a basic stamp of Arduino Uno platform that process data and controlling algorithm and two other board stamps, one for motor power driving (TB6612) and other for wireless communication (Xbee). Both stamps are mounted on a universal circuitry board.

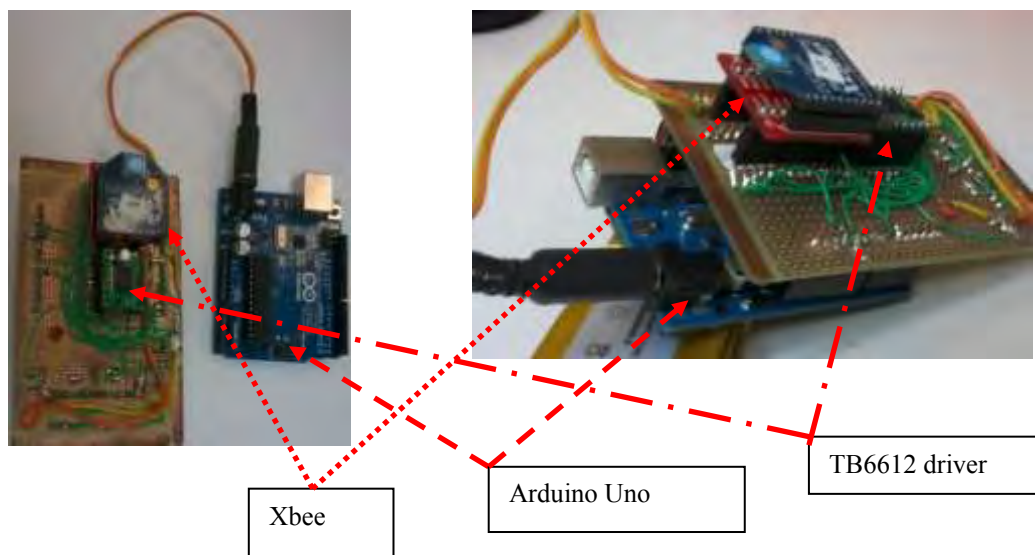

Figure 7. Circuitry detail

### 3.4 Power Source

A battery pack supplies energy for each wheel module, including DC motor. There are several types and technologies of battery available on the market.

Due to the DC motor used, battery for the robot must be lighter and powerful. According the table in Cadex (2013), li-ion polymer battery has energy density (Wh/kg) greater than most other battery types. The main disadvantage of li-

Miguel, D. S., Calif, M. M., Coletto A., Neves, G. P., Matsumura C. T., Hirakawa, A. R., Horikawa, O., da Silva, J. F. R.  
Wireless Distributed Control for Power Line Inspection Robot

ion polymer battery is the higher cost and overcharge tolerance. Therefore, li-ion polymer battery is chosen to minimize the weight and any overcharge and overheat will be avoided to prevent the weakness characteristic of this battery.

The required power from the battery was calculated in accordance to each module features. The MW (Main Wheel Controller) requires more energy than LW (Left Wheel Controller) and RW (Right Wheel Controller).

The power consumption of MW module is calculated from the following composition:

- 1- Arduino Mega (5 UART) - 100 mA (estimated)
- 2- Xbee Serie 1 ( 2 modules) - 100 mA (from data sheet)
- 3- TB6612FNG - 20 mA (digital circuitry)
- 4- DC Motor (12V) (450 mA max, 1.5 A blocked)

From the sum of each circuitry consumption, it is estimated that the maximum current consumption is 670 mA, with peak current of 1720 mA. Therefore, using a battery pack with 3.7 V and 2000 mA·H, the estimated range of working time is around 3 hours.

#### 4. WIRELESS COMMUNICATION FOR DISTRIBUTED CONTROL

The use of wireless communication interfaces for exchanging controlling data in real time systems is another challenging issue. As well known, any wireless communication standard has problems of reliability, availability and determinism of data transmission due to the interferences of the air transmission media. Systems that require high reliability do not use wireless interfaces for controlling, but just for monitoring activities. Besides that, and considering the inspection robot controlling constraints, several wireless interfaces were analyzed for actual application.

Among the communication options studied to perform communication between control systems of the robot, Xbee Series 1 was one that stood out to meet the requirements of the project. The Xbee platform chosen uses 802.15.4 protocol for communication. However, 802.15.4 protocol works in the same frequency range of other protocols, such as the 802.11 protocol, used in home appliances and networking.

Previous works reported interference from 802.11 protocol on 802.14.5 in specific situations, especially when there is occurrence of high level of traffic (Petrova, 2007). Other works performed simulations and measurements on real scenarios (Yanchao, 2011 and Pollin, 2008).

Therefore, it is required detailed analysis of the performance of the two protocols aiming to assure the coexistence of both protocols and the impact of interference from each other. Using a laboratory test platform, several tests were accomplished for analyzing the behavior of 802.15.4 protocol under robot controlling data requirements and considering the coexistence of 802.11.

One of the test scenarios was sending PWM (DC motor control value) signaling by 802.15.4 using the ARDUINO and Xbee setup. In this setup, both robot's side wheels receive the same controlling value.

##### 4.1 Test Results

The most valuable result is the delay observed in the communication between the PC and ARDUINO. The reason is that the message encoded in ASCII, to represent the value of PWM, arrived at ARDUINO and must be decoded. Actually, "Serial.parseInt()" function, which automatically detects the values in a message in ASCII code, is used for decoding, and, due to native function, there is a delay. To minimize such delay, it is proposed the implementation of an own serial function.

Another solution to reduce delay is the use of sending and reception functions, respectively: "Serial.write()" and "Serial.read()". Those functions have the advantage of reading and sending only bytes in binary coding by ARDUINO's serial interface.

The average delay observed in tests was around 3 ms for sending byte long messages. Data packet can be sent up to 32 bytes of size. In this case, the delay observed was around 100 us, which means that the optimum size of data transmission is the maximum size of individual packet, i.e., 32 bytes.

Second test scenario considered performance evaluation of simultaneous communication between Xbees implemented on ARDUINO MEGA and two ARDUINO UNO platforms as shown in Figure 8. In the figure, ARDUINO MEGA board is in the middle and both ARDUINO UNO are in the sides.

Test results shown that performance behavior are similar to previous communication tests, which means, there is a delay between transmitted messages.

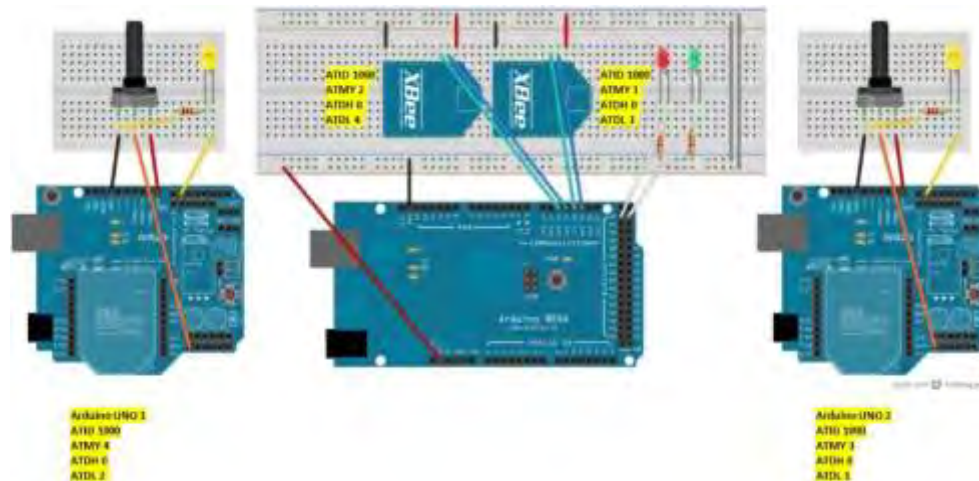

Figure 8. Wireless Communication test setup

One important evaluation criteria on the Xbee channel is the Jitter and Packet Loss due to their interference on robot control algorithm. Besides that, communication experiments were conducted for evaluating such parameters in scenarios where Xbee node numbers were changed. Figure 9 shows test results to Jitter and Packet Loss for scenarios with 2 and 4 Xbee nodes.

In the same way as previous, tests concerning the interference between 802.11 (WiFi) and 802.15.4 (Xbee) were done and actual bandwidths were measured for both WiFi and Xbee, as shown in Figure 10. As expected, bandwidth of Xbee is reduced in accordance to increasing of WiFi usage.

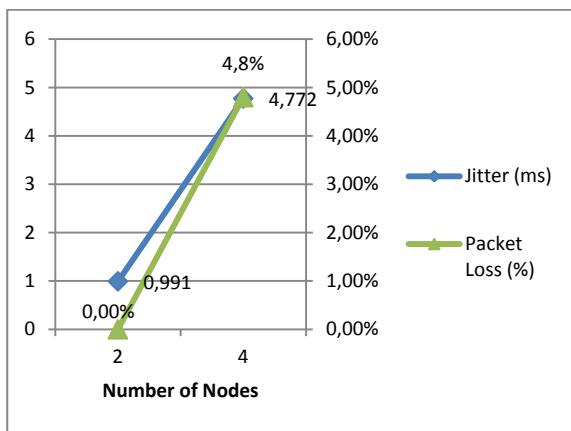

Figure 9. Jitter and Packet Loss

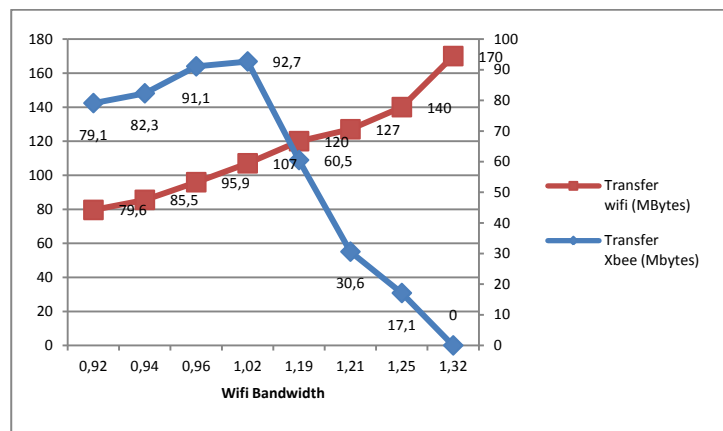

Figure 10. Xbee/WiFi Bandwidth

## 5. CONCLUSIONS

This work presented the proposal of a distributed control structure for an inspection robot that works on distribution power lines. Considering the constraints that come from the working environment, a controlling system was designed and implemented adopting autonomous and modular subsystem with independent resources of power, processing, driving the wheel and communication. In such structure, communication capability is a key issue for implementing any control algorithm. Besides that, Xbee data communication standard was chosen and several tests were conducted for its evaluation.

Test results with Xbee platform shown that performance behavior is suitable for robot controlling application. There is a delay around 3 ms for each transmitting packets between ARDUINOs. Jitter and Packet Loss in data transmission were evaluated on a platform scenario constructed by actual application constraints, and as results, it was observed an acceptable value for controlling proposal.

In addition, tests with different distances between nodes were conducted for evaluating the transmission data rate and packet loss and it was verified that there is no interference of the distance in the Xbee transmission until 5 m of distance.

Miguel, D. S., Calif, M. M., Coletto A., Neves, G. P., Matsumura C. T., Hirakawa, A. R., Horikawa, O., da Silva, J. F. R.  
Wireless Distributed Control for Power Line Inspection Robot

From the positive test results obtained, it can be concluded that the proposed distributed controlling structure is suitable for inspection robot.

The robot, including all subsystems, was submitted to electrical and insulation conformance test in a specialized laboratory and it was approved to work in a real distribution power line.

Future works include implementing the closed-loop control algorithm for all of three wheel driver and conduct field tests.

## 6. ACKNOWLEDGEMENTS

The authors acknowledge support by ANEEL (Brazilian National Electric Energy Agency).

## 7. REFERENCES

- Aracil, R., Pinto, E., Ferre, M., 2002. Robots for live power lines: Maintenance and inspection tasks. IFAC 15th triennial world congress.
- Campos, M. F. M., et al., 2002. A mobile manipulator for installation and removal of aircraft warning spheres on aerial power transmission lines. Proceedings of the 2002 IEEE International Conference on Robotics Automation.
- Campoy, P., et al., 2001. An stereoscopic vision system guiding an autonomous helicopter for overhead power cable inspection. International Workshop RobVis.
- Elektro, 2008. ND01: Materiais e equipamentos para redes aéreas de distribuição de energia elétrica: Padronização. Standard.
- Katrasnik, J. Pernus, F. Likar, B., 2008. New robot for power line inspection. IEEE Conference on Robotics, Automation and Mechatronics.
- Katrasnik, J. Pernus, F. Likar, B., 2010. A survey of mobile robots for distribution power line inspection. IEEE Transactions on power delivery. Vol. 25.
- Learning the basics about batteries - Cadex Electronics Inc, 2013. <[http://batteryuniversity.com/learn/article/whats\\_the\\_best\\_battery](http://batteryuniversity.com/learn/article/whats_the_best_battery)>
- Petrova, M.; Lili Wu.; Mahonen, P.; Riihijarvi, J.; “Interference Measurements on Performance Degradation between Colocated IEEE 802.11g/n and IEEE 802.15.4 Networks”, Networking, 2007. ICN '07. Sixth International Conference on, pp. 93, abril 2007.
- Pollin, S.; Ergen, M.; Timmers, M.; “Distributed cognitive coexistence of 802.15.4 with 802.11”, Cognitive Radio Oriented Wireless Networks and Communications, 2006. 1st International Conference on, pp 1.5, junho 2006.
- Pollin, S. Tan, I.; Hodge, B.; Chun, C.; Bahai, A. “Harmful Coexistence Between 802.15.4 and 802.11: A Measurement-based Study” Cognitive Radio Oriented Wireless Networks and Communications, 2008. CrownCom 2008. 3rd International Conference on, Maio 2008.
- Sangjin Han.; Sungjin Lee.; Sanghoon Lee.; Yeonsoo Kim.; “Coexistence Performance Evaluation of IEEE 802.15.4 Under IEEE 802.11B Interference in Fading Channels”, Personal, Indoor and Mobile Radio Communications, 2007. PIMRC 2007. IEEE 18th International Symposium on, pp.1-5, Setembro 2007.
- Sheppard, Laurel. Thermal Imaging: An Important Maintenance Tool, 2011. <<http://buildipedia.com/aec-pros/facilities-ops-maintenance/thermal-imaging-an-important-maintenance-tool>>.
- Short, T. A. *Electric Power Distribution Handbook*. CRC Press, 2004
- Wu, G. et al, 2010. Navigation strategy for local autonomous obstacles-overcoming based on magnetic density detection for inspection robot of single split high voltage transmission line. Proceedings of the 8th world congress on intelligent control and automation.
- Yanchao Mao Zenghua Zhao; Xin Jia “Understanding the Indoor Interference between IEEE802.15.4 and IEEE 802.11b/g via Measurements” Wireless Communications and Signal Processing (WCSP), 2011 International Conference on, Novembro de 2011

## 8. RESPONSIBILITY NOTICE

The authors are the only responsible for the printed material included in this paper.