



## OBJECT ORIENTED REQUIREMENTS ANALYSIS FOR A FLYWHEEL ENERGY STORAGE SYSTEM

**Rogério Issamu Yamamoto**

**José Reinaldo da Silva**

**Oswaldo Horikawa**

ESCOLA POLITÉCNICA DA UNIVERSIDADE DE SÃO PAULO, SÃO PAULO - SP - Brazil

rogerio.yama@usp.br

reinaldo@usp.br

ohorikaw@usp.br

**Isaias da Silva**

UNIVERSIDADE FEDERAL DE SÃO PAULO, DIADEMA - SP - BRASIL

isaias.sv@uol.com.br

**Abstract:** *A large number of current systems use uninterrupted energy supply, "UPS" (Uninterrupted Power Supply), based on Li-ion batteries or another compound, to store the energy. Although such solution can come out of a direct requirement analysis, the electrochemical batteries have several limitations such as the small numbers of charge and discharge cycles. Besides, chemical batteries can cause environmental damage when discarded improperly. Flywheel energy storage systems are candidates to replace chemical batteries some advantages, which do not show up clearly when a traditional direct analysis of requirements is done (and it is too late to be included later on). This problem can be observed every time we have an engineering design problem called in a close domain, that is, where the domain of the application is very close to the developer's domain. This is due to the lack of a relational analysis of the requirements, for instance, based on objects. In this work we reviewed a small and practical design problem focusing in the choice of the energy supply system but using an object oriented approach based on a system called KAOS (Knowledge Acquisition in Automated Specification), which is capable to provide this relational analysis. We can have a good argument to analyze prospective solutions related to requirements and justify the choice of flywheel systems, in this specific case. Even in this simple problem it is possible to notice the importance of performing a criterial requirements analysis in mechatronic design and how that could avoid some wrong decision-making derived from that.*

**Keywords:** *Flywheel, Requirements engineering, UPS.*

### 1. INTRODUCTION

#### 1.1 Concept of the flywheel

Today, the essential systems that need electric energy to work must be protected against several types of problems, e.g. fail in the electric energy supply chain and voltage oscillations, among others. Thus, in order to overcome these failures, the systems usually use devices that can provide electric energy even when the electric supply is offline or unstable, avoiding a general break of the system (ZANEI, et al. 2007).

Theses backup power supply systems usually use electrochemical batteries to provide electric energy when the main power supply is offline or unstable. However theses batteries have some limitations, such as:

- A limited number of charging and discharging cycle;
- Possibility to result in environmental damage due to inappropriate discard of the device parts;
- Possibility of a fracture of the casing resulting in damage to the user because one of the main battery chemical products are generally acid, or to the environment.

Searching others alternatives to substitute the electrochemical batteries, some researches indicate the electromechanical batteries (POST 2006 and FEDERAL TECHNOLOGY ALERTS 2003). The electromechanical batteries, also known as flywheel energy storage systems or simple flywheels, are devices capable of storing electric energy as rotating kinetic energy. Nevertheless, the main disadvantage of flywheels is associated with its high cost of installation, however the cost is justified by the following advantages:

- (a) Long life cycle, about 20 years while the electrochemical batteries last between 3 and 5 years, because the limited number of charging and discharging cycles;
- (b) Low maintenance cost, due the application of the magnetic bearings, which are frictionless;
- (c) No pollution or sound, because mechanical components are enclosed in a vacuum chamber;
- (d) Higher stability and reliability compared with the electrochemical batteries, since the flywheels do not use any chemical or corrosive products;
- (e) Operation in environments with temperature range between -20°C and 40°C;

(f) Reduced dimension, about 10% or 20% when compared to the electrochemical batteries, with the same load capacity (FEDERAL TECHNOLOGY ALERTS 2003).

The flywheel operating principle is the following: a rotor is activated by an electric motor or by the movement of the main system, such as an electric vehicle. Due to the rotor rotation, the flywheel stores kinetic energy and later on, when the main system needs electric energy, the stored kinetic energy is converted into electric energy, and the motor now works as a generator. The conversion of the kinetic energy to electric energy can be done by two ways. The first one is using permanent magnets in the rotor where a flywheel rotation generates a variation of the magnetic field, which in its turn generates an electric current in the motor coils slowing down the flywheel rotation. The second way is by using a motor-generator assembly, which does not use permanent magnets. In this configuration, the rotation of the flywheel rotor does not generate electric energy, because there is no applied magnetic field. In order to convert the stored kinetic energy of the flywheel it is necessary to provide electric current to the motor coils, generating a magnetic field that interacts with the rotation of the flywheel and consequently converts kinetic energy into electric energy, e.g. using a switched reluctance variable motor type. Regardless the form used to convert the kinetic into electric energy the amount of energy that can be stored in a flywheel is proportional to the momentum of inertia of the flywheel, and the squared value of the angular speed. So high angular speed flywheels store more energy than flywheels of high momentum of inertia (MEEKER e WALKER 2010).

In order to automatically switches between the two operation modes of such uninterrupted power supply systems, i.e., the charging and discharging mode, the design of an efficient control system becomes necessary.

The electrochemical and electromechanical batteries have their advantages, but an UPS needs a energy storage system, and in order to elicit the requirements of each battery type, allowing to analyze the two solutions and assisting the choice. The focus of this work is in eliciting the requirements using a new tool, called KAOS, which uses an object-oriented approach, but first this tool must be presented.

## 1.2 KAOS (Knowledge Acquisition in Automated Specification)

It is an object oriented approach, which generates a model aiming to facilitate the documentation and enables an argument or justification beyond the requirements analysis. This tool allows different levels of abstraction, because the application of the multi-paradigm model. This way, the model presents several levels of expression and rationale according with the part of the model:

- For the modeling and structuring goals: the KAOS present a semiformal language;
- For alternative selections, the tool presents a qualitative analysis and;
- For the critical elements, the KAOS uses the formal language.

A KAOS model has two layers: one is an external model, which is a graphic semantic layer with concepts, attributes and relationship; the second is an internal formal layer assisted by temporal logics (WERNECK, et al., 2009). The concept of goals can be defined as the intention which the system must satisfy, in other words, the KAOS model is based in the goals which the system must achieve, and consenquetly the subgoals which must be achieved by each system parts. The goals must be reached by satisfying the requirements of the system. So the KAOS first models the goals and after, the requirements (LAMSWEERDE, 2007).

In a system modeled by the KAOS approach, one identifies, formulates and analyzes the "what, why and who" for each system problems or obstacles: the "what" is an identification of the problem, the "why" includes the reason that jutify solving this problem and the "who" represents element or agents responsible for solving the problem. These concepts allow the modeling of a "system-to-be". In other words, KAOS modeling should be applied in a new system when several tentavie solutions are available for the same problem, requiring a relational analysis of all solutions against requirements to provide a proprer assistancy to select the "best" solution (LAMSWEERDE, 2009).

KAOS proposes four viewpoints for a problem that can be treated in four different models: the goal model, object model, responsibility model and operational model:

- The goal model is responsible for the modeling the goals, and postertly it will allow to present system requirements, where the model will show good aspects of solutions and its drawbacks. It also can be presented restrictions which must be respected;
- The responsibility model describes each agent, and its responsibility for each requirement or expectation. The agent is related with the object model.
- The object model is a model that describes domain proprieties and the restrictions of the operational parts of the system. Objects can be classified in three types: entity, agents and associations. The first are objects which can describe or change the state of other object, but it does not perform any operation, agents can perform operations and associations are dependent objects that also can not perform operations.

- The operation model introduces the necessary behavior for agents to meet system requirements. Operations depend on the requirements of the stakeholders and manipulate objects.

KAOS is a tool that allows the modeling of a "system-to-be", or, in other words, a system that will be developed according requirements, and not the replication of a system, which is called "system-as-is". Therefore, KAOS can be applied in both disjoint and close domain development: the first when the developer's domain is far from system domain, like a robot for medical application, and the second is when the developer's domain is close to the system domain, like the design of an UPS (WERNECK, et al., 2009).

## 2. OBJECTIVE

The objective of this paper is to review the development of an uninterrupted power supply (UPS), evaluating the application of the electromechanical battery based on a flywheel or the electrochemical battery. First, the UPS system is modeled using an object-oriented approach, the KAOS method. After this step, an object model is presented to show the difference between both solutions. It is expected that the KAOS method shows a second point of view for the UPS energy storage system. The motivation of the present work is the increasing concern with the environment and the sustainable use of energy, e.g. the application of the flywheel allows electric energy storage without using chemical or toxic components and can be applied on electric cars, i.e. storing the braking energy which can be used to recharge the car battery, like the KERS (Kinetic Energy Restoration System) (CIBULKA 2009). So, despite those advantages of the flywheel, it has higher complexity than the electrochemical batteries because they need a special kind of bearings to operate at high angular speeds inside vacuum chambers. Moreover special types of motor/generator and flywheel materials must withstand high stresses rates.

## 3. DEVELOPMENT

The modeling of the design starts with the KAOS method, the motivation to use this method is the modeling through goals. This development is classified as close domains (QUEIROZ 2009), which means that the domain of the application and the development is close, and some requirements are obtained from papers and others documents. However even in those cases, in the close domain, it is necessary a method that guarantees the modeling of functional and not functional requirements and ensures that there is no large influence of a particular viewpoint (RESPECT-IT 2007 and LAMSWEERDE 2003). In other words, the KAOS method and this model should avoid the development of "one shot" design, which already has the solution for the develop problems.

The focus of the artifact is energy storage system for an UPS system, but the goal model of KAOS is based in the top-bottom method, so the model starts with the UPS system, which needs an energy storage device and a control system: the first one is responsible for store energy and the second one is responsible to evaluate and control the power supply and the energy storage, as can be seen in Fig. 1.

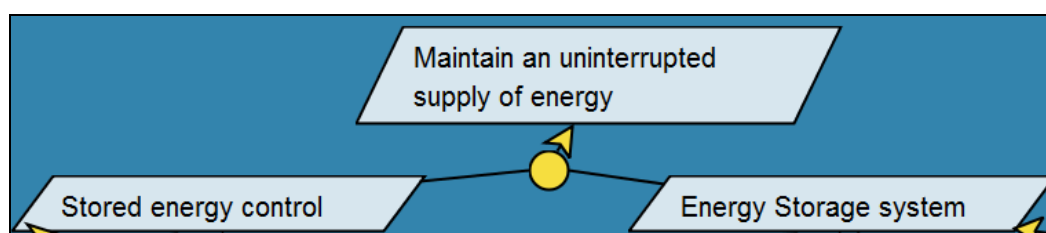

Figure 1 - First step of the KAOS model of the uninterrupted power supply system.

The main objective is to model known requirements, while the next step is to enhance the model shown in Fig.1. Such improvement will show requirements expected by the energy storage, which are done basically by the following design parameters:

- The phase controller for charging and discharging;
- Damage caused by the break of the casing;
- Storage power density and;
- The number of charge and discharge cycle.

These design parameters will be considered in two possible solutions: the electrochemical battery and the flywheel. Analyzing the requirements and the solutions, one can notice that the advantage of the electrochemical battery is the control system, once these batteries use a spontaneous chemical reaction to provide electric energy in discharging process. The charging process is also simple: it just needs an adequate voltage applied to the battery terminals to invert the chemical reaction and charge the battery.

Different from that, the flywheel needs a motor generator to provide and store electric energy. If we want to increase the efficiency of these motor/generators, it would be necessary a control system including sensors to monitor the rotation and the electric current of the system.

The other part of the model, the energy storage control, is responsible for making the interface with the user, that is, the controller must warn the user that there is a lack of electric energy and, if the lack of electric energy stays beyond a threshold value, the user must be warned to shut down the connected system.

Another function of the energy storage control is to monitor the variation or instability in the supply network, i.e. a large variation in voltage. Finally, this feature should control the charging and discharging phase of the energy storage system.

A KAOS model with all the enhanced features is presented in Fig. 2. Here, the requirements mentioned above are represented by parallelograms with borders in bold. As commented before, it is a model based on goals of the uninterrupted power supply system.

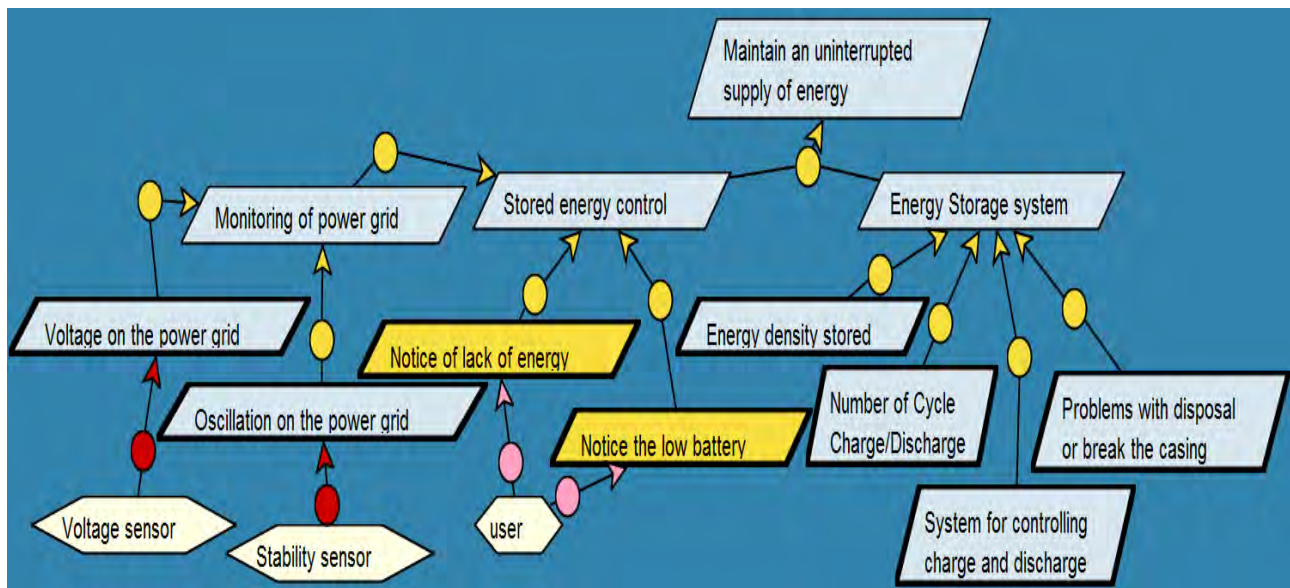

Figure 2: KAOS model of the uninterrupted power supply

After modeling the requirements, the next step of the development cycle is the system modeling. For this purpose, an object oriented methods (Naked Objects) is used. This method is suitable since it allows reusability. In other words, it can model the uninterrupted power supply system similarly to a no-break device, and it allows the model to accept the flywheel energy storage system.

Therefore, the idea is to start with a model for the UPS without worrying about the energy storage system, and reuse some parts in both solutions. After this first step, we intend to obtain a model of the UPS using a flywheel energy storage and compare it with another power supply system that uses electrochemical batteries (FERNANDES 1999).

The object oriented modeling starts with a class diagram, represented generically by the main classes/objects of the system. Partial solutions and improvements will be introduced by the refinement of the object “Power Supply System”, considering their subsystems, or parts of subsystems (CAPRETZ 2003 and MANSSOUR 2002). Therefore, the abstract model represents only the interaction among the user, the electric network, the system to be energized and the power supply system, as shown in Fig. 3.

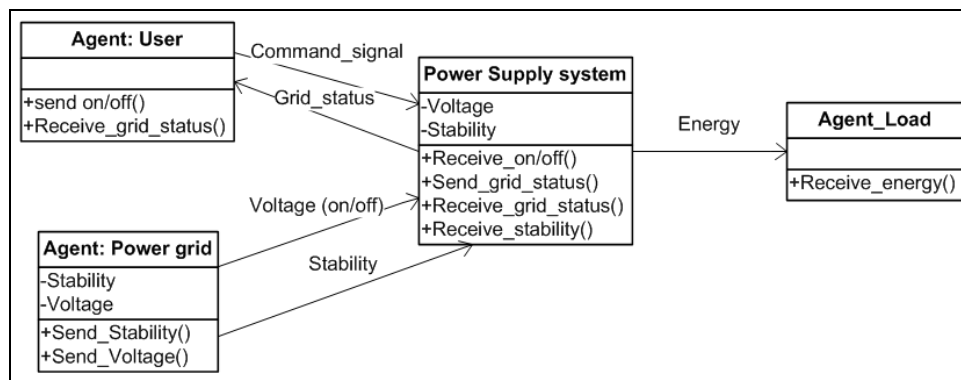

Figure 3 - Object Oriented Modeling, general model.

In order to develop the subsystems, it is necessary to refine some objects, like "Power Supply System". This is done by looking for subsystems necessary to ensure the right operational behavior of this object, with respect to the requirements showed in KAOS model.

In the refinement, it is necessary to find the objects responsible for the interfaces between agents: the user, the electric network and the internal systems (like the controller), the energy storage etc. Therefore, the model will present new objects, which raises its complexity, as can be seen in Fig. 4.

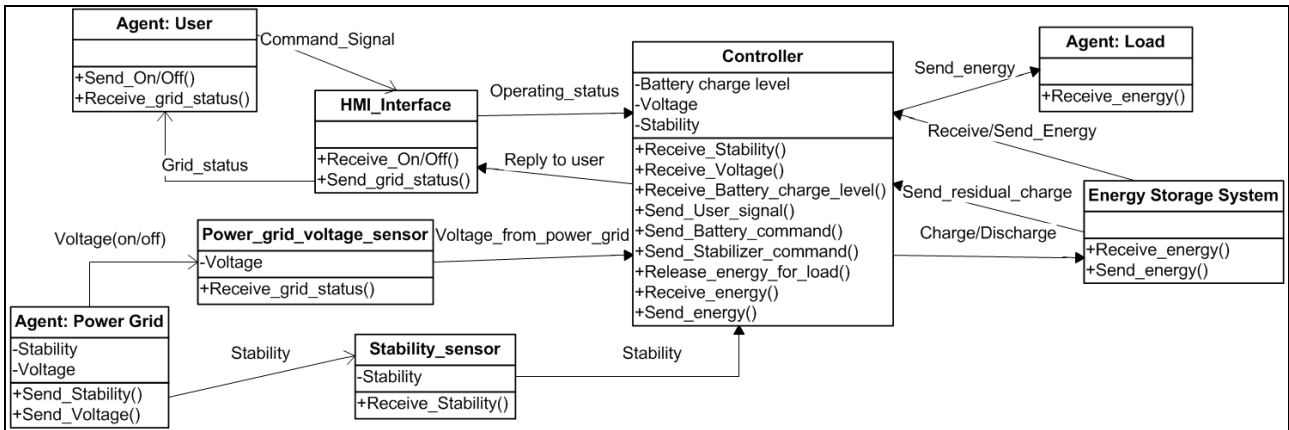

Figure 4 - Object Oriented model after the first improvement

Figure 4 also shows the objects responsible for the interface between the system and the external environment. Examples of these are sensors and the HMI (Human Machine Interface). Sensors are responsible for obtaining from the electric network, information like stability and the existence of energy in the network. HMI receives and sends information originated by the controller to the user. The controller will operate based on information received by sensors. The HMI sends signals to the energy storage system so as to control the charge or discharge process based on the energy level and the stability of the electric network.

Up to this point, the model showed in Fig. 4 stands for an UPS which can use both energy storage device: electrochemical battery or flywheel. Therefore, this model can be reused in a future design independent of the decision concerning which device is to be used. Hereafter, we are ready to choose one of the possible solutions for the energy storage, and we will use such flexibility in this paper to compare solutions using the flywheel with the one using electromechanical battery.

Initially the object "Energy Storage System" will be improved to allow the development of the controller and the flywheel for energy storage, as shown in Fig. 5.

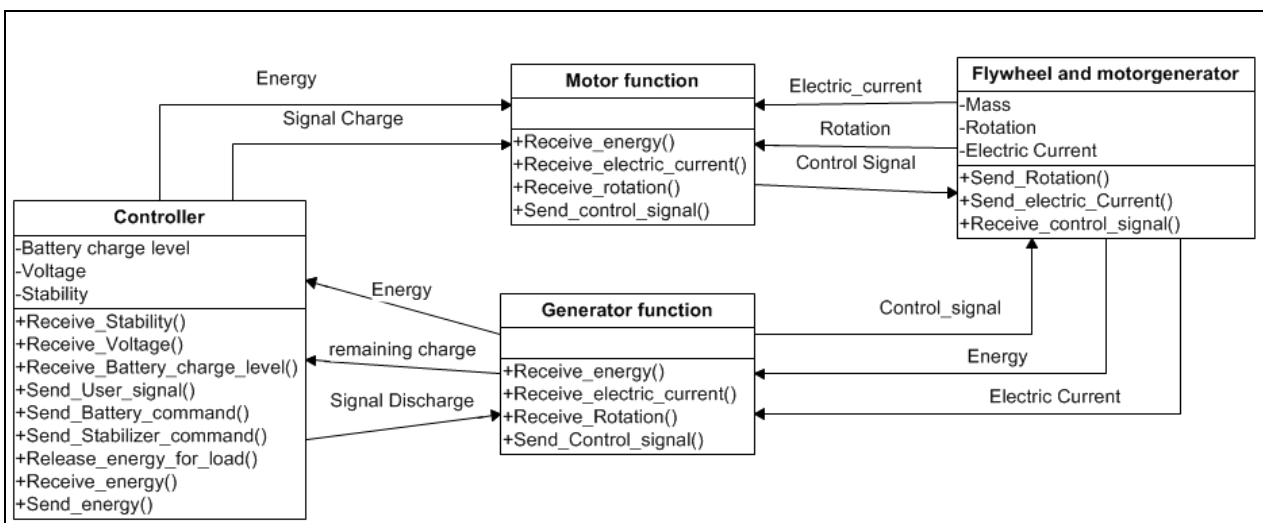

Figure 5 - Improvement of the energy storage

R. I. YAMAMOTO, O. HORIKAWA, J. R. SILVA and I. SILVA  
Study of the Requirements for the Development of a Flywheel Energy Storage

In Figure 5, the function of the motor and of the generator was separated. This was done since the task that each operation requires, as well as, the logic of each operation is very different. For example, the motor uses the controller to raise its efficiency. If the motor is of reluctance type, two actions are required:

- Make the control parameters to be in accordance with the rotation speed and;
- Brake the disc, because the disc stay in vacuum.

The control system of the generator must concern about converting the kinetic energy stored in the disc into electric energy. To do this, the generator has to send an electric current to the coil, thus generating a magnetic field that varies according to the disc speed, finally generating electric energy. This is necessary because, in this design, the motor and the generator do not use permanent magnets. So, there is no magnetic field without electric current through coils.

It should be noticed that, in the model, no sensor is used for electric current, or for rotation. This feature is important in order to keep the simplicity of the model. However, both sensors are included inside the object called "Flywheel". In other words, it is possible to refine a few steps further in this model, specially the object called "Flywheel".

The object "Flywheel" could be divided in several parts like sensors (as discussed above). But inside of this object, another object, the "Bearings of the flywheel", is encountered. This has several solutions such as: a ceramic bearing with low friction and great durability or a magnetic bearing of several kinds. This design considers a electromagnetic bearing, which needs sensors and control systems. These objects are included in other objects belonging to the "Flywheel".

However, the focus of this paper is in the development of the uninterrupted power supply system. Thus, the last improvements discussed above, is not relevant for the final goal, which is the modeling of the signal of the flywheel and the energy control system showed in Figs. 4 e 5.

In order to compare the possible solutions for the energy storage system, it was done an equivalent model that stands for an uninterrupted power supply system using electrochemical batteries; this model is showed in Fig. 6.

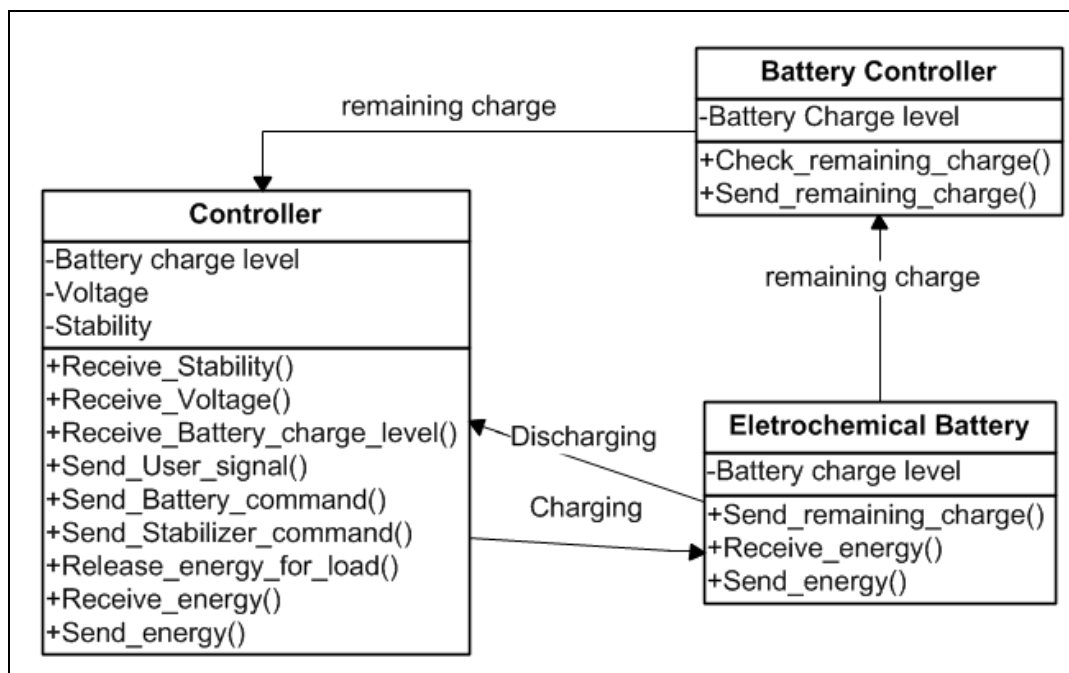

Figure 6: Model with electrochemical battery for energy storage.

It is noted that there is no great changes between the model shown in Fig. 4 and that, in Fig. 6. This happens due to the fact that the electrochemical battery is easier to be controlled, and needs only a system to check the charge level in the battery. However, this simplicity also brings some problems. For example, the electrochemical batteries cannot notify when there is a problem in the battery casing, because there is no sensor for this end. However, in the flywheel, the controller can detect abnormal situations through sensors for rotation speed and electric current, once the aerodynamic friction raises when the casing broke.

The amount of charge and discharge cycle is not controlled in any solution. However, the durability of the flywheel is higher than the one of electrochemical battery. The environment damage, which is also a valuable requirement, is smaller in the flywheel, because the breaking of the flywheel casing does not cause any pollution and it also can work with the casing broken barely affecting its efficiency. In electrochemical batteries, the breaking of the casing causes



failure in the battery because it causes an unbalance in the chemical products, besides it causes damage to the environment and the users.

Present results show that the flywheel, although being more complex and having more variables, turns out to be a solution that best fits the requirements, compared to electrochemical batteries.

#### 4. CONCLUSION

After reviewing the uninterrupted power supply (UPS) system through the KAOS method, another possibility for the energy storage system has been studied. This tool demonstrated its effectiveness in the development of artifacts and devices, allowing to review the design inserting a new solution without change the other parts of the system. This shows that the KAOS method can expand the number of the solutions assisting the innovation process, even in the close domain.

This paper showed that, even specific designs like the UPS system with electrochemical batteries, can be reviewed using KAOS method in order to find another solutions for problems. Also others problems could be analyzed by this method. The object oriented model develop in this work for the UPS can be used for a system composed either by an electrochemical battery or a flywheel for energy storage. This allows to decouple parts of the development or the review, and also to develop all system independently of the chosen solution for the energy storage system because each object has a different functionality.

An evaluation of the requirements for each solution to energy storage allows to perceive that among the four requirements modeled by KAOS method, the electrochemical battery is the best to meet just one of them, the controller of the energy storage, but it does not fit the other 3 requirements, in special the damage caused by the break of the casing which generate a failure of the system and environmental damage. And this evaluation was allowed by the KAOS model, because others evaluations criteria define the electrochemical batteries like the best solution.

Differently, the flywheel, despite of the complexity of the controller, fits better all others 3 requirements, like: amount of charge and discharge cycles, the consequence of a break of the casing and the energy density.

Once evaluated the best solution, the improvement process can be started. The development is concluded without modifying the remaining of the model, thus facilitating the development of complex systems. The studied case allows an analysis of requirements to decide the better type of magnetic bearing for increasing the efficiency of the system, without affecting the remaining of the design. The development process is thus speeded up.

This work showed the advantage on the UPS design considering a flexible approach to requirements elicitation. Such analysis strategy leads to a design process in which, critical decisions can be postponed, strength is enhanced and the design centered in an unique solutions is avoided, while opening possibilities for concurrent design. Also, it is worth to highlight the possibility for keeping the documentation of different alternatives.

#### 5. REFERENCES

- CAPRETZ L. F. A Brief History of the Object-Oriented Approach [Periódico] // ACM SIGSOFT - Software Engineering Notes. - 2003.
- CIBULKA J. Kinetic Energy Recovery System by means of flywheel energy storage [Periódico] // Advanced Engineering. - 2009. - p. 3.
- FEDERAL TECHNOLOGY ALERTS EERE: Federal Energy Management Program Home Page [Online] // Flywheel Energy Storage An alternative to batteries for uninterruptible power supply system. - September de 2003. - 2012 de December de 14. - <http://www.edsenerji.com.tr/userfiles/files/Federal%20Alert.pdf>.
- FERNANDES H. C. J. Padrão de Design Orientado a Objetos [Online]. - Junho de 1999. - 23 de november de 2012. - <http://www.cic.unb.br/~jhcf/MyBooks/iess/Patterns/PatternsIntro-25slides.pdf>.
- LAMSWEERDE A. Apresentação de Axel van Lamsweerde [Online]. - May de 2003. - 2012 de december de 15. - <http://www.objectiver.com/fileadmin>.
- LAMSWEERDE A. Reasoning About Alternative Requirements Options [Seção do Livro] // Conceptual Modeling: Foundations and Applications / A. do livro GORGIDA A. [et al.]. - [s.l.] : Springer, 2009. - Vols. 380-397.
- LAMSWEERDE A. Requirements Engineering: From Craft to Discipline [Artigo] // IEEE-Sifgoft. - 2007.
- MANSSOUR I. H. Paradigma Orientado a Objetos [Online]. - 1 de october de 2002. - 23 de november de 2012. - <http://www.inf.pucrs.br/~gustavo/disciplinas/pli/material/paradigmas-aula12.pdf>.
- MEEKER N. e WALKER B. Flywheel Technology for Energy Storage [Online]. - 24 de February de 2010. - 14 de december de 2012. - [http://www.nicholasmeecker.com/files/flywheel\\_report.pdf](http://www.nicholasmeecker.com/files/flywheel_report.pdf).
- POST R. F. A new look at an Old Idea The Electromechanical Battery [Periódico] // Science & Technology Review. - 2006. - pp. 12-18.
- RESPECT-IT A KAOS Tutorial [Online]. - 18 de july de 2007. - 2012 de December de 14. - <http://www.objectiver.com/fileadmin/download/documents/KaosTutorial.pdf>.

R. I.YAMAMOTO, O.HORIKAWA, J. R. SILVA and I. SILVA  
Study of the Requirements for the Development of a Flywheel Energy Storage

WERNECK VERA MARIA BEJAMIM, OLIVEIRA ANTONIO DE PADUA ALBUQUERQUE e LEITE JULIO  
CESAR SAMPAIO DO PRADO Comparing GORE Frameworks: i-star and KAOS [Periódico] // Ibero-American  
Workshop of Engineering of Requirements. - 2009.

ZANEI G. [et al.] Integrated Systems for UPS: New solutions in the power quality chain [Artigo] //  
Telecommunications Energy Conference - INTELEC 2007. - 4 de October de 2007. - pp. 582-586.

## **6. RESPONSIBILITY NOTICE**

The authors are the only responsible for the printed material included in this paper.