



ROBOT FOR INSPECTION OF WELD ROOT IN PIPE MANUFACTURING

Luis Henrique Vieira Amaral

Giuliano Gonçalves de Souza

Mechanical Engineering Department, Universidade de Brasília, Brasília, DF – Brazil, 70910-900
luis.amaralh@gmail.com; giuliano.robotic@gmail.com

Walter de Britto Vidal Filho

Mechanical Engineering Department, Universidade de Brasília, Brasília, DF – Brazil, 70910-900
wbritto@unb.br

Abstract. *This paper describes the development of a robot for weld root inspection in ducts during the line manufacturing process. The root integrity of the weld bead is an important element in this process and must reach the standards established. A robot was customized to evaluate and measure the root weld and move by wheels inside the duct with a camera on board. The aim of this paper is to describe the robot systems, such as control software and vision system used to measure the root. The main task of inspection is to find and quantify, using image, possible defects in the weld and in the process, such as forgotten spacers and gaps, etc.*

Keywords: *Robot, Welding Root, Duct Inspection*

1. INTRODUCTION

This paper discusses the development of a robot for inspection of weld root in ducts during the manufacturing process line. The importance of the duct grid can be measured by the duct quantity in Brazil, which had 22,000 km of built pipeline, terrestrial and submarine, until 2010 (Gasnet, 2010). This amount is considered insufficient when compared to the pipeline grid of other smaller countries, such as Argentina that has 38,000 km of pipelines built in the same year (Gasnet, 2010). There is thus a need for more duct line that must be built in the next years. The building process consists of align the pipes which have an average of 12-meter in length and 15 inches in diameter. Then the joints are welded and protective coating may be done when necessary. In Brazil it is employed primarily the manual process GTAW (Gas Tungsten Arc Welding) for root pass and SMAW (Shielded Metal Arc Welding) for filling and finishing passes (Ramalho son et al, 2008). This manufacturing process is performed in the field under difficult conditions which favor the appearance of defects in the joints. The inspection is a mean of ensuring the quality of the process. The inspection usually starts by visual inspection followed by ultrasound, which evaluates the interface between the weld and the tube, other inspection techniques are also employed. Some problems like forgetting spacers or other materials inside the duct and defects in the weld roots are not easily identified by ultrasound. A robot capable of entering the duct and visualize the weld and the inside area of the duct can identify these problems during the manufacturing line. With this purpose a robot was developed to inspect the root of the weld. This robot can, besides visual inspection, carry other sensors to perform other types of inspection as ultrasound or x-ray. The development process was based on reverse engineering using a robot scrap supplied by the Inspectronics Company. The robot was modified to meet this goal. The device was donated without the control software and presented problems in electronic traction control and lighting system.

2. THE STATE OF THE ART

Automated devices used in pipeline inspection can be motorized or pushed. Impelled systems are known as PIG (Pipeline Inspection Gauge), because they move into the duct propelled by transported fluid (fig. 1). PIGS are used for inspection of pipelines over long distances, have no communication with the base and make the data collection automatically. They are employed to measure the duct geometry and the variation in thickness due to corrosion, using mechanical contact sensors, ultrasonic sensors or magnetic sensors. The magnetic PIG can be seen in figure 2.

The motorized systems known as PIC (Pipeline Inspection Crawler) can be used for external or internal inspection of the pipeline. They are applied to small distances in pipeline with variable diameters and closed curves which are obstacles to the PIGs. They are most commonly used in visual inspections, but can do inspections with sensors such as ultrasound. PICs have communication with the base and are usually remotely operated. In Figure 3 there is an external PIC developed in Brazil (Instor, 2013) which employs ultrasonic sensors to identify corrosion.

Amaral, L. H. V., De Souza, G. G. and Vidal Filho, W. B.
Robot for Inspection of Weld Root in Pipe Manufacturing

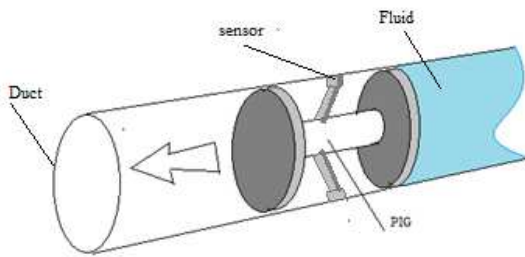

Figure 1. PIG Scheme



Figure 2. PIG magnetic (Admironews, 2013)

An internal inspection system also developed in Brazil can be seen in Fig.4. This system employs wheels and camera for visual inspection (Subin, 2010). This PIC usually has an umbilical cable connecting the base to the robot, which can transmit commands, images and energy.

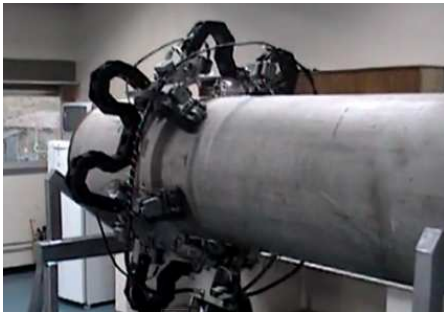

Figure 3. PIC for external inspection (Instor, 2013)



Figure 4. PIC for internal inspection (Subsin, 2010)

There are several configurations of pipeline inspection robots. The main differences are in the locomotor system and in the applications. In figure 5 we can see the "Girino" robot, developed by CENPES (Research Center of Petrobras), which moves imitating an animal, expanding and contracting the body. "Girino" was developed to unclog pipes (Panta,2005).



Figure 5. Girino Robot (Panta, 2005)

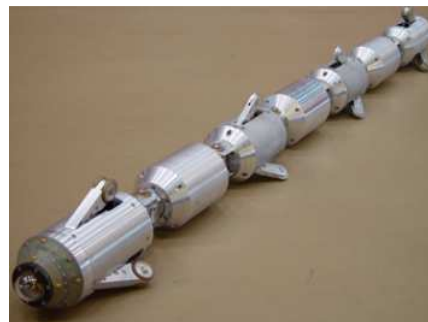

Figure 6. Explore Robot (Schempf et al, 2003)

In Figure 6 it is shown a robot used in the inspection of gas pipelines, developed in the United States. This robot employs legs and wheels in a multi-jointed body (Schempf et al, 2003).

3. ROBOTIC SYSTEM DESIGN

The design methodology for mechatronic systems, as any other design methodology, accordingly to Pahl and Beitz (1996), includes the following phases: abstraction, analysis, and synthesis. A design has an initial phase of problem determination, a stage of developing a concept, a detailing phase and finally validation. Some authors tend to divide a project into a simplified conceptual design and detailed design (Vidal Filho, 2010), others in the viability study, pre-design and detailed design (Madureira, 2010), there are more detailed methodologies, subdividing the project in

informational, conceptual design, preliminary design and detailed design (Da Luz, 2008). The aim of the methodology is to ensure the search for the best design solution.

The design begins by analyzing the needs and transforming it into design requirements. In this stage should be reviewed the state of the art and benchmarking tables (Da Luz, 2008). The evaluation of the order of importance of each requirement can be made using the QFD method (Quality Function Deployment) which allows determining the specific objectives for each requirement.

A systemic analysis or a functional decomposition of various design elements can be made in solution synthesis.

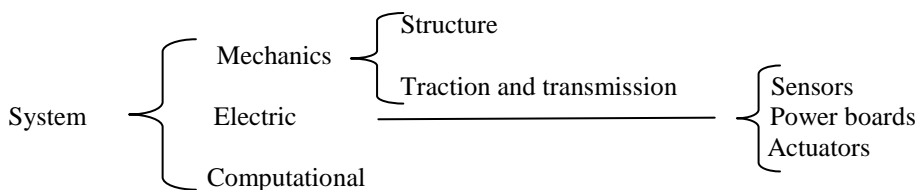

Figure 6. Systemic analyses

The design starts by analyzing an existing system, using reverse engineering, aiming initially to analyze the donated robot and put it into operation, then optimize the system and thus skip some phases of classic design.

3.1 Analysis and Documentation System

The mechanical structure and layout of the electrical components were initially documented through CAD drawings (Fig. 7). Then each subsystem was tested individually and malfunctions were identified. All the subsystems that were not working properly were identified and fixed when it was possible, after this the improvements needed were identify to meet the desired purpose. The robot has a pan-tilt system servo controlled to position the CCD camera. The lighting system consists of two headlamps at the front and a mini lighthouse connected to the camera system, allowing the lighting to move along with the camera.

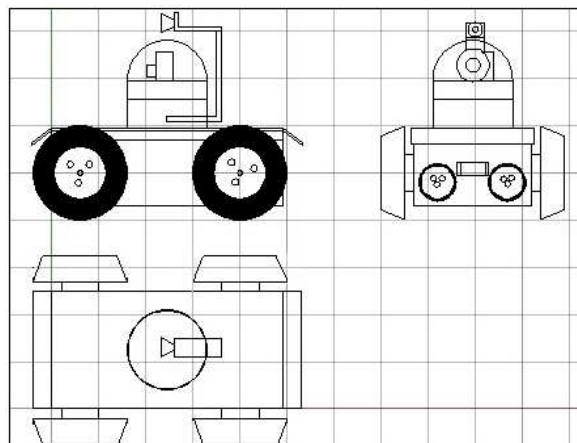

Figure 7. CAD design of the robot

The robot includes all the electronic subsystems seen in Fig. 8. It is observed that the computational part of the robot runs on an external PC that communicates with the vehicle by cable. This permits to use a computer system more complex that would not run on an embedded microcontroller.

Amaral, L. H. V., De Souza, G. G. and Vidal Filho, W. B.
Robot for Inspection of Weld Root in Pipe Manufacturing

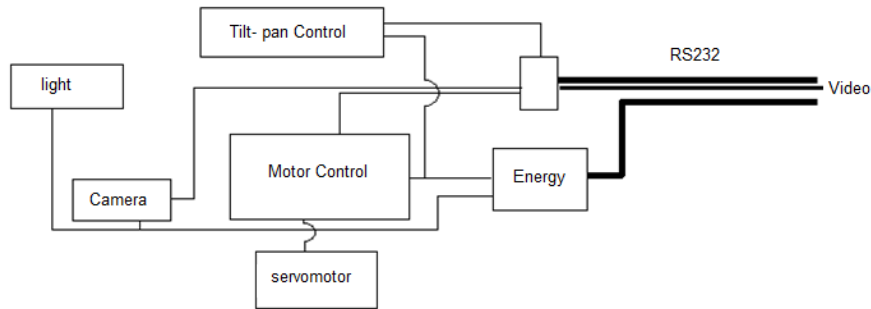

Figure 8. Scheme of electronic subsystems

3.2 Mechanical Analysis and Optimization

The necessity of improve some points was identified when analyzing the robot: the ability to climb higher slopes and the camera placement to facilitate the inspection. In the figure below it is possible to observe that if the defect position is below the vehicle, the vehicle cannot get too close, because the defect may be out of line of sight.

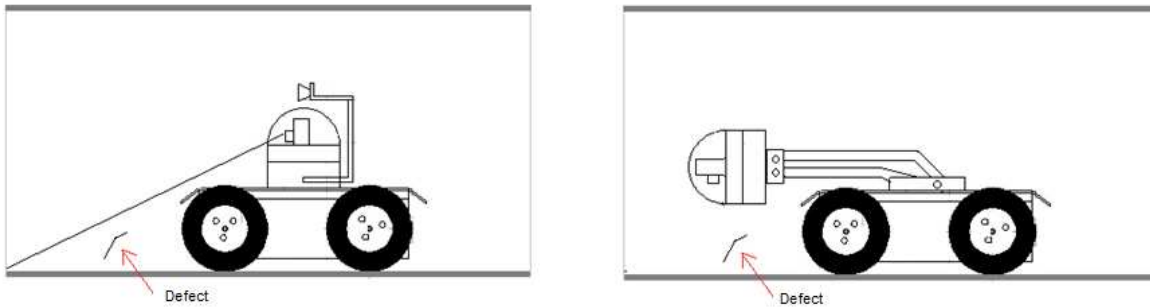

Figure 9. Camera positioning

To improve the tilt angle of the ascent robot some solutions were analyzed: insert a mechanism to push the vehicle against the base or a magnetic system that attracts the robot against the base. In Figure 10 there is a picture of the robot.



Figure 10. Robot picture

4. VISUAL INSPECTION SYSTEM

The visual inspection system should allow the measurements of localized defects and not only realize a qualitative analysis in order to obtain the length and width of the defects using a computer vision system. The geometric parameters of the robot and of the tube are known.

The process of forming a plane image can be modeled as an ideal quite simple device, the pinhole. This is a box with opaque walls containing a very small hole through which light enters and forms the image. Knowing the camera model, the dimensions of the pipe and the location and orientation of the robot, it is possible, by triangulation, determine the approximate geometry of a discontinuity in the root bead deposited to connect the tubes. The main parameters are shown in Figure 11: the pipe radius R , the CCD camera and the observed point P_1 and P_2 , which represent the edges of the defect.

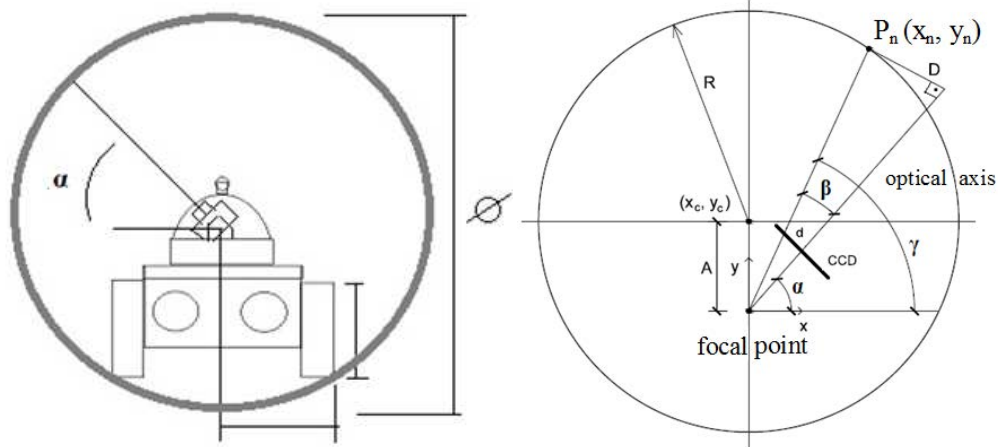

Figure 11. Geometric parameters of the system

The vision system has as input a plane image captured by the camera onboard the inspection robot and as its output the distance C between the points P_1 and P_2 that define the edges of discontinuity S at the root of the weld, shown in Figure 12 (a). The points P_1 and P_2 are defined by the operator of the system in a visual inspection on the plane image, shown in Figure 12 (b).

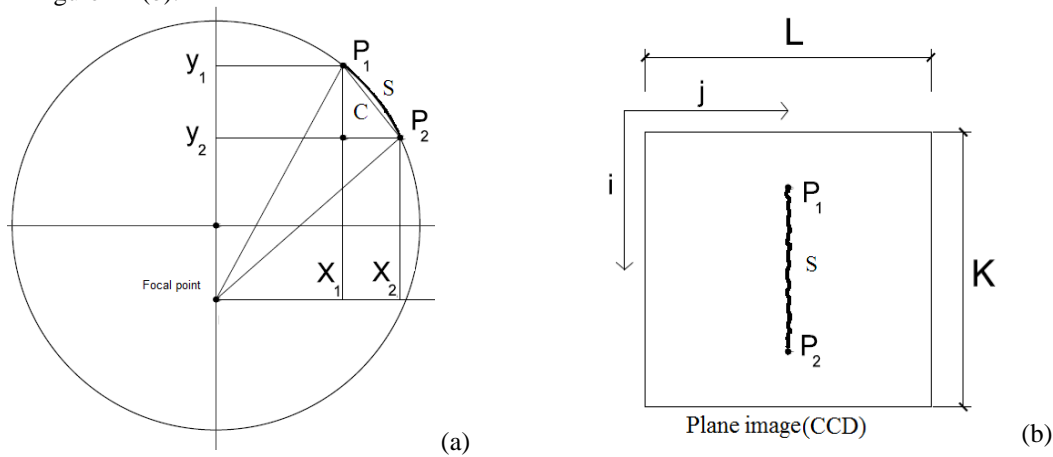

Figure 12. Location of discontinuity S

In Figure 12, L and K are the dimensions of the CCD pixels. The angle β is determined by triangulation, using the parameters defined in Figure 13.

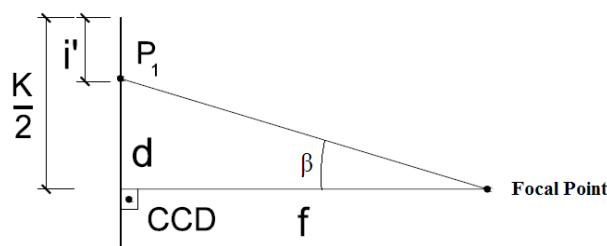

Figure 13. Triangle image projection in CCD camera

Amaral, L. H. V., De Souza, G. G. and Vidal Filho, W. B.
Robot for Inspection of Weld Root in Pipe Manufacturing

The mathematical model of the system was developed using geometric equations, which are shown in the Equations: 1, 2, 3, 4, 5, 6, 7, 8, 9, 10 and 11.

$$d = \frac{k}{2} - i' ; \quad (1)$$

$$\tan \beta_n = \frac{d}{f} ; \quad (2)$$

$$\tan \beta_n = \frac{k-2i'}{2f} ; \quad (3)$$

$$(x_n - x_c)^2 + (y_n - y_c)^2 = R^2 ; \quad (4)$$

$$(x_n)^2 + (y_n - A)^2 = R^2 ; \quad (5)$$

$$x_n^2 + y_n^2 - 2y_n A + A^2 = R^2 ; \quad (6)$$

$$\beta_n = \tan^{-1} \frac{k-2i'}{2f} ; \quad (7)$$

$$\gamma_n = \beta_n + \alpha ; \quad (8)$$

$$y_n = x_n \tan \gamma_n ; \quad (9)$$

$$x_n = (A \tan \gamma_n + \sqrt{-A^2 + R^2 + R^2 \tan^2 \gamma_n}) / (1 + \tan^2 \gamma_n) ; \quad (10)$$

$$C^2 = (x_2 - x_1)^2 + (y_1 - y_2)^2 ; \quad (11)$$

In this equation, $i' = i * \text{pixel dimension}$, $x_c = 0$ and $y_c = A$, $x = y / \tan \gamma$ and $\alpha + \beta = \gamma$.

The size of the discontinuity S is represented approximately by the line C and enables decision making regarding the relevance of the defect in the weld.

5. CONCLUSION

In this paper it was described reverse engineering of adapting a robot to weld root inspection. Initially, the robot scrap was put into operating conditions. A software that allows the serial and parallel communication with traction control plates and the pan-tilt camera was developed After that it was analyzed and proposed improvements to mechanical adaptation of the robot. The next step in this project is to implement mechanical modifications to allow the robot to climb higher slopes and include a system of camera placement that facilitate the inspection.

6. REFERENCES

- Admironews, 2013. "PIGs" 1 jun. 2013 <<http://www.admironews.com.br/p/maquinas-equipamentos.html>>.
- Da Luz, A. A. D.; Katsumi, E.; Cziulik, C., 2008 ; "Desenvolvimento de um dispositivo mecânico para inspeção não destrutiva de cascos de navio plataforma", In: *4º Congresso Brasileiro de Pesquisa e Desenvolvimento em Petróleo e Gás*, Campinas, Brasil.
- Gasnet, 2010. "Gasodutos", 10 jun. 2013 <<http://www.gasnet.com.br/conteudo/9495>>.
- Instor, 2013. 10 jun. 2013 <<http://www.instor.com.br>>.
- Madureira, O. M., 2010 "Metodologia do Projeto: Planejamento, Execução e Gerenciamento", Ed. Edgard Blucher, São Paulo, Brasil
- Panta, P. E. G. 2005, "Monitoramento de robô de inspeção interna de oleodutos - Girino", Dissertação de mestrado, UFRJ, Rio de Janeiro, Brasil.
- Ramalho Filho, F. A.; Lima II, E. J.; Bracarense, A. Q., 2008; Felizardo, I.; "Robótica Industrial de Campo: Novas Ferramentas para a Construção de Dutos", *XXXIV Congresso Nacional de Soldagem*, CONSOLDA 2008, São Paulo, Brasil.
- Schempf, H., Mutschler, E., Goltsberg, V. , Skoptsov, G., Gavaert, Vradis, G., 2003 "Explorer: Untethered Real-time Gas Main Assessment Robot System", In: *1st International Workshop on Advances in Service Robotics*, ASER'03, Bardolino, Italy.
- Subsin, 2010, 1 jan. 2013 <www.subsin.com.br>.
- Vidal Filho, W. B. ; Avila, R. ; Quintero, C. H. L. ; Rudi H van Els ; Queiroga, G., 2010 . "Desenvolvimento de Kit para automação de cadeira de rodas convencional". In: *VI Congresso Nacional de Engenharia Mecânica- CONEM 2010*, Campina Grande, Brasil.

22nd International Congress of Mechanical Engineering (COBEM 2013)
November 3-7, 2013, Ribeirão Preto, SP, Brazil

7. ACKNOWLEDGEMENTS

The authors thanks to *Inspectronics ltda* for donating the Robot components and the Petrobras S.A by scholarship for students.

8. RESPONSIBILITY NOTICE

The authors are the only responsible for the printed material included in this paper.