

# NOVEL TECHNIQUES FOR EXPERIMENTAL DETERMINATION OF THE RESTITUTION COEFFICIENT BY MEANS OF ACOUSTIC SIGNAL ANALYSIS

**Tarso Carvalho Ribeiro, tarso.ribeiro@ufabc.edu.br**

**Jesus Franklin Andrade Romero, jesus.romero@ufabc.edu.br**

**Javier Alexis Andrade Romero, javier.romero@ufabc.edu.br**

Universidade Federal do ABC, Rua Santa Adélia, 166, Bairro Bangu. Santo André – SP – Brasil

***Abstract.** Frequency based digital signal analysis has already established a relevant place in nondestructive testing. With digital signal processing techniques aid, it is possible to find patterns in spectrum signals to increase efficiency and minimize costs with maintenance of industrial equipment. In 2009, industrial maintenance spending corresponds to 4.14% of world GDP. In Brazil, in 2008 this market spend R\$ 120 billion in 20 sectors of the industrial economy. As predictive maintenance can be implemented using digital signal processing, this work explores new procedures which should help lower costs in the industry by means of the restitution coefficient estimative analysis. As the restitution coefficient is a physical property related to the structural condition of a material, the goal of this work is present a new algorithm considering a setup based on different materials, a differential amplifier circuit, an electret microphone and frequency based analysis of impact acoustic signals. The main contribution of the work consists in establishing a direct relationship between the slope of a spectrum signal interpolation and the restitution coefficient, considering five different materials, in order to obtain new estimation algorithms for structural properties evaluation.*

***Keywords:** Spectral analysis, Restitution Coefficient, Digital Signal Processing.*

## 1. INTRODUCTION

Monitoring procedures for physical properties variations in industrial equipment (restitution coefficient for example) is a key issue in sectors such as mineral, material processing, as well as petrochemical and construction. Over the last years, spectral analysis has emerged as a powerful tool for structure evaluation. Extensive research has been carried out to develop several methods to estimate material fragmentation or degradation in impact processes. In this sense, this work proposes a novel methodology in order to identify different types of materials through the restitution coefficient estimative.

Measurement of the restitution coefficient considering a setup that involves a collision between a ball and a flat surface (table), using the sound produced by the impact, has been of interest considering educational experiences Azzoni, A. and De Freitas (1995), Bernstein (1997), Cavalcante et al. (2002) and Stensgaard and Lægsgaard (2001), and industrial applications Andrade et al. (2006, 20076), Giani et al. (2004) and Cavalcante et al. (2002), as well. The standard procedure used in these studies considered a ball falling down vertically from a given height, obtaining several impacts with the table before settling down. The goal of this work is develop an estimations algorithm for the restitution coefficient considering four different materials (steel, glass, resin and a hollow plastic) and, by means of spectrum analysis procedures applied to acoustic signals, obtain an estimative considering a single impact. The main experiment consists in three steps: a) a material free falling of approximately 60 centimeters high, b) digital sampling of the impact acoustic signal, and c) Discrete Fourier analysis.

In section 2, the restitution coefficient property is presented. Section 3 presents the experimental setup used in the estimation procedure. The proposed method is described in section 4. A validation procedure is described in section 5 and the main conclusions are presented in section 6.

## 2. THE RESTITUTION COEFFICIENT

The restitution coefficient is a physical property used to measure the energy loss of a body after an impact event. Thus, is possible to define the coefficient of restitution as the ratio of orthogonal components of the velocities after and immediately before an impact, equation (1).

$$\varepsilon = \frac{v_1 \cos \theta_1}{v_0 \cos \theta_0} \quad (1)$$

Where  $v_0$  represents the speed immediately before an impact and  $v_1$  the speed immediately after and  $\theta$  represents the angle of the material with the horizontal table. When the object collides orthogonally to the table, the impact is called normal, and the restitution coefficient can only be considered as the ratio between the modulus of the velocities

Guercio and Zanetti (1987), Andrade et al. (2006). As equation 2 shows, it is possible to calculate the restitution coefficient considering the time ratio between two consecutive intervals, generated by at least three impacts of the object with the floor Andrade et al. (2007). In equation (2) is presented a simple expression in order to calculate the restitution coefficient considering three consecutive impacts.

$$\varepsilon = \frac{\Delta t_2}{\Delta t_1} \tag{2}$$

In equation (2),  $\Delta t_1$  represents the time interval between the first and second impacts, and  $\Delta t_2$  the time interval between the second and third impacts.

### 3. EXPERIMENTAL SETUP

Several works consider the interval time between two consecutive impacts in order to identify the restitution coefficient. Unlike traditional methods, in this work a single impact interval is used to estimate the restitution coefficient using the Fourier transform and a simple pattern recognition technique implemented in MATLAB computing environment. The main contribution of this work consists in establishing a direct relationship between the slope of a straight, obtained through a linear interpolation of the spectrum signal, and the coefficient of restitution of each material. The schematic diagram of the acquisition system used in this work is presented in Fig. 1.

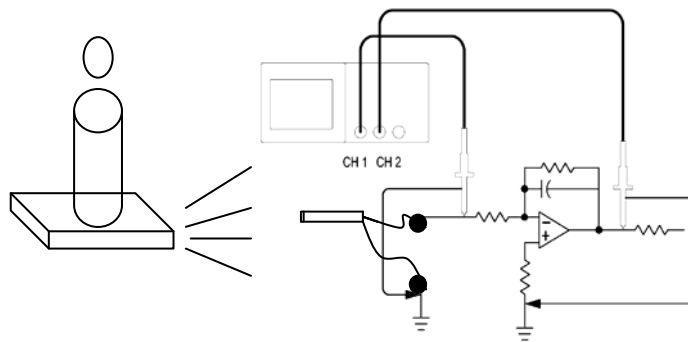

Figure 1. Experimental setup for the acoustic signal acquisition

As figure 1 show, the ball in analysis is dropped from a height of approximately 60 cm, and the resulting impact sound signal between the ball and the floor was acquired through the electret microphone and a digital scope.

Measurement of the restitution coefficient for a collision between a ball and a flat surface using the sound produced by the impact between the two has been of interest for fault detection applications Giani et al. (2004), Cavalcante et al. (2002). The standard procedure used in these studies has been based on a vertically free falling to allow from a given height and a large number of bounces with the table before settling down. Figure 2 presents an example for the impact case of a resin ball with a fixed table.

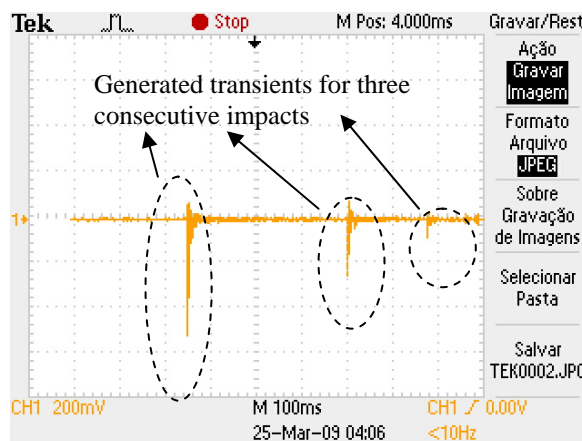

Figure 2: Signal generated by 3 consecutive impacts of a resin ball.

By means of equation (2) and the time intervals between impacts it is possible to calculate the restitution coefficient. Table 1 presents the restitution coefficient value considering four balls of different materials (steel, glass, resin and a hollow plastic) and 5 realizations.

Table 1. Experimental results for restitution coefficient of different materials

Material \ Impact	Steel ball	Resin ball	Glass ball	Hollow plastic Ball
1	0,675	0,759	0,770	0,962
2	0,670	0,771	0,779	0,962
3	0,670	0,746	0,729	0,949
4	0,678	0,748	0,768	0,963
5	0,659	0,750	0,800	0,962
Mean value	0,670 ± 0,014	0,755 ± 0,021	0,769 ± 0,052	0,960 ± 0,012

#### 4. RESTITUTION COEFICCIENT ASSESSMENT THROUGHT SPECTRAL ANALYSIS

The acoustic signal spectrum is obtained by means of the Fast Fourier Transform (FFT), Eq. (3), applied on Matlab®.

$$x(m) = \sum_{k=0}^{N-1} x_k e^{-jm \frac{2\pi}{N} k} \quad (2)$$

The spectrum analysis considered only one impact, between the ball and the table. In order to identify patterns on the signal five signals were captured for each material. The proposed methodology for identifying patterns considers two spectrum curve characteristics, the area below the spectrum curve and the slope spectrum curve.

Figure 3 illustrates four Fourier spectrums calculated from each material, them it is described the main characteristic identified in each one.

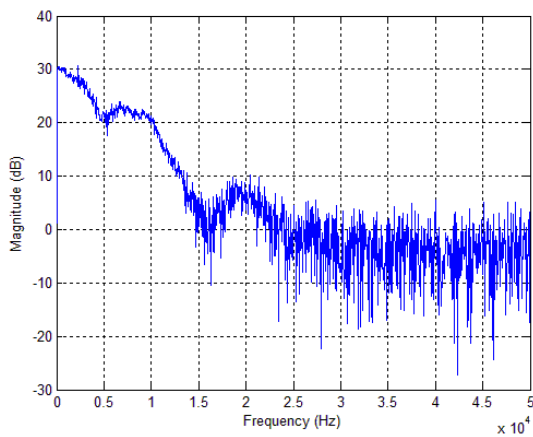

(a) steel ball

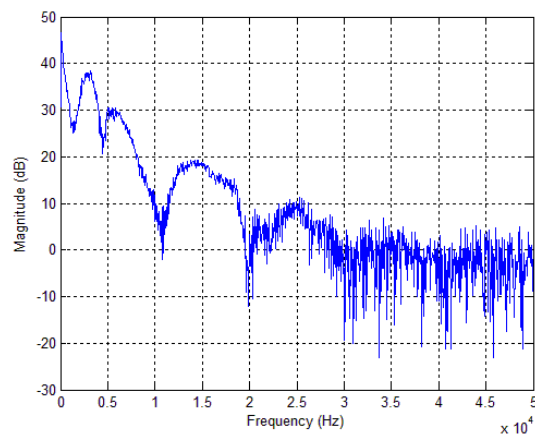

(b) resin ball

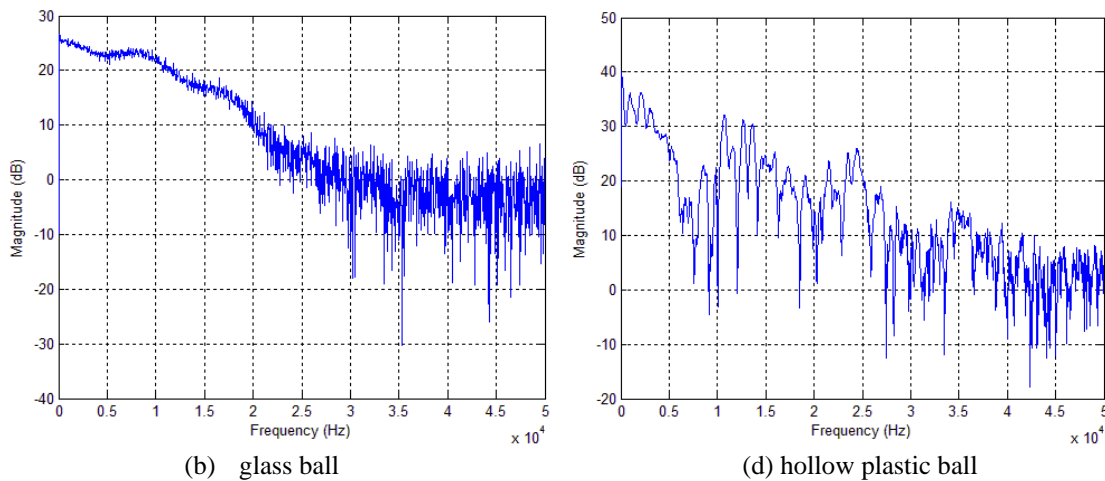

Figure 3: Fourier spectrums from each material analysis, (a) steel ball, (b) resin ball, (c) glass ball, (d) hollow plastic ball

The steel ball spectrum curve, Fig. 3 (a), depicts three small lobes and a rapid attenuation, i.e. the 0 dB magnitude is reached at 24 kHz, the resin ball spectrum curve, Fig. 3 (b), exhibits the greatest low frequency components, i.e. 40 db, the glass ball spectrum curve, Fig. 3 (c), shows a smooth curve with a accentuated attenuation after 15 kHz, finally, the hollow plastic ball spectrum curve exhibits the greatest high frequency components.

In order to identify patterns on the Fourier spectrum curve, there are analyzed, and quantified, two variables, the area under the spectrum curve and the slope spectrum curve.

#### 4.1. Delimited Area analysis

In order to determine the area under the spectrum curve, it is calculated the absolute values sum of the magnitude Fourier transform. The Fig. 4 shows the absolute values of the magnitude Fourier transform.

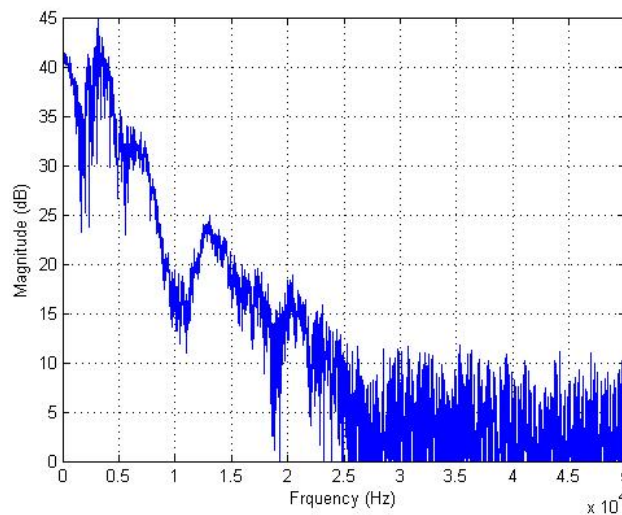

Figure 4: Absolute values of the magnitude Fourier transform of the resin ball.

The absolute values sum was obtained in Matlab®, and is presented in Tab. 2.

Table 2. Area's values for each experimentation

Material \ Impact	Steel ball	Resin ball	Glass ball	Hollow plastic Ball
1	$4,16 \times 10^4$	$5,21 \times 10^4$	$5,56 \times 10^4$	$7,08 \times 10^4$
2	$5,08 \times 10^4$	$5,68 \times 10^4$	$5,41 \times 10^4$	$7,64 \times 10^4$
3	$4,06 \times 10^4$	$5,51 \times 10^4$	$4,78 \times 10^4$	$7,90 \times 10^4$
4	$4,67 \times 10^4$	$6,13 \times 10^4$	$5,72 \times 10^4$	$6,73 \times 10^4$
5	$5,12 \times 10^4$	$4,70 \times 10^4$	$4,81 \times 10^4$	$7,30 \times 10^4$
Mean value	$(4,62 \pm 0,49) \times 10^4$	$(5,45 \pm 0,53) \times 10^4$	$(5,25 \pm 0,43) \times 10^4$	$(7,33 \pm 0,46) \times 10^4$

Comparing the mean values, in Tab. 2, it may be possible to find some differences between the materials. Nevertheless, it is not possible to state values ranges for each material. For instance, there is a clear difference between the hollow plastic ball and the steel ball, but, on the other hand, the mean values of the resin ball and the glass ball are quite similar.

One reason attributed to the unsatisfying area's analysis could be related to the mass difference between the balls of each material, for instance, the resin ball mass is greater than the glass and steel ball. Even that each ball was dropped from the same height, the resin ball presents greater kinetic energy, therefore, more energy dissipation, e.g. acoustic, it is expected. Hence, it is possible to conclude that the area value indicates which ball generate greater acoustic energy, and, not necessary exhibits a relation with the restitution coefficient.

#### 4.2. Curve Slope analysis

In Fig. 3, it can be observed that the inclination spectrum curves have a particular behavior for each material. Therefore, the slope's analysis offers an auspicious way to determine a pattern for each restitution coefficient. In this sense, it is established the inclination curve through a linear interpolation.

Figure 5 shows a Fourier spectrum curve, obtained from the resin ball, used to illustrate the methodology.

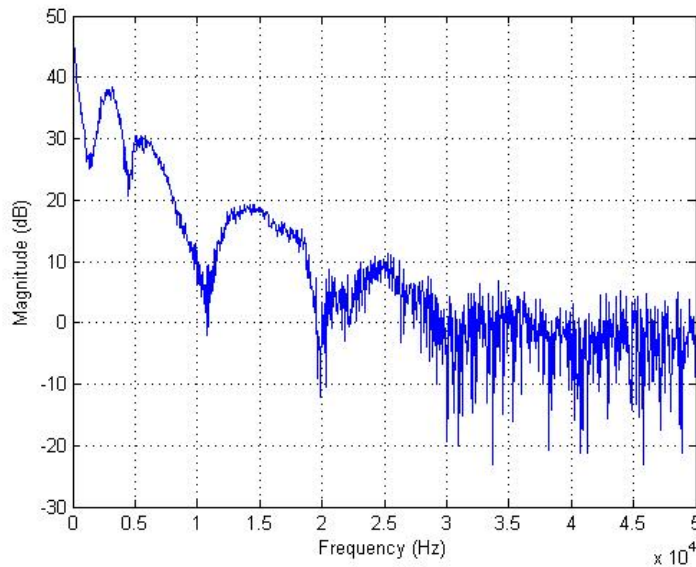

Figure 5: Fourier spectrum signal of the resin ball, 1024 samples.

As Fig. 5 shows, in order to normalize the signals it is not more considered the frequency axis, instead, the sample number is taken into account.

It must be mentioned that the higher frequency components, i.e. the noise measure effect, negatively influences to obtain a reliable linear interpolation, therefore a calculation slope value. In this sense, the last samples on Fig. 5, i.e. the higher frequencies components, are not considered on the assessment, Fig. 6.

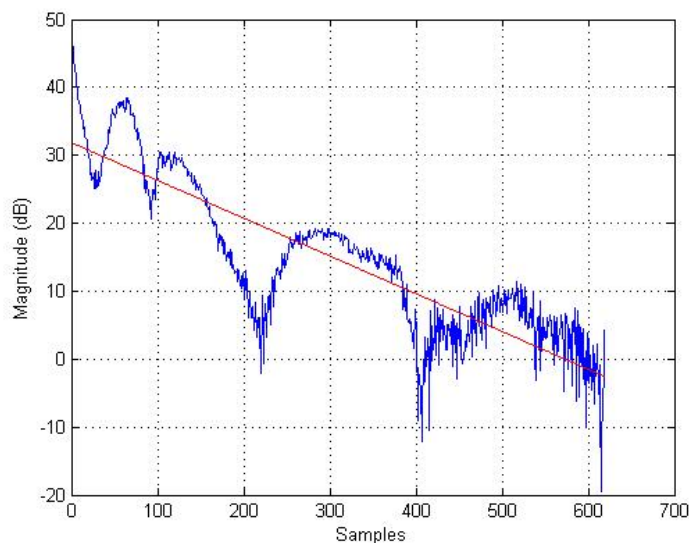

Figure 6: Fourier spectrum signal and inclination line estimated of the resin ball

The Tab. 3 presents the cut frequency, and the respectively sample number, defined for each impact signal. On the other hand, Tab. 4 presents the slope values obtained for each test.

Table 3. Cut frequency and its sample number.

Material Impact	Steel ball	Resin ball	Glass ball	Hollow plastic Ball
1	547 (26,7 kHz)	619 (30,2 kHz)	619 (30,2 kHz)	1024 (50,0 kHz)
2	464 (22,7 kHz)	550 (26,9 kHz)	744 (36,3 kHz)	1024 (50,0 kHz)
3	500 (24,4 kHz)	579 (28,3 kHz)	592 (28,9 kHz)	1024 (50,0 kHz)
4	650 (31,7 kHz)	609 (29,7 kHz)	636 (31,1 kHz)	817 (39,9 kHz)
5	568 (27,7 kHz)	572 (27,9 kHz)	748 (36,5 kHz)	892 (43,6 kHz)
Mean value	546 (26,7 kHz)	586 (28,6 kHz)	668 (32,6 kHz)	956 (46,7 kHz)

Table 4. Slope spectrum, mean value and standard deviation, of the spectrum signals.

Material Impact	Steel ball	Resin ball	Glass ball	Hollow plastic Ball
1	-0,0633	-0,0556	-0,0466	-0,0288
2	-0,0713	-0,0463	-0,0522	-0,0264
3	-0,0729	-0,0565	-0,0529	-0,0272
4	-0,0517	-0,0538	-0,0500	-0,0383
5	-0,0555	-0,0449	-0,0440	-0,0308
Mean value	-0,063 ± 0,019	-0,051 ± 0,011	-0,049 ± 0,008	-0,030 ± 0,010

However, the Tab. 5 presents the slope values obtained taking into account the same cut frequency, the average value, for each material, instead of considering a particular cut frequency for each test.

Table 5: Slope spectrum, average and standard deviation, considering the same cut frequency.

Material Impact	Steel ball	Resin ball	Glass ball	Hollow plastic Ball
1	-0,0634	-0,0550	-0,0452	-0,0303
2	-0,0629	-0,0515	-0,0548	-0,0277
3	-0,0671	-0,0542	-0,0536	-0,0285
4	-0,0618	-0,0533	-0,0496	-0,0356
5	-0,0560	-0,0501	-0,0453	-0,0295
Mean value	-0,062 ± 0,009	-0,053 ± 0,004	-0,050 ± 0,009	-0,030 ± 0,007

## 5. METHODOLOGY ASSESMENT

In order to validate the proposed methodology, based on the slope criteria, it was measured several impacts between the steel ball and the table, considering different ball's masses. The slope spectrum, calculated for each test, jointly its respectively mass are presented in Tab. 6.

Table 6. Slope spectrum, mean value and standard deviation, considering several steel ball's masses

Material Impact	Steel ball 1 (66,6g)	Steel ball 2 (28,1g)	Steel ball 3 (16,2g)	Steel ball 4 (3,52g)
1	-0,0634	-0,0504	-0,0439	-0,0277
2	-0,0629	-0,0340	-0,0434	-0,0235
3	-0,0671	-0,0519	-0,0464	-0,0263
4	-0,0618	-0,0474	-0,0547	-0,0247
5	-0,0560	-0,0540	-0,0426	-0,0169
Mean value	-0,062 ± 0,009	-0,048 ± 0,016	-0,046 ± 0,010	-0,024 ± 0,009

It can be observed, in Tab. 7, that the slope spectrum is directly proportional to the ball's mass, therefore, inversely proportional between the restitution coefficient and the ball's mass. In the particular case of steel balls, the smaller ones cool faster than the larger balls, providing different mass properties.

In order to verify the obtained result, it is calculated the restitution coefficient, Tab. 7, of each test from Tab. 6 based on the procedure described in section 3.

Table 7. Restitution coefficient, mean value and standard deviation, calculated on time, of steel ball 1 to 4.

Material Impact	Steel ball 1 (66,6g)	Steel ball 2 (28,1g)	Steel ball 3 (16,2g)	Steel ball 4 (3,52g)
1	0,675	0,753	0,780	0,840
2	0,670	0,756	0,830	0,800
3	0,670	0,747	0,780	0,808
4	0,678	0,769	0,761	0,820
5	0,659	0,753	0,793	0,828
Mean value	0,670 ± 0,015	0,756 ± 0,017	0,789 ± 0,052	0,819 ± 0,032

The restitution coefficients, presented in Tab. 7, show a correlation with the ball's mass, i.e. an inverse proportionality, consequently, it is corroborated the slope analysis presented. Furthermore, the slope criteria presents a direct relation with the restitution coefficient.

## 6. CONCLUSIONS

The first criteria used, presented a spectrum area of the resin ball greater than the steel and glass balls, nevertheless, its restitution coefficient is smaller than the glass ball and greater than the steel ball. Thus, the spectrum area criteria did not show a clear relation with the coefficient restitution, furthermore, it can be noted that the material and the mass can negatively influence on the analysis. In this sense, a restitution coefficient analysis based on the spectrum area, and considering the same material and mass may provide a better estimation.

On the other hand, the slope analysis presents a direct relation inversely proportional with the restitution coefficient. This analysis, based on the slope calculation, satisfactorily exhibits the relation with the restitution coefficient, considering several materials and mass of the balls.

## 7. ACKNOWLEDGMENT

The authors thank UFABC (Universidade Federal do ABC) for the support, and the first author thanks CNPq (Conselho Nacional de Desenvolvimento Científico e Tecnológico) for the financial support.

## 8. REFERENCES

- Andrade, J. A., Saotome, O., Améstegui, M. and, Romero J. F. A., "Otimização dos Parâmetros de Processo em Moinhos Semi Autógenos Mediante Técnicas de Processamento Digital de Sinais", apresentado na VII Conferência Internacional de Aplicações Industriais – INDUSCON 2006, Recife / PE, Abril / 2006
- Andrade, J. A., Améstegui, M. and, Romero J. F. A., "Algoritmo computacional para la medición del porcentaje de agregado grueso por abrasión e impacto en la Máquina de los Ángeles del IEM-UMSA", presentada en el 8° Congreso Iberoamericano de Ingeniería Mecánica – CIBIM8, Cusco – Peru, 2007.
- Azzoni, A. and De Freitas, M. H. "Experimental gained parameters, decisive for rock fall analysis. Rock Mechanics and Rock Engineering", 28(2): 111-124., 1995.
- Bernstein, A. D. "Listening to the coefficient of restitution", American Journal of Physics, 45(1): 41-43. 1977.
- Cavalcante, M.A.; Silva, E.; Prado, R. & Hagg, R. "O Estudo de Colisões Através do Som". Revista Brasileira de Ensino de Física, 24(2): 150-157. 2002
- Giani, G. P.; Giacomini, A.; Migliazza, M. & Segalini, A. "Experimental and Theoretical Studies to Improve Rock Fall Analysis and Protection Work Design". 2Rock Mechanics and Rock Engineering, 37 (5): 369-389. 2004.
- Stensgaard, I. and Lægsgaard, E., "Listening to the coefficient of restitution—revisited", Am. J. Phys. 69, 2001.
- Guercio, G. and Zanetti, V., "Determination of gravitational acceleration using a rubber ball", Am. J. Phys., 1987.
- Di Renzo, A., DiMaio, F. P., "Comparison of contact-force models for the simulation of collisions In DEM-based granular flow codes", Chemical Engineering Science, 2004
- Kuwabara, G. and Kono, K., "Restitution coefficient in a collision between two spheres", Japanese Journal of Applied Physics, 1987.
- Mangwandi, C., Cheong, Y.S., Adams, M. J., Hounslow, M.J. and Salman, A.D., "The coefficient of restitution of different representative types of granules", Chemical Engineering Science, 2007