

Multivariable Control Based on a Parameterized NMPC for Diesel Engines

André Murilo, andre.murilo@ufpe.br

Dept. of Mechanical Engineering, Federal University of Pernambuco, Av Arquitetura, Cidade Universitária 50740-550 Recife, Brazil

Mazen Alamir, mazen.alamir@gipsa-lab.fr

GIPSA-Lab/CNRS, Control Systems Dept., University of Grenoble, Domaine Universitaire 38400 Saint Martin d'Hères, France

Peter Ortner, peter.ortner@jku.at

Institute for Design and Control of Mechatronical Systems, JKU Linz Altenberger Straße 69,1-4040 Linz, Austria

Abstract. In this paper, a multivariable control strategy based on a parameterized Nonlinear Model Predictive Control (NMPC) approach is proposed for a Diesel engine air path. The aim is to control the level of pollutant emissions by coordinating the Exhaust Gas Recirculation (EGR) and the Variable Geometry Turbocharger (VGT) valves simultaneously. The main feature of the proposed controller lies in its compatibility with more elaborated nonlinear representations since it uses the model as a black box predictor. Some experimental results performed on a real world Diesel engine are presented in order to emphasize the efficiency of the controller.

Keywords: Parameterized NMPC, Multivariable Control, Black Box Predictor, Diesel Engine Air Path

1. INTRODUCTION

The study of Diesel engine passenger cars has become extremely important in recent years. These engines hold some important advantages such as low fuel consumption and high torque at low speed. This is particularly due to the combustion process that takes place on Diesel engines, based on Compression-Ignition (CI) instead of Spark-Ignition (SI) presented in standard gasoline engines (Heywood, 1998). Basically, in CI-engines, more torque can be delivered since only the air is compressed and ignites automatically when the fuel is injected. For this reason, the compression ratio of such engines is greater than SI-engines, which also improves some other important points such as efficiency and durability. However, one of the most drawbacks of Diesel engines concerns the pollutant emissions especially for Particulate Matter (PM) and Oxides of Nitrogen (NO_x). Reader can refer to Johnson (2001) and Flynn *et al.* (1999) for more details about the combustion process and the formation of emissions.

In order to deal with the levels of emissions, it is necessary to understand the Diesel engine air path as shown on Fig. 1. The arrows indicate the air flow inside the engine. Diesel engines are now equipped with two valves: the Exhaust Gas Recirculation (EGR) and the Variable Geometry Turbocharger (VGT) which affects directly the production of emissions according to Jacobs *et al.* (2003). The engine speed N and the fuel injection w_f define the operational point of the engine and must be considered as measurement disturbances. For the control of emissions, the Mass Air Flow (MAF) and the Manifold Air Pressure (MAP) are used as control outputs. The reason for not using the values of NO_x and PM is that there are no on-board sensors for the emissions in commercial vehicles. Therefore, the reference values for MAF and MAP are optimized in steady-state with respect to emissions and are mapped over the entire speed and fuel profiles (van Nieuwstadt *et al.*, 2000).

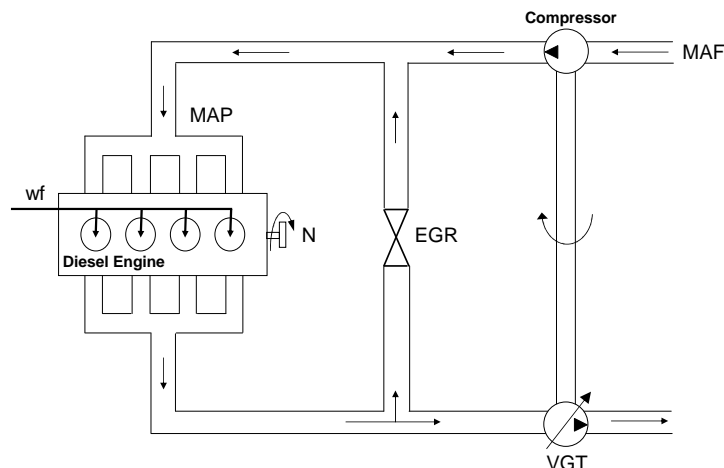

Figure 1. Simplified view of the Diesel engine air path

The combined effect of EGR and VGT together with a complex thermodynamical process make the Diesel engine air

path highly nonlinear and constrained. Then, an important number of contributions dealing with nonlinearities and constraints can be found in the literature concerning the Diesel engine control problem, such as Jankovic and Kolmanovsky (1998), Jung (2003), Plianos and Stobart (2007) and Chauvin *et al.* (2008). However, since Diesel engines are highly nonlinear and constrained systems, Nonlinear Model Predictive Control (NMPC) arises as an interesting candidate solution for such scenario. Predictive control is an advanced control methodology which uses explicitly the system model to predict the future evolution of the process (Mayne *et al.*, 2000). The basic idea of this control strategy consists in computing an optimal control sequence over a prediction horizon at each decision instant, by minimizing some given cost function expressing the control objective. The first control signal is scheduled to be applied to the system during the next sampling period and this optimization process is successively repeated at each sampling time. The prediction horizon keeps being shifted forward and for this reason predictive control is also called Receding Horizon Control (RHC). Figure 2 illustrates a simplified view of a predictive control scheme.

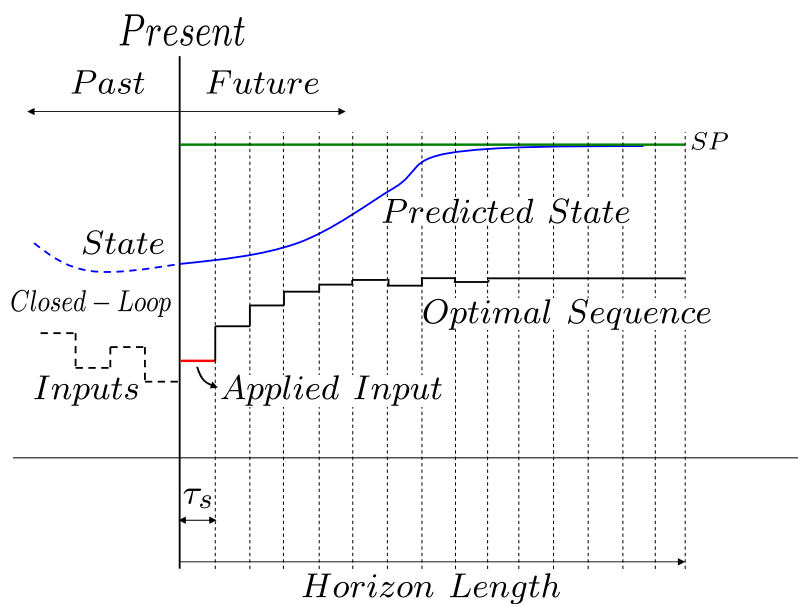

Figure 2. Schematic view of the predictive control strategy.

However, real-time implementation is the major drawback of NMPC-like approaches, since in most of the cases, finding the optimum solution may require a huge computation effort, leading to infeasible controllers. Model uncertainties may also represent a disadvantage for NMPC if they are not considered somewhere in the problem formulation.

Some predictive-like approaches have already been developed for the Diesel engine air path. In Ortner and del Re (2007), the explicit formulation (Bemporad *et al.*, 2002) is adopted, and some experimental results are presented. Nevertheless, since a huge look-up table is needed to address twelve local linear models, the effort to make all the off-line calculations limits the range of the control horizon which is set to 1. On the other hand, Ferreau *et al.* (2007) presents an active set based controller where on-line computations are performed. The approach is still based on linear models, but with an improvement on the control horizon, which has been set to 5. However, model uncertainties become the major drawback and authors mentioned that increasing the control horizon does not necessarily improve the results.

In this paper, a Multiple Inputs Multiple Outputs (MIMO) control strategy based on a parameterized NMPC is proposed for a real-world Diesel engine. The aim of the NMPC design is to track the set-points of the outputs MAF and MAP by acting on the control inputs EGR and VGT. The main point of the proposed NMPC solution is the fact that the optimal solution is completely independent of the nonlinear model structure being used, leading to a kind of black-box solution for the Diesel engine air path. Moreover, the constraints on the control inputs can be structurally taken into account in the formulation and the optimization routine is reduced to a low dimensional optimization problem enabling very short computation times.

This paper is organized as follows. First, the system model is presented in section 2. Then, section 3 formalizes the control design based on the parameterized NMPC approach and the optimization problem to be solved. In section 4, the experimental results obtained on the real world test bench are shown. Finally, section 5 ends the paper with the conclusion.

2. SYSTEM MODEL

Modeling Diesel engine dynamics is still a challenging problem. Generally, system identification based on Mean Value Model (MVM) method adopted by Christen *et al.* (2001) and Jung (2003) is one of the most common way to represent the system dynamics. Linear Parameter Varying (LPV) models derived from MVM is also an interesting way to model Diesel engines for control design (Wei, 2006). However, since Diesel engines show strong nonlinearities and constraints on EGR and VGT, standard multi-linear methods may be insufficient to cover the whole engine operational range and the use of more sophisticated models may be a crucial issue. As a result, this paper focuses on the control design methods that can cope with such models. The details about system identification are not in the scope of this work and reader can refer to the cited references for more informations.

A data based identification process realized in Ortner and del Re (2007) using the test bench of the Johannes Kepler University Linz, showed that the MAF and the MAP are basically influenced by the valves EGR and VGT, and by two measured disturbances, fuel injection w_f and engine speed N_e . In this paper, an eight-order nonlinear model identified in Ortner *et al.* (2009) from the Diesel engine test bench is adopted. This model has a similar affine structure as presented in Murilo *et al.* (2009), but in this case with the matrices A and C depending on the inputs and sampled at 50 ms, as follows:

$$x^+ = [A(u - u_c, w - w_c)]x + B_1[u - u_c] + B_2[w - w_c] \quad (1)$$

$$y = [C(u - u_c, w - w_c)]x + y_c + \varepsilon \quad (2)$$

$$\varepsilon^+ = \varepsilon \quad (3)$$

where $x \in \mathbb{R}^{n_x}$ is the state ($n_x = 8$), $y \in \mathbb{R}^{n_y}$ is the vector of measured and regulated output ($n_y = 2$) MAF and MAP, $w \in \mathbb{R}^{n_w}$ is the measured disturbance vector ($n_w = 2$) and $u \in \mathbb{R}^{n_u}$ is the control input ($n_u = 2$) representing the position (in %) of the valves EGR and VGT and u_c , y_c and w_c are the central values of input, output and disturbances respectively at the operation point used for the system identification. The variable ε represents the prediction error at the present instant k and deals with potential offset errors. The value of ε is updated at each sampling instant k according to:

$$\varepsilon(k) = \varepsilon(k-1) + k_i \cdot (y^p(k-1) - y^m(k))$$

where $y^p(k-1)$ and $y^m(k)$ are the predicted value under the previous state at instant $k-1$ and the measured output at instant k respectively, $\varepsilon(k-1)$ the previous value of the prediction error and $k_i \in \mathbb{R}^{n_y}$ the integrator gain. It is worth mentioning that the Diesel engine is open-loop stable, as shown in figure 3. In other words, the values of MAF and MAP asymptotically converge to some steady value that depend on the input values, EGR and VGT as well as fuel injection and engine speed. This important behavior of Diesel engines is more explored in the forthcoming sections.

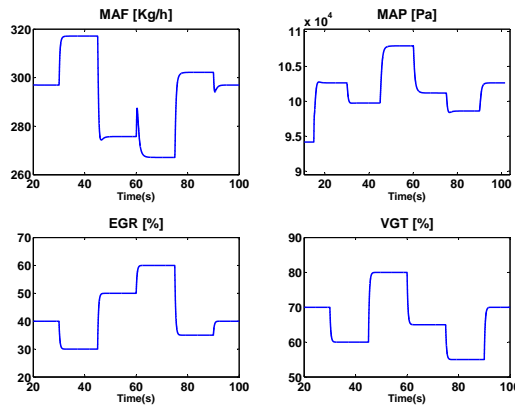

Figure 3. Open-loop behavior at $N_e=1800$ RPM and $w_f=20$ mg/cyl under a step sequence of EGR and VGT.

The control task consists in adjusting the VGT and EGR positions to track the required boost pressure MAP and the air mass flow rate MAF set-points. More formally, the control problem is to design a controller that forces y to track some desired set-point $y^d = [y_1^d, y_2^d]$ and the inputs u must satisfy the following set of constraints:

$$u \in [u_{min}, u_{max}] ; \quad u_{min} \in \mathbb{R}^{n_u} ; \quad u_{max} \in \mathbb{R}^{n_u} \quad (4)$$

$$\delta u \in [-\delta_{max}, +\delta_{max}] ; \quad \delta_{min} \in \mathbb{R}^{n_u} ; \quad \delta_{max} \in \mathbb{R}^{n_u} \quad (5)$$

where $\delta u = u(k+1) - u(k)$ and u_c is the central value around which the model identification is performed.

3. CONTROL DESIGN

In this section, a multivariable control strategy using a parameterized NMPC scheme is proposed based on the system model (1)-(3) as shown in the previous section. Here it is assumed that the whole state x can be estimated by means of an observer as presented in Murilo *et al.* (2009). This section is organized as follows. First, the computation of the stationary control is introduced. Then, some notions about the parameterized NMPC are presented and the control strategy is formalized. The section ends with the formulation of the optimization problem to be solved.

3.1 Steady State Computation

The first part of the control design consists in obtaining the stationary control given the measurement disturbances w and the desired outputs y^d . This is particularly due to the fact that the diesel engine is open loop stable. Then, the steady control can be obtained by solving a two-dimensional optimization problem as follows:

$$\begin{aligned} u^*(w, y^d) &:= \arg \min_{u_d \in [u_{min}, u_{max}]} \|y_c(u_d, w) - y^d\|^2 \\ y_c(u_d, w) &= C(u_d, w)[\mathbb{I}_{n_x} - A(u_d, w)]^{-1} \cdot [B \cdot u_d + G \cdot w] \end{aligned} \quad (6)$$

Once the steady control u^* is computed, the steady state x^* easily follows according to:

$$x^*(u^*, w) = [\mathbb{I}_{n_x} - A(u^*, w)]^{-1} \cdot [B \cdot u^* + G \cdot w] \quad (7)$$

As a matter of fact, the present formulation represents a generic way to find the stationary control (6). In fact, by keeping this simple optimization problem, one enforces the generic definition of the control structure. In the forthcoming topics, it is shown how this steady state pair is incorporated in the NMPC control design in order to derive a real-time compatible feedback scheme.

3.2 Parameterized NMPC

It is well-known that the real-time implementation is one of the main challenges concerning NMPC approaches, especially in the cases where optimization process must be solved within the sampling time. In order to meet the real-time requirements, many approaches have been developed in recent years (Bemporad *et al.*, 2002; Ferreau *et al.*, 2006; Ohtsuka, 2004; Diehl *et al.*, 2005; Zavala *et al.*, 2006). However, contrary to the cited references addressing the fully nonlinear solution, the parameterized approach adopted here (Alamir, 2006) enables a low dimensional on-line optimization problem to be derived that can be solved using simple and therefore potentially certified solution. This last feature is of great importance when talking about solutions that have to be adopted in industrial large production units context. Indeed, in such context, implementing dedicated algorithms based on sparse or large decision variable like optimizers, may be incompatible with industrial certification requirements.

The control parametrization approach amounts to choose the candidate piecewise open loop control profiles within a class of control profiles that are defined by a low dimensional vector of parameters $p \in \mathbb{P}$. More precisely, this amounts to define a map $\mathcal{U}_{pwc} : \mathbb{P} \times \mathbb{R}^{n_x} \rightarrow \mathbb{U}^{N_p}$, where N_p is the prediction horizon, such that the piecewise constant control sequence corresponding to the parameter p is given by:

$$\mathbf{u} = \mathcal{U}_{pwc}(p, x(k))$$

where p is the parameter to optimize at each decision instant k , and $x(k)$ the current value of the state. The optimal parameter \hat{p} is computed by solving the following optimal control problem in the decision variable p as follows:

$$\hat{p} := \arg \min_{p \in \mathbb{P}} [J(p, x(k))] \quad \text{under} \quad C(p, x(k)) \leq 0$$

where $J(\cdot)$ is the cost function to be minimized and $C(p, x(k))$ are the constraints to be respected and \hat{p} the optimal parameter vector. Once the optimal parameter \hat{p} is obtained, the optimal control sequence $\tilde{\mathbf{u}}$ follows according to:

$$\tilde{\mathbf{u}} = \mathcal{U}_{pwc}(\hat{p}, x(k)) = [u^{(1)}(\hat{p}, x(k)) \quad \dots \quad u^{(N_p)}(\hat{p}, x(k))]$$

from which only the first element of $\tilde{\mathbf{u}}$ is scheduled to be applied during the sampling period $[k + 1, k + 2]$, namely:

$$u^{opt}(k+1) = u^{(1)}(\hat{p}, x(k))$$

During the next sampling period $[k+1, k+2]$ the same steps described above are executed again, and the next optimal control namely $u^{opt}(k+2)$ is provided. This clearly define an implicit feedback strategy.

3.3 Parameterized NMPC Formulation for Diesel Engines

Section 3.1 showed that a static gain map can be obtained thanks to the system model behavior, which is open-loop stable. Then, supplementaries degrees of freedom need to be introduced in order to deal with the transients of the output tracking error. As a result, the parameterized NMPC scheme consists in the steady control computed according to (6) together with a temporal parametrization of the future control sequence. In order to do this, the exponential parameterized structure (Alamir, 2006) of the control sequence is proposed:

$$\mathbf{u}(i\tau_s + t) = Sat_{u_{min}}^{u_{max}} \left(u^* + \alpha_1 \cdot e^{-\lambda \cdot i \cdot \tau_s} + \alpha_2 \cdot e^{-q \cdot \lambda \cdot i \cdot \tau_s} \right) \quad \text{for } t \in [(k-1)\tau_s, k\tau_s[\quad (8)$$

where $i \in \{0, \dots, N_p - 1\}$, τ_s is the sampling period, $\lambda > 0$, $q \in \mathbb{N}$ are tuning parameters, $\alpha_1, \alpha_2 \in \mathbb{R}^{n_u}$ are the coefficients to be determined and they are more explained below and Sat is a saturation map $Sat : \mathbb{R}^{n_u} \rightarrow \mathbb{R}^{n_u}$ in order to address the constraints on inputs according to (5). Then, given the value of u^* computed according to (6) and the previous value of the control input $u(k-1)$ scheduled in $[k-1, k]$ the following set of equations can be derived from (8):

$$u^* + \alpha_1 + \alpha_2 = u(k-1) \quad (9)$$

$$\alpha_1 \cdot (e^{-\lambda \cdot \tau_s} - 1) + \alpha_2 \cdot (e^{-q \cdot \lambda \cdot \tau_s} - 1) = p \cdot \delta_{max} \quad ; \quad p \in [-1, +1]^2 \quad (10)$$

where (9) guarantees continuity of the control profiles while (10) simply states that the difference between two successive applied control does not exceed a fraction $p \in [-1, +1]^2$ of some maximal allowable values $\delta_{max} \in \mathbb{R}^{n_u}$ according to (5). Then, the parameters α_1 and α_2 can be directly determined by solving the following linear system:

$$\begin{pmatrix} \alpha_1^{u_1}(p) \\ \alpha_2^{u_1}(p) \\ \alpha_1^{u_2}(p) \\ \alpha_2^{u_2}(p) \end{pmatrix} = \begin{pmatrix} 1 & 1 & 0 & 0 \\ 0 & 0 & 1 & 1 \\ e^{-\lambda \cdot \tau_s} - 1 & e^{-q \cdot \lambda \cdot \tau_s} - 1 & 0 & 0 \\ 0 & 0 & e^{-\lambda \cdot \tau_s} - 1 & e^{-q \cdot \lambda \cdot \tau_s} - 1 \end{pmatrix}^{-1} \cdot \begin{pmatrix} u_1(k-1) - u_1^* \\ u_2(k-1) - u_2^* \\ p_1 \delta_{max}^1 \\ p_2 \delta_{max}^2 \end{pmatrix}$$

where the notation $\alpha_1 = [\alpha_1^{u_1}; \alpha_1^{u_2}]$ and $\alpha_2 = [\alpha_2^{u_1}; \alpha_2^{u_2}]$ is used. Injecting this in the equation of the control sequence (8) leads to:

$$\mathbf{u}(i\tau_s + t, p) = Sat_{u_{min}}^{u_{max}} \left(u^* + \alpha_1(p) \cdot e^{-\lambda \cdot i \cdot \tau_s} + \alpha_2(p) \cdot e^{-q \cdot \lambda \cdot i \cdot \tau_s} \right) \quad (11)$$

The expression (11) clearly shows how the control profile depends on the parameter vector p introduced in (10). Therefore, the next step consists in defining an optimization problem to obtain the best set of parameters p .

3.4 Optimization Problem

The optimization problem to be solved must considerer two important points to define the cost function J . The first one is the tracking error $y - y^d$ since the problem to be solved is the tracking of MAF and MAP. The second one is the terminal cost on the state which means that the cost function must penalize the final state at the end of the prediction horizon in order to address the stability issue. Therefore, one can define the following optimization problem:

$$\hat{p} := arg \min_{p \in \mathbb{P}} \left[\rho_x \cdot \|X(N_p, x(k), p) - x^*(u^*, w)\| + \sum_{i=0}^{N_p-1} \|Y(i, x(k), p) - Y_f(i, y^d)\|^2 \right] \quad (12)$$

where $Y(i, x(k), p)$ is the output prediction based on the system equations (1)-(3) under the open loop control profile defined by p over $[0, k + N_p - 1]$ and starting from the current state $x(k)$, $X(N_p, x(k), p)$ the state prediction at the end of the prediction horizon used to define the terminal cost, $x^*(u^*, w)$ the stationary state computed according to (7), $\rho_x > 0$

is some weighting coefficient used to enforce the constraint on the final state. Finally $Y_f(i, y^d)$ is the filtered version of the set-point trajectory enabling to decouple the response time from overshoots:

$$Y_f(i, y^d) = y^d + e^{-3\tau_s \cdot i/t_r} \cdot [y(k) - y^d]$$

where t_r is the desired response time of the closed loop system. Figure 4 shows a simple example showing the evolution of two parameters p_1 and p_2 and the tracking of the outputs MAF and MAP. In figure 5 three particular instants $k_i, i \in \{1, 2, 3\}$ were chosen to illustrate the shape of the cost function $J(\cdot, x_{k_i})$ as a function of the two decision variables p_1 and p_2 . Note the trajectory of the optimum value \hat{p} and the descent of the cost function from left to right showing the efficiency of the proposed optimization problem. It is worth mentioning that by the definition of the parametrization, when p is saturated at -1 or 1 , the constraint δ_{max} on the rate of change of the control input is active. On the other hand in the steady state, the best set of parameters is $p = 0$ since $u(k) = u(k - 1)$.

It is important to emphasize that the complexity of the optimization task heavily depends on the problem formulation, and hence, the control parametrization. This can be clearly seen in figure 5 which shows how the low dimensional control parametrization proposed for this system leads to a well posed optimization problem.

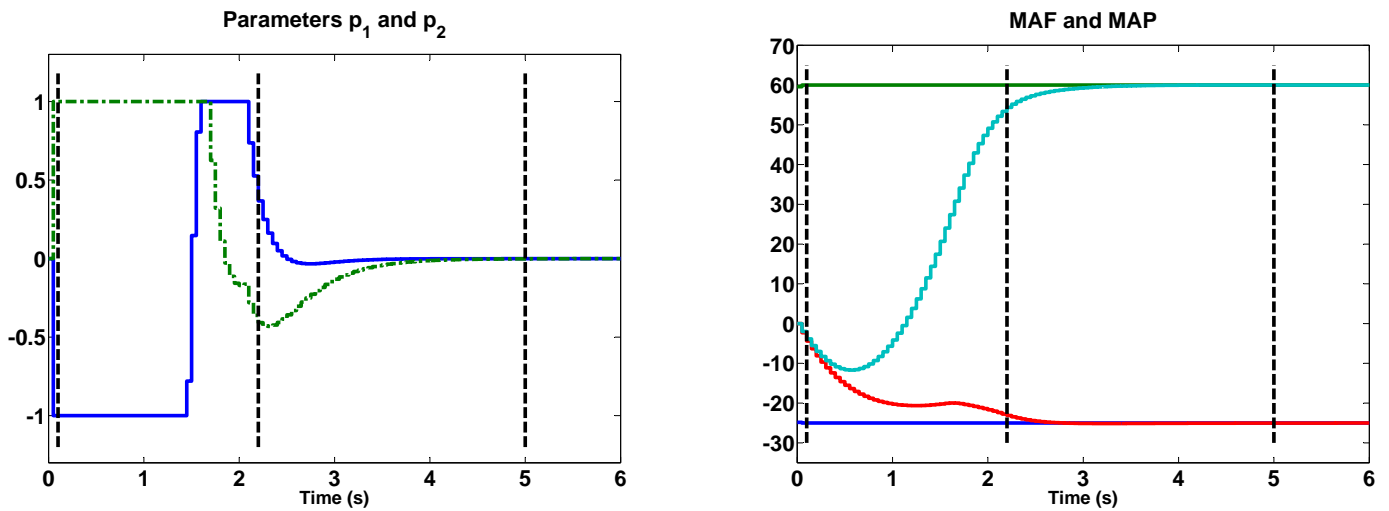

Figure 4. Simulation results showing the evolution of p_1 and p_2 and the tracking of the set-points $y^d = [60; -25]$. The instants $t = 0.1s, t = 2.2s$ and $t = 5s$ have been used to illustrate the shape of cost function in Figure 5.

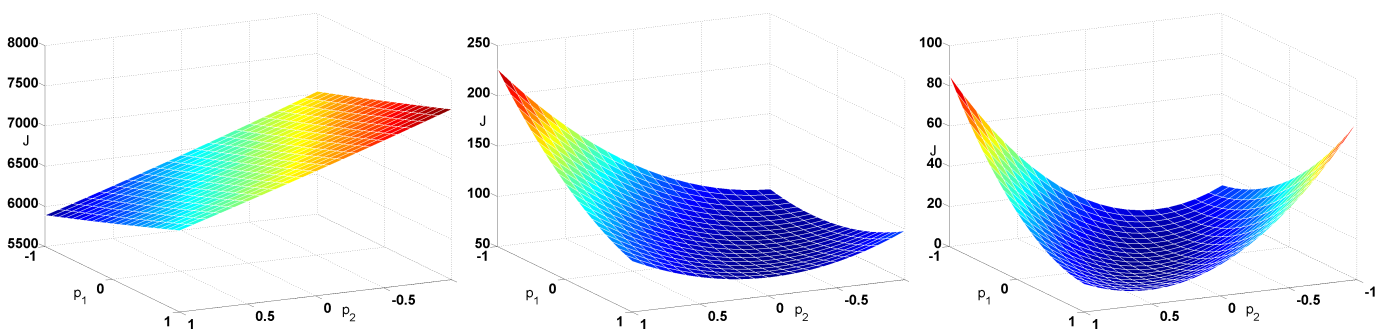

Figure 5. The shape of the cost function $J(\cdot, x(k_i))$ for the three particular instants depicted on figure 4 ($t_1 = 0.1 s$ (left), $t_2 = 2.2 s$ (center), $t_3 = 5.0 s$ (right)).

As far as the optimizer is concerned, classical solvers like Powell's method and simplex were tested, and the obtained results were quite positive and very similar. However, a particular Sequential Quadratic Programming (SQP) routine was developed for simulations and also used for experimental validation. For the sake of completeness, in this paper a brief presentation of the algorithm is provided and a detailed description can be found in Murilo (2009). Basically, the algorithm consists in two main parts: Scalar SQP and Gradient Procedures. For the first one, the algorithm performs scalar SQP's

on each component p_i which corresponds to three iterations, namely $iter$, to obtain a quadratic approximation. Then, a candidate cost function is evaluated and compared with the current value of J , leading to an adaptation of a trust region, representing by the parameter d_p , depending on the success or not of this operation. After each complete cycle of scalar SQP's over the n_p components (which in this case, $n_p = 2$), the results are used for the second part, the Gradient Procedure, to construct an approximation of the gradient $grad$ along which potentially successful steps are attempted. Again, a trust region, now represented by α_g , is updated along the gradient. The whole algorithm stops when the upper bound number of function evaluations n_{fe} is reached by the number of iterations and the best value of p_{opt} that minimizes the cost function is returned. This results in the following algorithm:

Algorithm 1 Main Program : Compute a optimal value p_{opt}

```

Initialization:  $d_p \leftarrow d_p^0; \alpha_g \leftarrow \alpha_g^0; p \leftarrow p^0$ 
 $J \leftarrow$  Cost Function( $p$ )
 $iter \leftarrow 1$ 
while  $iter \leq n_{fe}$  do
  for  $i = 1$  to  $n_p$  do
     $[p_i, d_{p_i}, J, grad_i] \leftarrow$  Scalar SQP Procedure( $p, d_{p_i}, J$ )
     $iter \leftarrow iter + 3$ 
     $i \leftarrow i + 1$ 
  end for
   $Sucess_{Gradient} \leftarrow 1$ 
  while  $Sucess_{Gradient} = 1$  and  $iter \leq n_{fe}$  do
     $[p, Sucess_{Gradient}] \leftarrow$  Gradient Procedure( $p, grad, \alpha_g, J$ )
     $iter \leftarrow iter + 1$ 
  end while
end while
 $p_{opt} \leftarrow p$ 
Return( $p_{opt}$ )
    
```

As a result, the proposed routine yields an optimization algorithm that uses the model as a black-box simulator and is therefore easily re-usable if a more sophisticated and faithful process model is made available.

4. EXPERIMENTAL VALIDATION

In this section, some experimental results are presented in order to show the efficiency of the proposed controller. The experiments were performed at Johannes Kepler University Linz on a Diesel engine fulfilling the EU4 emission standard. The test bench is controlled by the Engine Control Unit (ECU) and an AVL dynamometer is used to simulate the load on the engine shaft. A d-Space Autobox running at 480 MHz linked to Matlab was used as real-time platform. The programs were developed in C language using S-functions of Matlab. The sampling time was set to 50 ms and the number of function evaluations n_{fe} to 30.

The experiments were divided into two parts. The first one consists in a manual setting of the set points of MAF and MAP by imposing a step sequence trajectory for both variables. The second one uses the non-urban part of the New European Driving Cycle (NEDC) to generate the set-points. The NEDC is supposed to represent the typical usage of a car in Europe and is used to assess the emission levels of car engines. Table 1 shows the parameters used in the experiments. Since the model was identified around a central value, MAF and MAP are represented by their difference with respect to this central value.

Table 1. Parameters used in experiments

Parameter	Value	Parameter	Value
τ_s	0.05s	δ_{max}	$[1;1]\%/\tau_s$
N_p	30	ρ_x	1000
λ	1	q_{max}	30
q	5	t_r	$3 \cdot \tau_s / q \cdot \lambda$

4.1 Successive Steps Sequence

Figure 6 shows the ECU's response for a step sequence (left) and the parameterized NMPC approach (right). The ECU's control design is based on a Single Input Single Output (SISO) controller, with feedback control for MAF and feed-forward for MAP. As shown in this figure, the MAF is highly weighted by ECU while the MAP's tracking is viewed as a secondary task. On the other hand, the NMPC approach shows a more regular tracking performance and the controller

is able to track both variables, which are equally weighted. Note that the constraints on the inputs are correctly handled. The offset errors are eliminated by means of the integrator term introduced in (4). Some other scenarios were performed by changing the parameters of table 1 without significant improvement on the results.

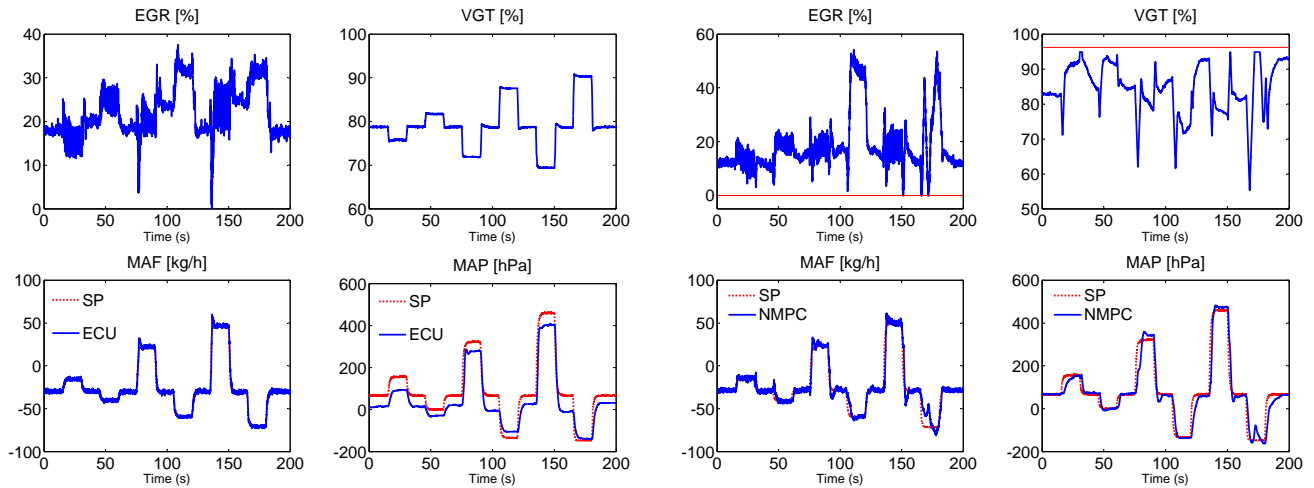

Figure 6. ECU's response (left) and the parameterized NMPC scheme (right) for a step sequence.

4.2 European NEDC Sequence

The second part of the experiment consists in testing the present controller under the high-speed part of the NEDC. The figure 7 shows the ECU's tracking performance (left) and the parameterized NMPC scheme (right). For the first one, the MAF is correctly tracked until $t = 210$, where the engine speed exceeds the 2100 RPM. The same deterioration at high speed is also noted on the MAP's tracking performance. For the second one, the NMPC approach clearly shows a more regular quality in the tracking performance for both variables comparing to the ECU's, except in the last part at low speed and fuel, where model uncertainties are extremely high. Moreover, the slow dynamics of the engine speed profile of the NEDC does not generate abrupt set-point variations, and naturally filters oscillations and overshoots.

On the other hand, this solution seems to be a little sensitive to the fast set-point variations, since the sampling period is not short enough to compensate model uncertainties. Moreover, it is worth mentioning that models for control design, especially for Diesel engines, are usually identified in order to match to some feasible or existing control scheme, leading to the trade-off between model complexity and control feasibility. That is the main feature of the proposed controller, which shows that the present NMPC approach can be entirely decoupled from the model structure.

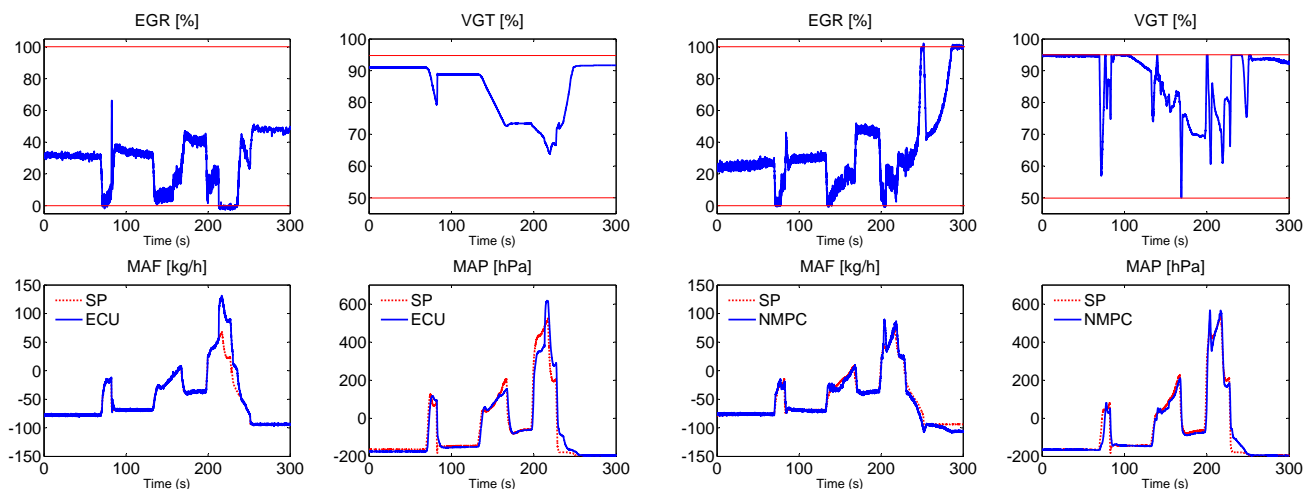

Figure 7. Experimental results showing the ECU's response (left) and the parameterized NMPC scheme (right) under the extra-urban part of the NEDC.

5. CONCLUSION

In this paper, a MIMO controller based on the parameterized NMPC approach was proposed for the Diesel engine air path. It was shown that the presented solution can be used as a general NMPC framework and can deal with more sophisticated and fully nonlinear models. Some experimental results performed on a real world Diesel engine showed that the parameterized NMPC is real-time implementable and the constraints on the inputs are structurally respected. The tracking performance was compared with the existing ECU and the obtained results were very satisfactory and incite further investigations of the proposed controller on a fully nonlinear model representing the whole thermodynamical behavior of the engine.

6. REFERENCES

- Alamir, M., 2006. *Stabilization of Nonlinear System Using Receding-Horizon Control Schemes: A parametrized approach for Fast Systems*. Lecture Notes in Control and Information Science. Springer, London, ISBN 1-84628-470-8.
- Bemporad, A., Morari, M., Dua, V. and Pistikopoulos, E.N., 2002. "The explicit linear quadratic regulator for constrained systems". *Automatica*, Vol. 38, pp. 3–20.
- Chauvin, J., Corde, G., Petit, N. and Rouchon, P., 2008. "Motion planning for experimental airpath control of a diesel homogeneous charge-compression ignition engine". *Control Engineering Practice*, Vol. 16, pp. 1081–1091.
- Christen, U., Vantine, K.J. and Collings, N., 2001. "Event-based mean-value modeling of DI Diesel engines for controller design". *SAE, Paper 2001-01-1242*.
- Diehl, M., Bock, H.G. and Schloöder, J.P., 2005. "A real-time iteration scheme for nonlinear optimization in optimal feedback control". *Siam Journal on Control and Optimization*, Vol. 43, pp. 1714–1736.
- Ferreau, H.J., Bock, H.G. and Diehl, M., 2006. "An online active set strategy for fast parametric quadratic programming in MPC applications". *Proceedings of the IFAC Workshop on Nonlinear Model Predictive Control for Fast Systems*.
- Ferreau, H.J., Ortner, P., Langthaler, P., del Re, L. and Diehl, M., 2007. "Predictive control of a real-world Diesel engine using an extended online active set strategy". *Annual Reviews in Control*, Vol. 31, pp. 293–301.
- Flynn, P.F., Durrett, R.P., Hunter, G.L., zur Loye, A.O., Akinyemi, O.C., Dec, J.E. and K. Westbrook, C., 1999. "Diesel Combustion: An Integrated View Combining Laser Diagnostics, Chemical Kinetics, and Empirical Validation". *SAE, Paper 1999-01-0509*.
- Heywood, J.B., 1998. "Internal combustion engines fundamentals". *McGraw-Hill*.
- Jacobs, T., Assanis, D. and Filipi, Z., 2003. "The impact of exhaust gas recirculation on performance and emissions of a heavy-duty diesel engine". *SAE, Paper 2003-01-1068*.
- Jankovic, M. and Kolmanovsky, I., 1998. "Robust nonlinear controller for turbocharged Diesel engines". *Proceedings of the American Control Conference, Philadelphia*.
- Johnson, T.V., 2001. "Diesel emission control in review". *SAE, Paper 2001-01-0184*.
- Jung, M., 2003. "Mean-value modelling and robust control of the airpath of a turbocharged Diesel engine". *Ph.D. dissertation, University of Cambridge*.
- Mayne, D.Q., Rawlings, J.B., Rao, C.V. and Scokaert, P.O.M., 2000. "Constrained model predictive control: Stability and optimality". *Automatica*, Vol. 36, No. 6, pp. 789–814.
- Murilo, A., 2009. "Contributions on Nonlinear Model Predictive Control for Fast Systems". *Ph.D. dissertation, University of Grenoble*.
- Murilo, A., Alamir, M. and Ortner, P., 2009. "Fast NMPC Scheme for a Diesel Engine Air Path". *Proceedings of the European Control Conference (ECC'09), Budapest*.
- Ohtsuka, T., 2004. "A continuation/gmres method for fast computation of nonlinear receding-horizon control". *Automatica*, Vol. 40, pp. 563–574.
- Ortner, P., Bergmann, R., Ferreau, H.J. and del Re, L., 2009. "Nonlinear Model Predictive Control of a Diesel Engine Airpath". *IFAC Workshop on Control Applications of Optimisation, Jyväskylä*.
- Ortner, P. and del Re, L., 2007. "Predictive control of a Diesel engine air path". *IEEE Transactions on Control Systems Technology*, Vol. 15, No. 3, pp. 449–456.
- Plianos, A. and Stobart, R., 2007. "Dynamic feedback linearization of Diesel engines with intake variable valve actuation". *IEEE Transactions on Control Systems Technology*, pp. 455–460.
- van Nieuwstadt, M.J., Kolmanovsky, I.V. and Moraal, P.E., 2000. "Coordinated EGR-VGT control for Diesel engines: An experimental comparison". *SAE, Paper 2000-01-0266*.
- Wei, X., 2006. "Advanced LPV techniques for Diesel engines". *Ph.D. dissertation, Johannes Kepler University*.
- Zavala, V.M., Laird, C.D. and Biegler, L.T., 2006. "Fast solvers and rigorous models: can both be accommodated in NMPC?" *Proceedings of the IFAC Workshop on Nonlinear Model Predictive Control for Fast Systems*.