

DEVELOPMENT OF A HYBRID SYSTEM FOR RISK MANAGEMENT IN THE PIPELINE ON-SHORE

Koje Daniel Vasconcelos Mishina, koje@ct.ufpb.br

João Bosco de Aquino Silva, jbosco@ct.ufpb.br

Federal University of Paraíba, City University - João Pessoa - PB - Brazil - CEP - 58051-900

José Felício da Silva, jfeliciodasilva@yahoo.com.br

Universidade de Brasília, UNB Faculty Gama – FGA, Special Area I, Central Sector, Brasília - DF - Brazil – CEP - 72405-610

Marcelo Cavalcanti Rodrigues, celo_cr@yahoo.com.br

Federal University of Paraíba, City University - João Pessoa - PB - Brazil - CEP - 58051-900

José Carlos de Lima Júnior, limajrcarlos@hotmail.com

Federal University of Paraíba, City University - João Pessoa - PB - Brazil - CEP - 58051-900

Abel Cavalcante de Lima Filho, abel@les.ufpb.br

Federal University of Paraíba, City University - João Pessoa - PB - Brazil - CEP - 58051-900

***Abstract.** This paper proposes the development of a hybrid system for managing the risk of leaks in pipelines onshore and offshore from the phenomenon of corrosion. This model is based on the methodology of Risk Based Inspection (RBI) and the theory of fuzzy logic for its evaluation. In this context, we developed a risk matrix pattern specific to the transport of oil and its derivatives. This risk matrix considers the likelihood of the spill (prevention variables and attributes associated with the phenomenon of corrosion as well as the operational conditions under which the pipeline is submitted) and the consequences associated with a possible leak (human factors, operational and environmental). This project stemmed from a Doctoral Dissertation entitled "Risk Assessment in corroded pipes through the fuzzy logic according to RBI methodology" to validate the proposed system using actual data of three pipelines that operate in the Petrobras oil transfer in a Exploration and Production Unit. From the results obtained there was consistency in the levels of risk found in relation to what would be expected in practice. This shows that the use of the RBI methodology and the theory of fuzzy logic, can be employed together as an alternative technique very effective in managing risk in corroded pipelines. The objective of this project is to not only manage land pipelines (onshore), but increasing risk management for oil offshore (not land). And next step is to develop a low-cost software compared to commercial software (imported) and that in most cases does not reflect the actual situations of our operation and transportation. The development of this software will guarantee to keep the risk in transporting hydrocarbons to acceptable standards worldwide, increasing reliability and availability of this type of transportation that has grown significantly in Brazil.*

***Keywords:** pipeline; risk based inspection; fuzzy logic.*

1. INTRODUCTION

The structure of supplying of oil and derivatives establish connection through some modalities of transport three distinct points: sources of production, refineries and the centers of consumption. In the factor security, the comparative ducts to other ways of transport have presented resulted more satisfactory, as much in the supplying of the refineries as in the supplements of the great centers of derivatives. In function of the basic characteristic of draining of hydrocarbons, the ducts operate under high pressures and can be managed by diverse companies. Although sophisticated systems of control and supervision of the installations to exist, what it reflects in low a tax of compared accidents if with other ways of transport. However, the accidents have called public attention for the involved consequences.

Normally, the ducts operate in inhabited regions, or places that present high ambient sensitivity, such as, sources of potable water supply, sources, etc. The transport in ducts displays has sectors varied of the society and to the environment, an intrinsic risk of the transport and distribution of the oil and its derivatives. In function of this context, it is necessary that the operators have understanding of the consequences that the accidents can generate, with the objective to establish levels of acceptable risks. One another factor that comes to contribute with the necessity to establish levels of tolerable risks, the requirement how much to the question of the ambient preservation says respect. That is, the ambient agencies of fiscalization, as well as the Public prosecution service and National Agency of Petroleum (ANP) are each time more rigorous in the application of fines and a program aiming at behavior adequacy, the objective is to keep its activity inside of a standard of acceptable security world-wide.

There are several mechanisms of damage associated with transportation of oil and its derivatives, depending on the actual operating conditions and environmental work. However, corrosion is the only mechanism of damage that occurs naturally from the continuous operation of the pipeline. The origin of the oil and its derivatives are resulted of a mixture of hydro-carbons that contains some contaminations gases as: CO₂ (Carbon Dioxide), H₂S (Sulfidric Acid), beyond water vapor. These elements are the potential greater for the occurrence of the corrosive process. It is important to know to deal with these contaminations, aiming at to minimize its corrosive action. The frequent draining in specific points throughout the duct for withdrawal of the formed condensed one in function of the temperature fall is one of the necessary measures (Cunha, 2001). The experience has shown that the control of the corrosion is one of the biggest challenges in the transport through ducts. The corrosion consists of the deterioration of the materials for the chemical or electrochemical action of the way, being able to be or not associated the mechanical efforts. With exception of some usual types of corrosion, as normally found in a metallic duct, it is basically, an electrochemical process by its very nature. The corrosive processes of electrochemical nature present identical mechanisms because always they will be constituted by anodic and cathode areas, between which circulate an electron chain and a chain of ions. However, the loss of mass and the way of attack on the material happen of some forms. The types of corrosion more normally found in ducts used in the transport of hydro-carbons are: Corrosion Uniform, Corrosion for Pits, Corrosion for Distinguishing Concentration, Galvanic Corrosion, and Corrosion associated with the fluid draining. The knowledge of the principle of each mechanism of damage, its form of propagation and the methods of control is indispensable so that if it has an efficient control on the same ones. To control the corrosion means to control the reaction of the metal with its half one, of form that the physical and mechanical properties of the metal are preserved during its time of useful life (Pimenta, 2001). The control of the corrosion effective includes all the prevention forms, being able to be classified in four great groups: Control in the period of training of project, Control for the influence in the metal, Control for the influence in the way and Control with covering (Silva, 2001).

2. METHODOLOGY OF THE RISK BASED INSPECTION (RBI) AND THEORY OF THE LOGIC FUZZY APPLIED IN CORRODED DUCTS

The risk concept comes sufficiently being used in the equipment area and is based on the coupling of the variable: probability and consequence of failure. According to API STD 1160 (Managing System Integrity for Hazardous Liquid/API-2001), the risk for a duct is given in function of the probability of an event or a condition to lead to the occurrence of an emptying. Pipelines are projected to take care of the requirements of project previously established. However, in service, the pipelines are displayed more severe operational and ambient the conditions, as increase in the pressure and/or operating temperature, not suitable ambient conditions with the project; factors as these compromise the structure considerable increasing the risk level (Mishina, K.D.V., et al., 2002). The company operators who carry harmful products to the nature must establish levels of tolerable operational risks. In case that the risk is above of the tolerable one, injunctions must be implemented in the direction to reduce the risk the acceptable standards. Based in this context the American Petroleum Institute a document, being published elaborated in May of 2000, Base Resource Document - API-581 - Risk Based Inspection. This document if relates to the established inspection at risk and has as objective to present a methodology for the priority of the risk associated with the equipment and industrial units, establishing a normalization of concepts of basic importance for the area of risk based on inspection (Eckstein, C.B., et al, 2001).

The methodology of the IBR quantifies the risk of one definitive equipment as being function of the product between the probability and the consequences of the imperfection, as the Eq. (1). (Donato, G.V.P., 2001).

$$R = P \times C \quad (1)$$

Where “R” is the Risk, “P” is the measure of the Probability of occurrence of leaks and “C” represents the Consequences associates to the leaks. With the objective to establish acceptable levels of risk in the transport in pipelines on-shore of hydro-carbons, a risk matrix was developed (Fig. 1). This Matrix has as principle the Matrix of Risk Standard of document API RP 581 (2000), with some adaptations aiming at to take care of satisfactory form the transport of hydro-carbons. The same one is formed by the combination of the categories of probability in the vertical axis and the consequences in the horizontal axis, generating a matrix 5x5, as Fig. (1).

Matrix of Risk		Class of Consequence				
		1	2	3	4	5
Class of Probability	5	5	10	15	20	25
	4	4	8	12	16	20
	3	3	6	9	12	15
	2	2	4	6	8	10
	1	1	2	3	4	5

Figure 1. Matrix of Risk for evaluation of corroded ducts.

The Class of Probability of failure is given by the addition enters the index of corrosion (IC) and the resultant internal shipment of the relation between the pressures of operation and project (β), as Tab. (1).

Table 1. Category of the Classroom of Probability

Criterion	Interpretation	CP
Index of Corrosion (IC)	Index of Corrosion much raised / $IC > 70\%$ of the thickness of the wall of the duct.	5
Relation between Pressures Operation and Project ($\beta = P_0/P_P$)	Level of the very high relation / $\beta > 80\%$.	
Index of Corrosion (IC)	High index of Corrosion / $50\% < IC \leq 70\%$ of the thickness of the wall of the duct.	4
Relation between Pressures Operation and Project ($\beta = P_0/P_P$)	Level of the high relation / $70\% < \beta \leq 80\%$.	
Index of Corrosion (IC)	Average index of Corrosion / $20\% < IC \leq 50\%$ of the thickness of the wall of the duct.	3
Relation between Pressures Operation and Project ($\beta = P_0/P_P$)	Average index of relation/ $50\% < \beta \leq 70\%$.	
Index of Corrosion (IC)	Low index of Corrosion / $10\% < IC \leq 20\%$ of the thickness of the wall of the duct.	2
Relation between Pressures Operation and Project ($\beta = P_0/P_P$)	Low level of relation / $20\% < \beta \leq 50\%$.	
Index of Corrosion (IC)	Very low level of Corrosion / $IC \leq 10\%$ of the thickness of the wall of the duct.	1
Relation between Pressures Operation and Project ($\beta = P_0/P_P$)	Very low level of relation/ $\beta \leq 20\%$.	

CP – Class de Probability

The consequences of the leak are directly related to the amount of fluid that could leak in the occurrence of a possible leak (Silva, et al., 2005). In turn, the amount of leaked product depends on the flow and the response of the supervisory system to detect leaks. In pipe-lines, the use of systems for detention of leaks is a practice that has been applied in the majority of the operators, what an extenuating factor becomes.

The Class of Consequences (CC) was developed in accordance with the rules that define the impacts of the failures with regard to the Staff (losses of lives human beings), environment (ambient contamination) and to the operation of the system (losses of production), in accordance with the Tab. (2), that is, will be evaluated the causes associates to the three mentioned criteria, taking in consideration the region where it finds the stretch in study (Mishina, K. D. V., 2001).

Table 2. Category of the Classroom of Consequence

Criterion	Interpretation	CC
Personal	Catastrophic Danger for the staff/risk of many deaths	5
Half-Environment	Catastrophic Ambient contamination/permanent damage	
Operation	Catastrophic loss of operation /loss of one week	
Personal	Critical danger for the staff/risk of a death	4
Half-Environment	Critical Ambient contamination/extensive, but unsteady damage	
Operation	Deep stall of operation/loss of one day	
Personal	Moderate danger for the staff/risk of some wounded (invalidity cases)	3
Half-Environment	Moderate Ambient contamination/small damage	
Operation	Moderate loss of operation/loss of 12 hours	
Personal	Danger reduced for the staff/risk of a wounded	2
Half-Environment	Ambient contamination reduced /light damage	
Operation	Loss operation reduced /loss of 6 hours	
Personal	Worthless danger for the staff/risk of light wounds	1
Half-Environment	Worthless Ambient contamination/without impact	
Operation	Worthless loss of operation/loss of 2 hours	

CC – Class of Consequence

The main reasons for the choice of fuzzy logic in the application of problems of risk analysis, if must to the aspects: representation of uncertain or vacant variable, easy modeling of problems whose classic theories present deficiencies and easy adaptability and flexibility to assimilate new knowledge. The corrosive process will be able to install in a pipeline on-shore by means of the three forms of corrosion: Atmospheric Corrosion (AC), Corrosion of Ducts Embedded (CDE) and Internal Corrosion (IC). In this direction, the Fig. (2) shows stages executed for determination of the corrosion index (IC).

Stage 1 - Define which the main linguistic variable of entrance (Prevention and Attributes) for each type of corrosion and the linguistic variable of exit (Index of Corrosion) for ducts on-shore.

Stage 2 - Define the fuzzy sets for each one of the linguistic variables of input and output defined in Stage 1.

Stage 3 - Define the type of functions of relevancy that allow a good representation of the problem in study.

Stage 4 - Generate a base of rules taking itself in consideration the judgment and experience of specialists in the area.

Stage 5 - Correlate the methods of aggregation (Maximum/Addition) with the methods of defuzzification (Cen, Bis, Mom, Lom and Som) and to compare the results gotten with the theoretical values, aiming at to get the best configuration for evaluation of the risk.

Stage 6 - Determined to the characteristics of the System of Fuzzy Logic (SFL), to calculate the Index of Corrosion for each one of the possible types of corrosion in ducts on-Shore.

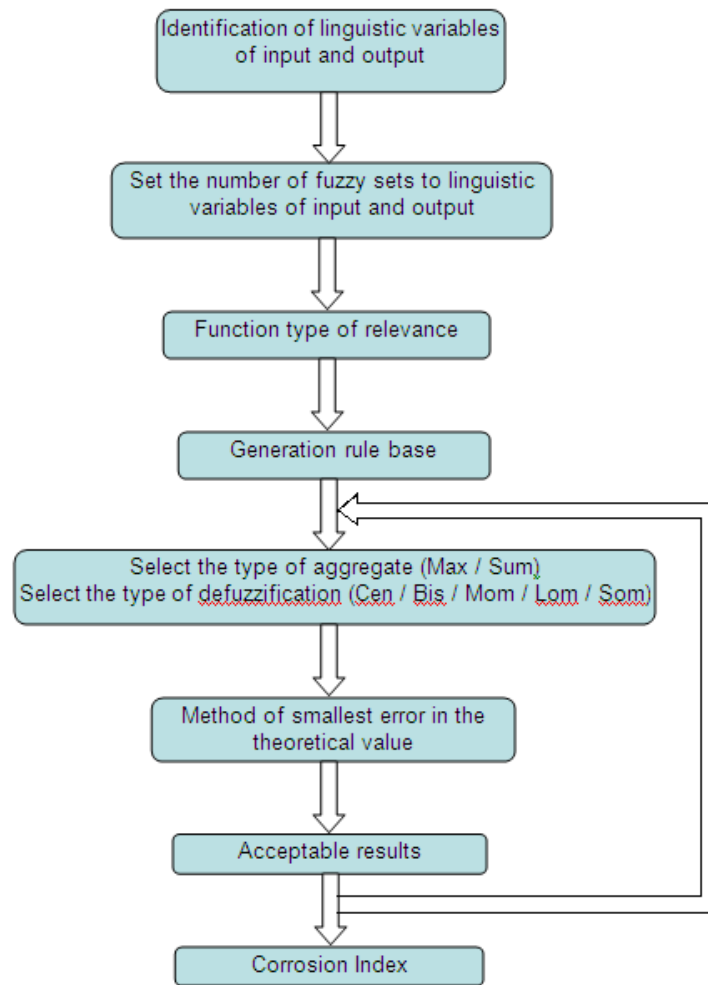

Figure 2. Flowchart with the stages executed for the development of the system of fuzzy logic.

The definition of the linguistic variable of input and output is one of the main stages in the development of the SLF. The efficiency and consistency of the results obtained by the SLF directly are related with the correct choice of these variables in relation to the problem in study. Normally these linguistic variables are defined by specialists in the area.

3. IMPLEMENTATION OF THE CONSIDERED MODEL

In this section the necessary procedures for implementation of the considered system will be boarded. Figure 3 shows the system as a whole and in the sequence, the same it will be divide block-type to facilitate the agreement. The tools of the Simulink and the Toolbox de Fuzzy Logic of Matlab 7.0. In its implementation had been used. The proposal is to implement a system capable to evaluate the risk in pipe-lines on-shore proceeding from the damage for corrosion.

Based in this context, the first step is to define the possible forms of corrosion associates to the conditions previously established. That in this in case that falls again into two conditions: Corrosion in the Embedded Duct and Corrosion in the Aerial Duct. The Fig. (3) shows to the grouping of 12 variable of entrance and the association of 11 SLF (Systems of Fuzzy Logic) for determination of the level of involved risk in the stretch in study.

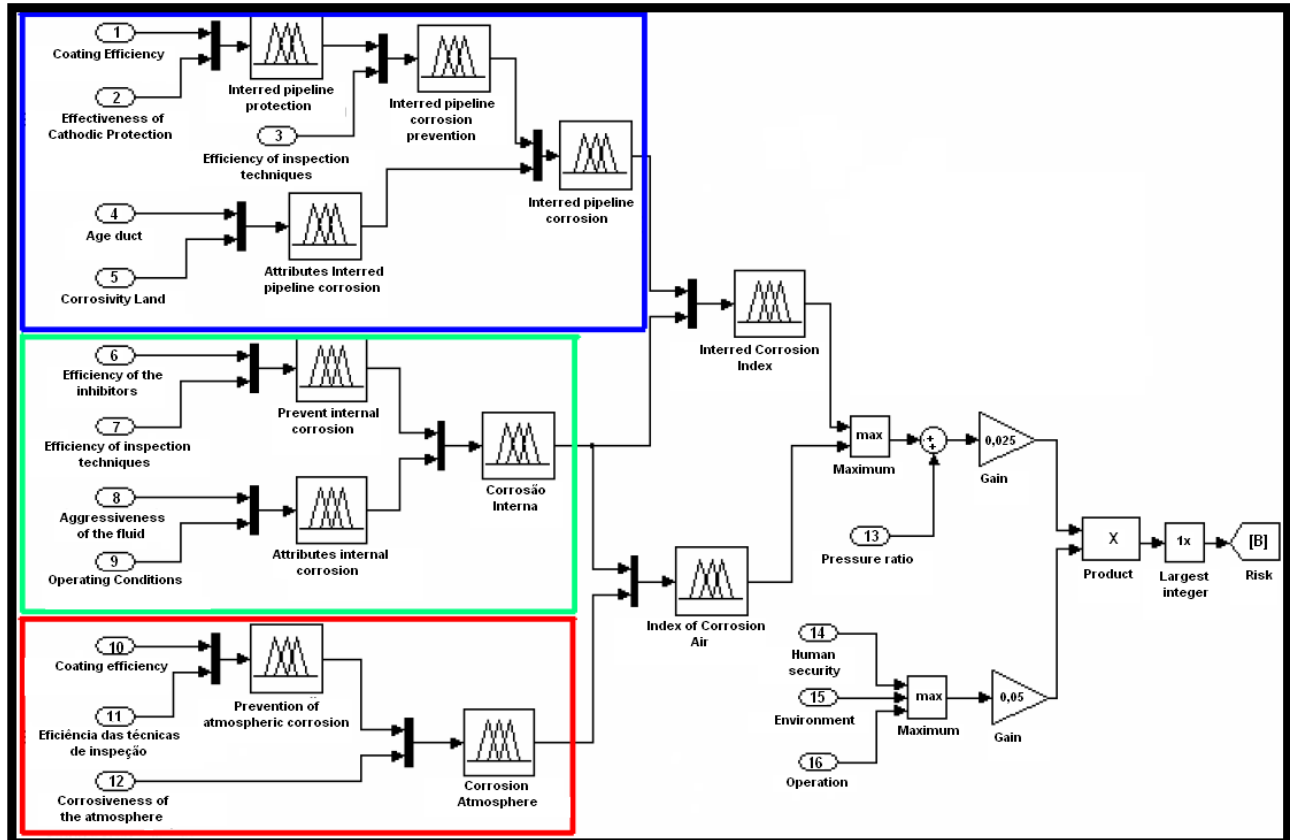

Figure 3. Model considered for evaluation of ducts on-shore.

From the result of the evaluation of Risk it was possible to optimize the regularity of inspection with Pig, leading itself in consideration the probability and the consequences associates to the imperfection for corrosion and, in such a way, to guarantee optimum use of the resources expenses with inspection and maintenance. The Tab. (3) was developed to establish the type of supervision that must be adopted and the regularity of inspection with Instrumented Pig, in function of the level of gravity found in the stretch in study, in accordance with the risk matrix (Fig. 1).

Table 3. Association of the degree of gravity with the type supervision and the regularity of inspection.

Evaluation of the Risk		Type of supervision and the regularity of Inspection with Instrumented Pig
20 – 25	Very-High (VH)	Predictive / 2 years
13 – 19	High (H)	Preventive / 3 years
09 – 12	Medium (M)	Detective / 4 years
04 – 08	Low (L)	Basic / 6 years
00 - 03	Very-Low (VL)	No Action to take / 8 years

The type of supervision is determined in accordance with the gravity level of the risk and can be classified in five periods of training, as the definitions of the Tab. (4).

Table 4. Definition of the types of supervision

Type of supervision	Description
Predictive	Esteem the period in which the probability of imperfection occurrence can be considered low or neglecter. To determine the Residual Life of the Duct.
Preventive	To foresee the possible occurrence of imperfection in the pipe-line line, through the indicative identification possible that comes to promote the beginning of the imperfection. To follow the evolution of the existing imperfections in the time. To determine the Residual Life of the Duct.
Detective	To verify the continuous absence of imperfection. To detect the latent period of training of the imperfection before the occurrence of the total imperfection in the line.
Basic	To identify abnormalities in the arrangement and the configuration of the lines. To verify of continuous form the lack of evidence of defects you observed.
No Action to take	It does not have necessity to use more sophisticated methods of inspection. And to follow the absence of imperfections.

3.1. STUDY OF CASE

In the development of the considered system the tools of the Simulink and the Toolbox de Lógica Fuzzy of Matlab 7.0. In its implementation had been used. The Tab. (5) summarizes the main characteristics of Project and Operation of the pipe-line in study. In this in case that, the considered stretch more critical if finds embedded total, then it will not have the contribution of the atmospheric corrosion (picture in red), in accordance with the Fig. (3).

Table 5. Characteristics of Project and Operation of the duct in study

CHARACTERISTICS OF THE SIMULATED DUCT	SYMBOLOG Y	DUCT 1
Carried product	Prod.	Ethylene
Type of Revestiment	Rev.	Mineral coal-epóxi tar
Material of pipe-line	API 5L	DEGREE 60
Age of the pipe-line (years)	T _o	5
Tax of corrosion (mm/years)	R _d	0,20
Depth of the remaining defect (mm)	d _o	1,00
Espessura do Duto (mm)	T	12,7(1/2")
Extension (km)	L	50
Diameter (pol)	D	16
Limit of Draining (MPa)	SMYS	317,40
Maximum Pressure of Operation (PSI)	MAOP	650
Pressure of Project (PSI)	P _p	2700
Pressure of Operation (PSI)	P _o	640
Average outflow (m ³ /h)	Q	670
Coefficient of Security	CS	1

Initially the entrances of variable (prevention and attributes) are represented through qualitative values and into the sequence they are transformed into quantitative values in accordance with the Tab. (6).

Table 6. Characteristics of the prevention of variable and attributes

TYPE OF CORROSION	CLASS	VARIABLE LINGUISTIC	QUALITATIVE / QUANTITATIVE
Index of Corrosion Duct Embedded (ICDE)	Prevention	Efficiency of Revestment (ER)	Raised / 75%
		Efficiency of Protection Cathodic (EPC)	Raised / 75%
		Efficiency of the Techniques of Inspection (ETI)	Raised / 75%
	Attributes	Age of Duct (AD)	Very Low / 0%
		Corrosivity of Ground (CG)	Average / 50%
Index of Corrosion Intern (ICI)	Prevention	Efficiency of Inhibitors (EI)	Average / 50%
		Efficiency of the Techniques of Inspection (ETI)	Raised / 75%
	Attributes	Aggressive of Fluid (AF)	Average / 50%
		Operational Conditions (OC)	Low / 25%
Index of Corrosion Atmospheric (ICA)	Prevention	Efficiency of Revestment (ER)	-
		Efficiency of the Techniques of Inspection (ETI)	-
	Attributes	Corrosivity of Atmospheric (CA)	-

The imperfection probability is given by the it adds enters the Maximum Index of Corrosion (MIC) and the Relation enters the Pressures of Operation and Project (β), in accordance with the Fig. (3). How much to the consequences of a possible emptying, the stretch in study is located in a region little inhabited (worthless danger for the staff/risk of light wounds), of average ambient sensitivity (moderate ambient contamination/small damage) and that the occurrence of a possible emptying implies in a moderate loss of operation (equivalent the 12 hours of interruption), as Tab. (2).

Considering to the data of Project/Operation, the involved characteristics of the variable prevention attributes and consequences, the stretch in study meet with level of equal risk the 4 (four), that it is considered Low according to Tab.(3). In this in case that, a basic accompaniment sends regards, whose objective is to follow of continuous form the lack of evidence of defects observed. And in function of low the critical of the stretch, sends regards a regularity of inspection of 6 (six) years with Instrumented Fig.

4. CONCLUSIONS

The gotten results had served to evaluate and to validate the model considered. From the same ones it was possible verified consistency and coherence of the same ones in relation what it would be waited in the practice.

In the sequence the main conclusions will be presented:

1. The application of the theory of the Fuzzy Logic demonstrated to be sufficiently pertinent in the evaluation of the risk in pipe-lines systems. This conclusion is based on three aspects: amount of involved subjective variable, easy modeling of problems whose classic theories present deficiencies and flexibility and adaptability in assimilating new knowledge.
2. The perspective of the research in the area of risk analysis meets in the management of the information. This affirmation is possible, due to amount of information required for the risk analysis. Thus, the capacity with that the

operators of ducts have in getting these information of form more coherent with the reality, certainly will reflect in an analysis more trustworthy insurance and on the part of the risk analyst.

3. In accordance with the gotten results the risk of occurrence of emptying in a duct proceeding from the corrosive process is influenced by the operational conditions, the actions of prevention/attributes and by the involved consequences in the emptying.

4. Although the considered System to associate the risk in the transport of oil and its derivatives only to the mechanism of the corrosion, the gotten results had been sufficiently representative. This demonstrates how much the corrosion is significant in the treatment of the integrity in pipe-lines.

5. REFERENCES

- Cunha, S. B., "Otimização de Programas de Inspeção de Dutos por Pigs de Corrosão", Conferência sobre Tecnologia de Equipamentos – 5^a COTEQ, Petrobras, 9 p., São Paulo, Brasil, 2001.
- Donato, G.V.P., 2001, "Commentaries on the Effectiveness of the Inspection, according to Concepts of API-581 (RBI) - Risk Based Inspection", Conference on Equipment Technology - 5^a COTEQ, Petrobras/Cenpes, 9 p., São Paulo, Brazil.
- Eckstein, C.B., Tinoco, E.B., Saints, I.S., Etter, J. the N., 2001, "Established Inspection at risk according to API-581 applied in tubings of refineries" Conference on Equipment Technology - 5^a COTEQ, Petrobras/Cenpes, 7 p., São Paulo, Brazil.
- Mishina, K.D.V., Silva, J.F., Silva, J.B., 2001, "Survey of the Techniques of Inspection in Ducts and the criteria used in the Otimização de Programas de Inspeção", Magazine Technique of Energy Oil and Gas, Number 2, Year 1, pp. 65-69.
- Mishina, K.D.V., Silva, J.F., Silva, J.B., 2002, "Boarding on established Inspection at risk according to API-581", National Congress of Engineering Mechanics - CONEM 2002.
- Pimenta, G.S., 2001, "General Boarding", ABRACO - Brazilian Association of Corrosion.
- Silva, J.M., 2001, "Monitoramento of the Internal Corrosion of Ducts and Natural Gas Installations", Conference on Equipment Technology - 5^a COTEQ.
- Silva, J. M., 2001, "Supervise of the internal corrosion of ducts and natural gas installations", Conference on Equipment Technology - 5^a COTEQ, Petrobras/Cenpes, 9 p., São Paulo, Brazil.

6. RESPONSIBILITY NOTICE

The authors are the only responsible for the printed material included in this paper.