

## DESIGN AND DEVELOPMENT OF A WIRELESS PITOT TUBE FOR UTILIZATION IN FLIGHT TEST

**Igor Machado Malaquias, imalaquias@yahoo.com.br**

**Antonio Rafael da Silva Filho, arafael@ufmg.br**

**Paulo Henriques Iscold Andrade de Oliveira, iscold@ufmg.br**

Universidade Federal de Minas Gerais – Departamento de Engenharia Mecânica – Av Antonio Carlos, 6627 – Pampulha – Belo Horizonte – Minas Gerais – Brasil, CEP 31.270-901 – (PPGMEC) Programa de Pós Graduação em Engenharia Mecânica

**Gonçalo Daniel Thums, goncalodt@yahoo.com.br**

Universidade Federal de Minas Gerais – Departamento de Engenharia Elétrica – Av Antonio Carlos, 6627 – Pampulha – Belo Horizonte – Minas Gerais – Brasil CEP 31.270-901

**Abstract.** *This paper presents the design and manufacture of a wireless Pitot tube for use in flight tests, it is also presented the mechanical design, electronic, calibration and validation trial of such equipment. The Pitot tube in question was designed to operate together with the data acquisition system developed at Centro de Estudos Aeronáuticos at Universidade Federal de Minas Gerais (CEA-FDAS – “Flight Data Acquisition System”). CEA-FDAS is a low cost data acquisition system for use in flight tests, which can be coupled to several sensors / devices. One of these devices, as in conventional flight test system consists of a Pitot tube with four sensors, which in most cases must be installed on the wingtip of the aircraft, with the acquisition of static and dynamic pressure, and even a set of two flags to determine the angles of attack and sideslip. The fact that the Pitot tube in question has no wires to connect with the data acquisition system is its best advantage when compared to its peers, what makes the installation process very simple and fast in addition it is compatible with any type of aircraft by simply providing the attachment means to this structure. Therefore, there is no need for installing cables and hoses on the outside or inside of the wings of the aircraft, as it should be done in a conventional Pitot tube, what can often affect the aerodynamics of aircraft. The system is divided into three parts, the Pitot tube itself, where the sensors are installed, the sampling circuit (microcontroller and A / D converter) and the transmitter. Inside the aircraft is the second part of the system which comprehends the receiver, microcontroller and D / A converter, this one is responsible for providing four independent analog outputs, and each one of them has a value of DC voltage proportional to the quantity measured. These outputs are then connected to the CEA-FDAS data acquisition system inputs. Thus, it is possible to know the informations about the static and dynamic pressures, and angles of attack and sideslip.*

**Keywords:** *Pitot tube, Flight test, Data Acquisition*

### 1. INTRODUCTION

This paper presents the design, development and manufacture of a wireless Pitot tube to be used in flight tests. This tube will be used to measure the speed, static pressure (to determine the altitude) and also the angles of attack and sideslip of the aircraft. The Pitot tube will work together with a data acquisition system called CEA-FDAS (Flight Data Acquisition System) that is an acquisition system developed at CEA – Centro de Estudos Aeronáuticos (Center of Aeronautical Studies), from Universidade Federal de Minas Gerais (Oliveira, 2008).

The Pitot tube is an instrument developed by the French physicist Henri Pitot, in the eighteenth century to measure the speed of the fluid flow (Anderson, 1991). Its working principle is based on pressure sensors (which may be a simple column manometer, or a digital sensor) that measure static and total pressure of a fluid in motion. Through the differences between these two pressures it is possible to determine the dynamic pressure of flow and then calculate its speed according to equation (1).

$$V = \sqrt{\frac{2 \cdot \Delta P}{\rho}} \quad (1)$$

Where  $\rho$  represents the density of the fluid, and  $\Delta P$  the difference between the static and total pressures (dynamic pressure). For a density in kg/m<sup>3</sup> and a pressure in Pa, respectively, we get to the speed in m/s.

The Pitot tube has nowadays a wide application specially in the aeronautics field, being the main way to measure the airspeed of an aircraft flying.

A major problem of the utilization of the Pitot tube in an aircraft is its installation. In general, the equipment must be installed at the wingtip of the aircraft, and the acquisition system and data processing is in its interior. Therefore, it is required to establish anyhow the communication between them.

In a conventional Pitot tube, this communication is made through tubes (pressure lines) or wires, with the electrical signals from the detectors. However, there is always a difficulty in the installation of the equipment, because not all the time one has access to the interior of the wing to install the cables and, very often the installation of the tubes and cables on the outside of the wing, when not predicted in design, can be dangerous to the flight and even reduces the operational safety of the aircraft.

For this reason, a Pitot tube that can communicate to the data processing central through a wireless network, is of extreme importance, largely by facilitating the installation of the tube at the wingtip or at any other part of the aircraft. Furthermore, it makes the procedure safer. Because of those facts, it was chosen to manufacture a wireless Pitot tube that attended to the operation needs of the flight test at CEA.

In the next topics, it will be presented the mechanical and electronic design of the equipment, the calibration procedure, and an example of its application in a flight test.

## 2. THE PITOT TUBE PROJECT

The fabrication of the pressure sensors probe of a Pitot tube must follow some rules so that the measurements can be trusted. The Pitot tube is composed of its probes; one of them is for the static pressure taking at its the sides and another for taking the total flow pressure (or stagnation pressure) located at the end of the tube. The shape of the air takings (in relation to the input) and the position must be studied. The Pitot tube proposed has also two flags located on its sides at 90 degrees one from another, to be responsible for the determination of the incident flow degree on the Pitot tube.

Next, there is a brief description about the design of each part of the Pitot tube.

### 2.1. Total pressure taking

The geometric shape of the frontal air taking of the Pitot tube (total pressure taking), influences directly the tube's errors sensitivity related to the its non-alignment with the flow. Since the designed Pitot must work in an airplane, where there is incidence of a flow not-aligned with the tube, it is necessary to examine this effect.

Benedict (1984) presents a study on the tip shape of the Pitot tube and its influence on error due to this alignment, Figure 1. Therefore, it was chosen for the Pitot concerned the shape indicated by a filled triangle, for a balance between quality and ease construction.

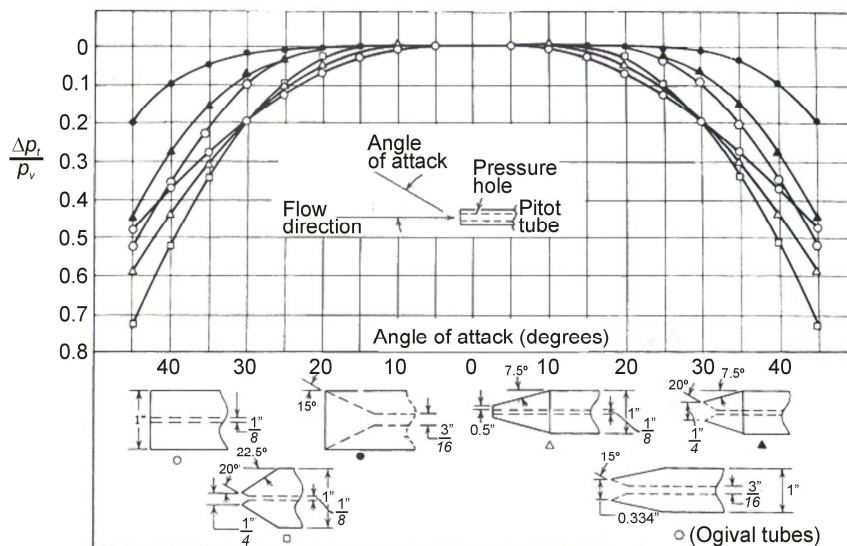

Figure 1 – Influence of the shape in the total pressure taking

### 2.2. Static Pressure taking

When taking the static pressure there is also a concern about the correct installation of the equipment to minimize the errors in the system. Benedict (1984) recommends that the takings be distributed along a line across the tube face so that the average pressure in the center becomes equal to the flow in case of misalignment, and the takings positions along the tube longitudinally should be a commitment to the reduction “nose effect” and “stem effect”, Figure 2. The relation chosen was  $x_s = x_h = 4D$ , because it was required that there was a commitment between the reduction of the

measurement errors, sufficient tube diameter for the installation of the sensors, and the compactness of the system as a whole.

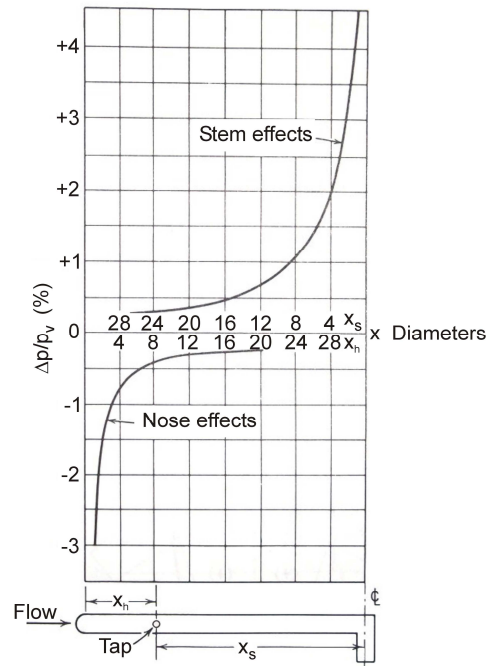

Figure 2 – Influence of the total pressure taking

### 2.3. Flow direction flag

The flags used to measure the direction of the incident flow of the tube were installed on its sides, after taking the static pressure, in a section where it was needed to increase the diameter of the tube for the position sensors installation of each flag. The two flags were installed each one bi-supported in two mini-bearings so they could spin freely following the direction of the flow.

### 2.4. Final aspect of the instrument

Figure 3 shows a tridimensional model with the final aspect of the Pitot tube. A great part of the constant section at the end of the mechanism can be observed. This part is required to comprehend all the electronic apparatus and data transmission system that will be described later.

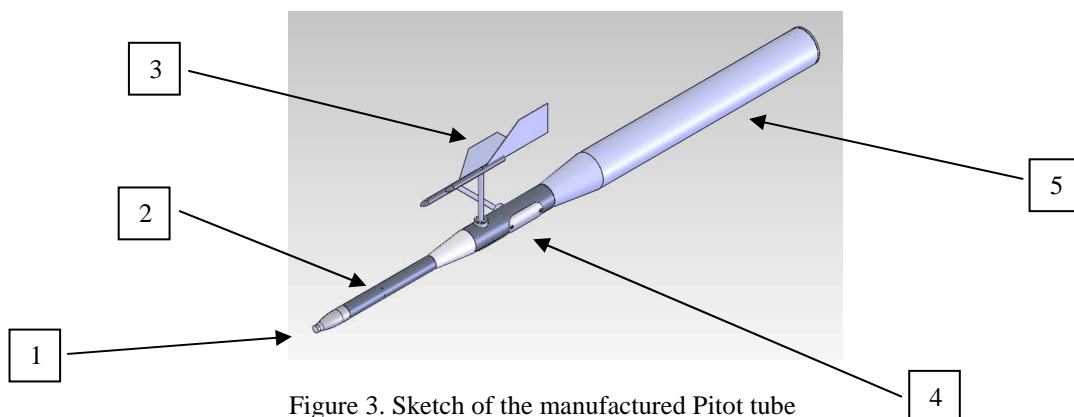

Figure 3. Sketch of the manufactured Pitot tube

The indications represent:

1. Total pressure taking.
2. Static pressure taking.
3. Flag for determining the flow direction.
4. Covers to give access to the bearing and sensors of the flags.
5. Section for conditioning the electronic apparatus.

Figure 4 shows the Pitot tube completely finished on the support used for calibration in the wind tunnel.



Figure 4. Final aspect of the Pitot tube

### 3. ELECTRONIC SYSTEM

The wireless electronic part of the Pitot's tube is divided into two distinct parts, the sampling and transmission circuit, located within the Pitot tube, and the reception unit.

Inside the Pitot tube there are the static and dynamic pressure sensors, and the Hall Effect sensors which are responsible for detecting the attack and sideslip angles of the flags of the aircraft. Moreover, in this part of the system are installed signal sampling circuits and the transceiver, acting as a transmitter.

At the reception unit, installed inside the aircraft, there is another transceiver, in this case, acting as receptor, and the D/A converter circuits.

Therefore, in the Pitot tube, the signals coming from the sensors are sampled and sent through a serial communication, in text format, to a transmitter module that transmits it through a radio frequency link, i. e., wirelessly, to the reception unit. In this unit, the serial format received sign is converted to the standard SPI<sup>1</sup> and sent to the D/A converter. Once reconstructed, the analogical signals of each sensor are sent to the data acquisition system, the CEA-FDAS, using four independent channels.

Figure 5 shows the general diagram, in blocks, of the whole system.

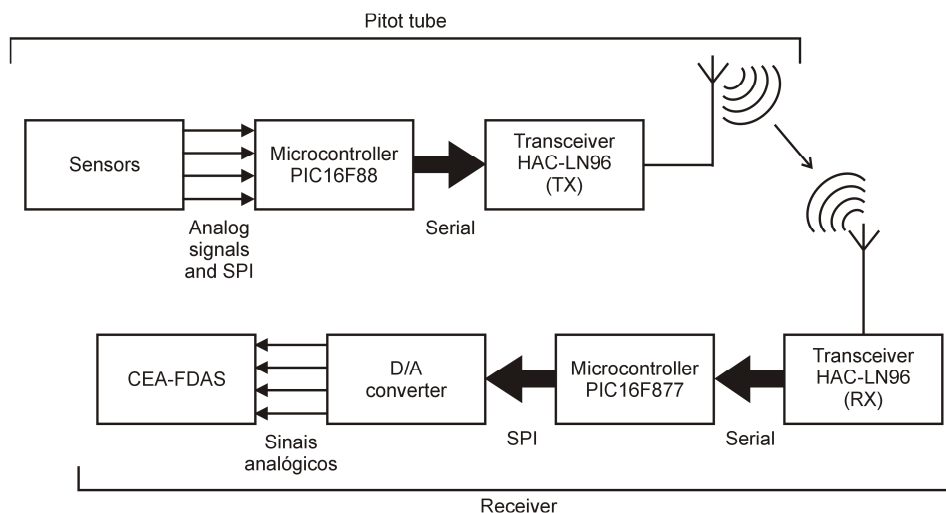

Figure 5. General diagram of the system

In the next section, more details about the transmitter and the reception unit are presented.

#### 3.1. The transmitter

In the Pitot tube are installed two Hall Effect sensors, model A3515 produced by Allegro Microsystems (Allegro, 2011) that converts the position of the attack and sideslip angles of the flags into DC signals and which value is

<sup>1</sup> SPI - Serial Peripheral Interface

proportional to the positions of them. To measure the dynamic pressure, it is used the pressure sensor MPXV5004 of Freescale Semiconductor, which also has an analogical output. Hence, the signals from the Hall Effect sensors and dynamic pressure sensors are connected to three A/D converters in the sampling microcontroller.

To measure the static pressure, it is used a pressure sensor SCP1000 of VTI Technologies. This sensor, in opposition to the rest, has a standard SPI digital output, and thus being connected to the microcontroller through its SPI port.

The choice of the microcontroller, in this case, the PIC16F88 from Microchip, was made according to the available peripherals of it. In this situation, they were the analogical signals inputs (A/D converters), standard SPI port and serial communication port standard RS232 (USART).

The microcontroller, in addition to performing the analogical signals sampling, also has the function to convert the sampled informations into text format and send them to the radio transmitter, this one will send the data to the receptor inside the aircraft. The diagram in blocks of the transmitter is presented in figure 6. Figure 7 shows the final aspect of the data transmitter circuit that is installed on the larger diameter tube at the back of the tube.

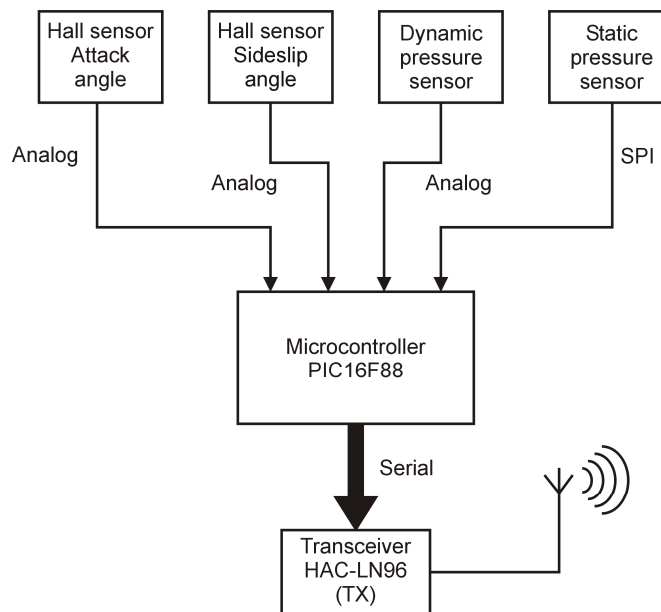

Figure 6 – Transmitter diagram

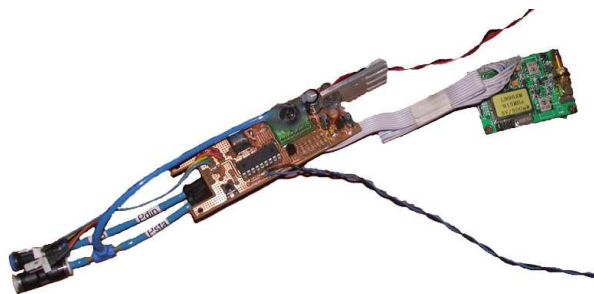

Figure 7. Pitot's internal transmitter system (without the battery)

A rechargeable battery NiCd with capacity of 600mAh and nominal voltage 9,6 V is used to power the Pitot tube. With this battery, it was reached a range of approximately one hour and thirty minutes for the system, according to the battery discharge curve in Figure 8. This curve was obtained with the load circuit of the Pitot tube, i. e., a real loading situation.

### 3.2. The receptor

The receiver unit is composed by a transmitter, acting as a receiver, that receives the data through the wireless interface and let the data available at another interface output in the standard RS232. The available data, in text format,

are sent to the microcontroller, PIC16F877 also of Microchip, where they are converted to standard SPI and sent to the D/A converter, model DAC7554 produced by Texas Instruments.

The choice of D/A converter was based on its resolution (number of bits in this case 12 bits), and the number of output channels.

Therefore, the receiver unit provides four independent analog outputs, and each one of them corresponds to a quantity being measured. These outputs are then connected to the data acquisition system inputs, CEA-FDAS.

Figure 9 shows the diagram in blocks of the receiver unit, whereas in Figure 10 it is presented a picture with the conditioning aspect of this receiver system.

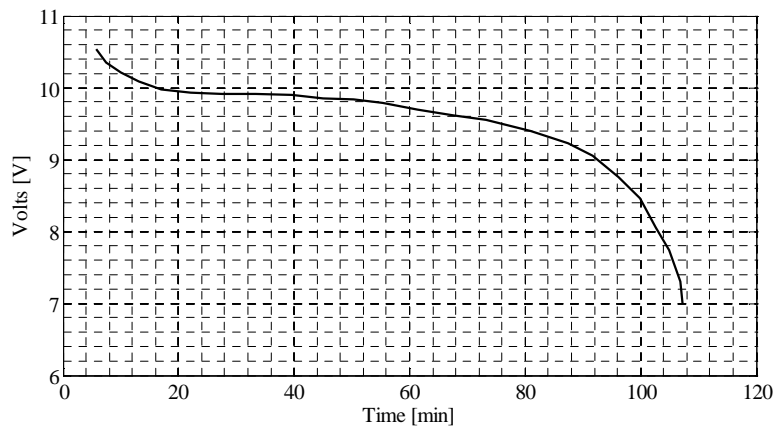

Figure 8. Discharge curve – Battery NiCd 9.6V 600mAh T = 21°C

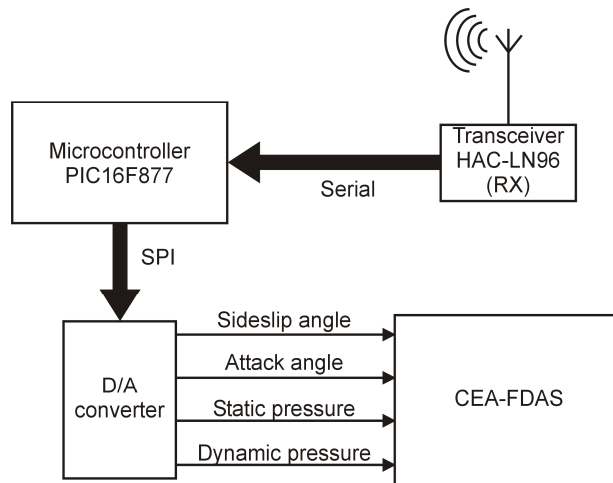

Figure 9. Diagram in blocks of the receiver unit



Figure 10. Aspect of the receiver

Regarding the power of the receiver unit, it is provided by the CEA-FDAS itself. CEA-FDAS can have its own battery or it can be powered by the aircraft's power circuits.

#### 4. CALIBRATION OF THE SYSTEM

The system's calibration was divided into two parts, a wind tunnel, where the flags of the flow direction measurements were calibrated, and another at the outside of the wind tunnel, where the static and dynamic pressure sensors were calibrated independently.

This separation is due to the fact that the available wind tunnel is small, reaching speeds of up to 25 m/s, and not being possible a great reduction in the static pressure and obtain high speeds. This fact made impossible the calibration of the pressure sensors inside the wind tunnel, because it could not achieve the speed ranges and static pressure required inside the Pitot tube.

The tunnel in use is a small teaching tunnel at Universidade Federal de Minas Gerais (Filho, 2005). Figure 11 presents a Pitot tube mounted inside the tunnel for calibration, where it also can be observed a second Pitot tube, responsible for measuring the tunnel flow.

In sequence, it is made a brief description of each stage of the calibration. In the calibration procedure it is supposed to obtain a curve that relates the output signal of the acquisition system with the physical quantity measured by the instrument.

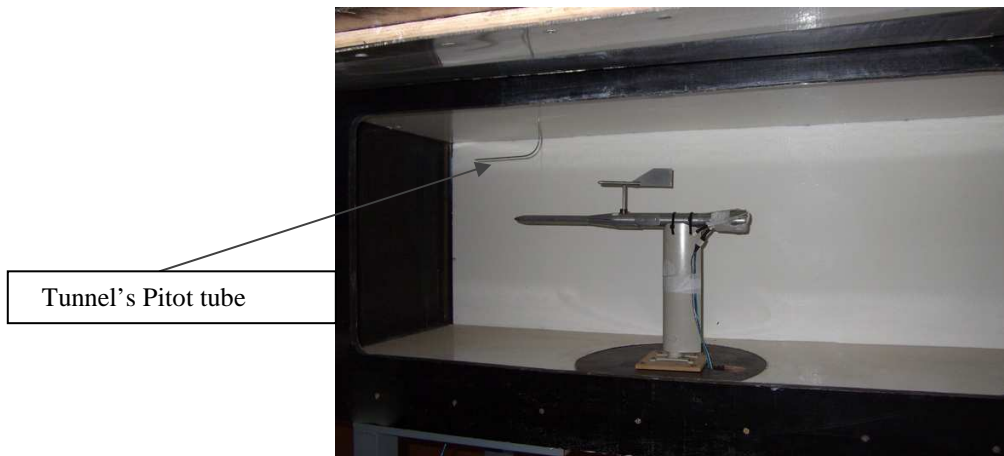

Figure 11. Pitot tube mounted inside the wind tunnel

##### 4.1. Calibration of the static and total pressure probes.

As described previously, due to low capacity of the wind tunnel, the errors in the static and total pressure takings of the Pitot tube were only verified for low speeds (at the possible procedure in the tunnel). Because of that, the data of the Pitot test were compared to the data of the Pitot of the tunnel. The pressure measurement was performed using an U-tube manometer, and the comparison between the two Pitot indicated that the errors in the operating range of the tunnel were less than 1%.

##### 4.2. Calibration of the flags

The wind tunnel was used for the calibration of the flags, where there is a spinning and graduated table. When the tunnel is at work, it is possible to spin the Pitot tube inside of it so the flags remain aligned with the flow.

Since the table is graduated, it is possible to know the position of the Pitot tube in relation to the flow and, through the output signal of the acquisition system, trace the curve relating the output signal, and the angle of each flag in relation to the flow.

Due to the limitations of physical space in the tunnel, the calibration limits for each of the flags were from -30 to +30 degrees, values that are sufficient for the operating range of angle of attack and sideslip of an aircraft.

Figure 12 presents an example of the calibration curve of one of the flags, the polynomial fit chosen is indicated in the chart.

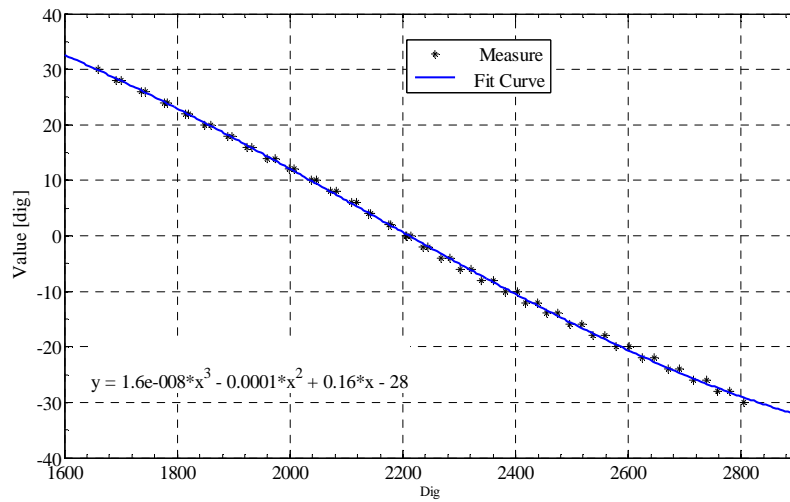

Figure 12. Calibration curve of one flag

### 4.3. Calibration of the pressure sensors

For the calibration of the pressure sensors it was used U-tube manometer, and the application of pressure in the sensors was performed using a surgical syringe. This way it could be applied a certain amount of pressure to the sensors and through the U-tube, identify the value of applied pressure, then, knowing the response signal of the acquisition system, determine the calibration of the sensors.

Figure 13 shows the apparatus used for the calibration of pressure sensors, and in Figure 14, there is the example of the calibration curve of one of the sensors, here, the static pressure sensor. In the graph there are also the coefficients of the polynomial fit chosen for the curve.



Figure 13. Scheme for the calibration of the pressure sensors

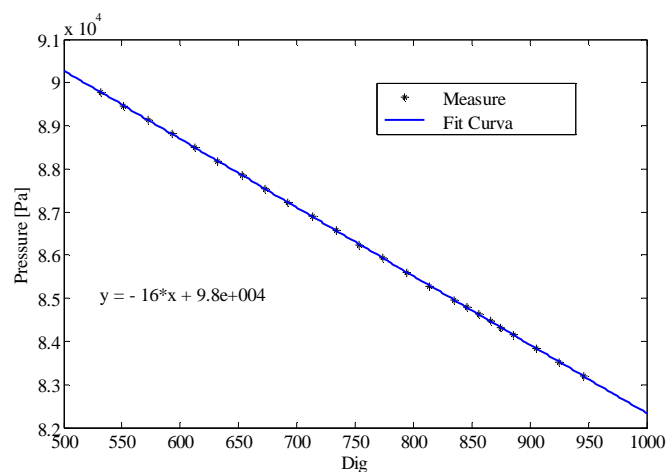

Figure 14. Calibration curve of the static pressure sensor



## 5. APPLICATION

The wireless Pitot tube at CEA has been applied successfully in several flight test operations at Centro de Estudos Aeronáuticos (Center for Aeronautical Studies) at UFMG. Some highlights of CEA are: i) testing of equipment and flight test classes on the UFMG's Curumim aircraft. ii) testing of aircraft CEA-309, produced in acrobatic UFMG, ii) testing the P-1 glider, produced in ITA, iv) testing the aircraft ACS-100 Sora, v) testing the aircraft K-51 Peregrino.

Figure 15 presents a set of data obtained from the Pitot flight test aircraft ACS-100 Sora. In this graph, it can be seen the altitude data (from the static pressure probe), speed and angles of attack and sideslip. All of them obtained from the wireless Pitot tube developed. The presented data refer only to one lane shift of the aircraft, and yet are not treated. They are presented here only as an example.

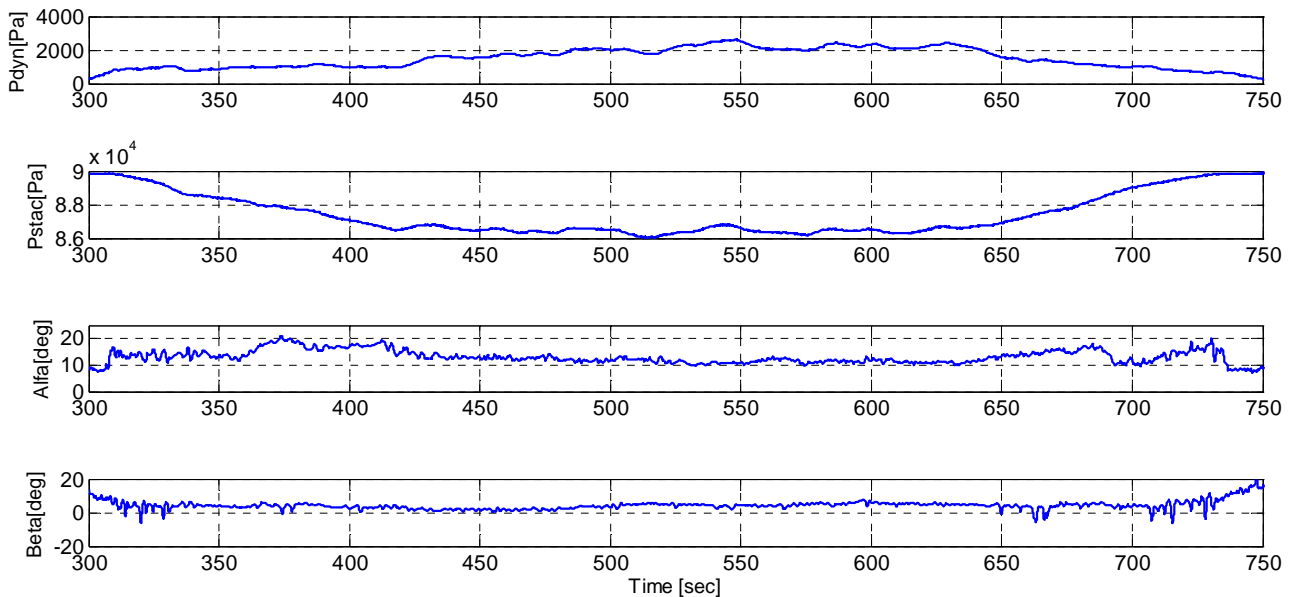

Figure 15. Example of data of ACS-100 Sora

## 6. CONCLUSION

In this paper it was described the design and development of a Pitot tube for use in wireless flight tests. The study highlights its great advantage, especially having in mind the operation without wires and hoses, facilitating its installation on the aircraft.

It was presented the development of the probes of the total and static taking, the measuring flags of the incident direction of the flow, and the entire processing system, and data sending to the data acquisition system.

The system has been of great use in procedures for flight tests of the CEA's aircrafts, and it is widely applied successfully in these operations and produces consistent and reliable results.

## 7. ACKNOWLEDGEMENTS

The authors would like to acknowledge FAPEMIG (Fundação de Amparo à Pesquisa do Estado de Minas Gerais) for the financial support during the Project.

The authors would also like to acknowledge Larissa Cristina de Camargo for helping to elaborate this paper.

## 8. REFERENCES

- Allegro. 2011 "<http://www.allegromicro.com/>" (Retrieved January 2011)
- Anderson, J.D. Jr. 1991. "*Fundamental of Aerodynamics*" McGraw-Hill Series in Aeronautical and Aerospace Engineering. Second Edition.
- Benedict P. R. 1984. "*Fundamentals of Temperature, Pressure and Flow Measurements*" Third Edition, John Wiley & Sons.
- Filho, A.R.S., Oliveira, P. H. I. A. 2005 "Projeto e Construção de um Túnel de Vento Subsônico, Didático de Pequeno Porte". XII Congresso Nacional de Estudantes de Engenharia Mecânica, Ilha Solteira – São Paulo.

Oliveira, P. H. I. A. 2008 "*Low-cost Flight Test System for Light Aircrafts*". Aircraft Engineering and Aerospace Technology: An International Journal. Emerald Group Publishing Limited.

## **7. RESPONSIBILITY NOTICE**

The following text, properly adapted to the number of authors, must be included in the last section of the paper:  
The author(s) is (are) the only responsible for the printed material included in this paper.