

AN AUTOMATIC SYSTEM FOR ELECTRODYNAMIC SHAKER CONTROL BY ACCELERATION POWER SPECTRAL DENSITY

Herbert Martins Gomes, e-mail: herbert@mecanica.ufrgs.br

Franklin de Souza Ferreira, e-mail: franksfbr@yahoo.com.br

Carlos Alberto Kern Thomas, e-mail: thomas@mecanica.ufrgs.br

UFRGS, Universidade Federal do Rio Grande do Sul, Programa de Pós Graduação em Engenharia Mecânica,
R. Sarmiento Leite, 425, 90050-170, Porto Alegre, RS, Fone: +55 (51) 3316-3255

Douglas dos Santos Gaspareto, e-mail: douglas.gasp@gmail.com

UERGS, Universidade Estadual do Rio Grande do Sul, Rua Inconfidentes, 395, 93340-140, Novo Hamburgo,
Brasil, tel.: (51) 3595-8091

***Abstract.** This work presents the main results of an electrodynamic shaker's closed loop active control to generate Accelerations Power Spectral Densities (PSD) according to prescribed Standards. The main idea starts generating pseudo-signals obeying the power spectral density and then acquiring acceleration data from electrodynamic shaker's behaviour. It was noticed that for piecewise narrow bands frequencies the electrodynamic shaker acceleration responds near linearly with frequency and with voltage input signals. It was developed a code in AgilentVee 7.5 software to acquire, send and process signals for the control in real time. The hardware used a sound card from a PC. The control could be accomplished sending and acquiring at the same time with a range of input/output of $\pm 1.5V$, at 48 kHz, 16bits of resolution and assist of an external sound amplifier.*

***Keywords:** Active Control, Electrodynamic Shaker, Power Spectral Density, Sound Card.*

1. INTRODUCTION

There is a general trend on increasing the reliability of several devices (mainly those with critical component) which are tested and used at adverse conditions. This is accomplished by vibration tests because this is the main phenomenon responsible for the durability and serviceability of such devices. The main purpose of this work is the development of a system to control an electrodynamic shaker with relative accuracy through a closed loop. The main variable of control is the shaker's table acceleration. The function to be minimized is the difference between the Acceleration Power Spectral Density of the shaker and a Standard Acceleration Power Spectral Density indicated.

The developed system makes possible perform tests, such as: mechanical fatigue strength, evaluation of resonant frequencies (by sine sweeps or random vibrations), replication of acquired acceleration's field signals, impact strength, shock, fall and general modal analysis.

1.1. Electrodynamical Shaker

Shaker is any device that applies vibration on test pieces (alternate acceleration with known frequencies) in a controlled way. The main work operation principle may be based on combustion engines, hydraulic engines, pneumatic or electrodynamic ones (this work).

The electrodynamic shaker works based on the electromagnetic forces generated by two interacting magnetic fields generated by coils. One of them has its own magnetic field proportional to the applied voltage the other has a static magnetic field. There is a fixed armature for one coil and another acting armature that supports the test specimen where the acceleration is measured for the active control.

Figure 1 shows two typical sketches and setups of electrodynamic shakers. Figure 1 b) resembles the shaker used in this work.

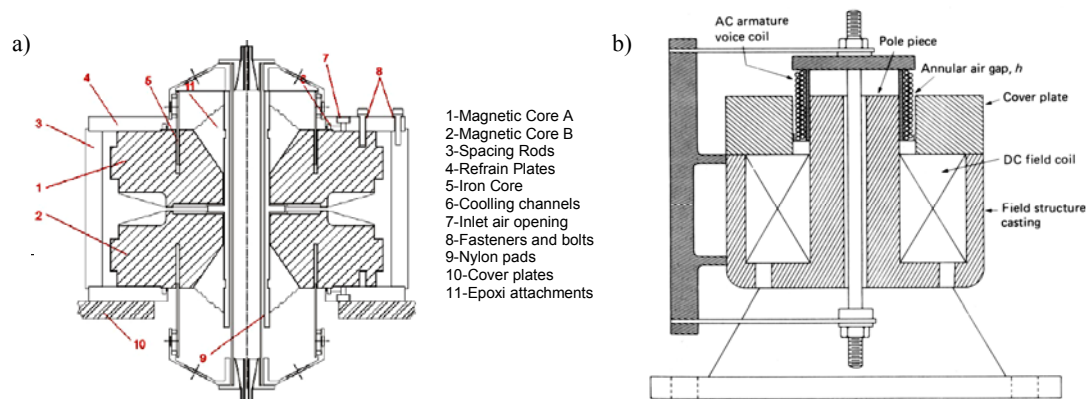

Figure 1. Sketch and setups of typical electrodynamic shakers

1.2. Brief bibliographical review

In recent works M. Fujita *et al.* (2005) and Y. Uchiyama *et al.* (2006), achieve the electrodynamic shaker robust control by means of the acceleration and displacement control of the shaker's table. The work presents the acceleration and displacements control of an electrodynamic shaker that couldn't be controlled by standard control methods. Two control variables are used in order to control a broad frequency band. The acceleration control is used on frequencies bands where the response signals are larger than the noise. The displacement control is used for lower frequencies bands. Both methods are coupled in series. The control's software is projected using the μ Synthesis Method with two degrees of freedom in order to improve the system transient response. Finally the authors tested the developed control on an electrodynamic shaker. In the end, some comparisons are drawn between the proposed control system and a standard single loop.

Cavaliere and Cavalca (2004) presented an implementation of one wave vibration test. This implementation was based on the LabView software acting as a signal generator. The main purpose was to generate vibrations with several wave shapes.

Salehzadeh-Nobari, *et al.* (1997) presented an adaptive control on the frequency domain. The authors stated that the correct choice of the control technique is dependent on the system modelling assumptions and using available high level software tools the adaptive inverse control technique shows to be suitable mainly on situations where non-linear behaviours are presented as in vibration tests. The focus of the paper is the design of controllers by means of the "Teaching Company Scheme" and the impact of this development on the "Ling Dynamic Systems" (LDS), a manufacture company of industrial vibration test machines. The work includes some short description of the vibration systems and the uses in industry followed by explanations concerned with the choice of the used algorithm and the main steps for its implementation on specific hardware.

Flora and Gründling (2006) presented an interesting work where it is shown the development of digital acceleration controllers for sinusoidal vibration tests using a switching-mode AC power source-ACPS with an electrodynamic shaker. The used electrodynamic shaker was of the same manufacturer, model and load capacity than that used in this work. The proposed scheme is based on two control loop interaction: one of them for the acceleration regulation and the other one for the ACPS voltage output. It is used an algorithm for robust control (Robust Model Reference Adaptive Algorithm - RMRAC) in order to reduce the effects caused by the variations on the system and to reduce the harmonic and resonant vibrations on the test piece. The acceleration controller is improved with a feedforward and a Robust Controller. The experimental results have shown that the proposed system is able to attain a good performance in standard frequency bands from 20 Hz to 1 kHz.

Moutinho, *et al.* (2004) describes the implementation of an active control system applied to a vibration table used for seismic vibration tests on reduced scale test specimens. In agreement with the authors the use of such a control system is intended to impose an *a priori* movement to the shaker's table, which is strongly depended to the interaction between the table and the test specimen as well as random phenomena associated to experimental tests. That paper describes the working principle and implementation of the proposed active control developed in LabView software and compares the efficiency with those evaluated using two different control strategies: the first one using a Proportional Differential and Integral controller (PID) and a second one using a predictive controller. The controller was implemented in the following equipment: a vibration platform, a unidirectional electrodynamic exciter APS, model 400 by ELECTRO-SEIS and an adaptive aluminium table for model support. The total mobilized mass limit was 12.32kg. The PID controller was less efficient than the predictive controller in the evaluation the desired measured response (particularly in sudden movement variations), as much as in maximum amplitude load control. However, it does not require a numerical model to generate the control action necessary in the predictive controller.

2. TESTS AND VIBRATION TEST EQUIPMENTS

A modern vibration system is composed by three main devices: a vibration exciter, an amplifier and a control system. The vibration exciter transforms the electrical energy on vibration movements applied to the test specimen, often providing ways to study the damage evolution while in normal operation. The amplifier transfers the power from the line source and transforms it on electrical signals of desired frequency and amplitude. The controller monitors the vibration test, the output exciter acceleration and supplies the adequate input signal for the amplifier.

The vibration amplifier requires some features that are not necessary on common applications. In addition, for an adequate load ratio, moving the vibration exciter with the right force requires the amplifier to dissipate and absorb reactive loads from alternating levels of impedance. The amplifier distortion is a severe subject since the distortion itself can easily harm the test specimen. So the amplifier distortion should be kept below 3% or less than 2% on critical regions where harmonic vibrations could excite shaker's fundamental frequency.

The main tasks of a modern shaker arise from the several types of controller systems available. These tasks could be grouped on two classes: periodical vibration and random vibration.

To submit devices to periodic vibration is the main cause of failure. The simulation of such periodical disturbances by laboratory sine excitation has been frequent for failure or durability tests as well as diagnosis tests. The simulation of in service periodical vibration is explained since the damage in objects by sine vibration is due to magnified effects of resonance.

The natural frequencies of the test specimens should be evaluated in order to perform fixed frequency vibration tests. These tests are performed for each of the natural frequencies of the test specimen in turn. Such tests could be used to evaluate the fatigue strength when subjected to resonance frequencies, or evaluate the structural damping ratio and investigate equipment noise sources on, for example, appliances or other structures. The devices used for vibration test on fixed sine frequency are quite simple since the input signal to be amplified could be obtained, for example, by a simple signal generator. Some auxiliary equipment are also useful like those for vibration amplitude control, devices for coil displacements and acceleration measurements and devices for quickly move the shaker's table in order to simulate pulse damped vibrations.

The sine sweep vibration test could be used to adequately simulate the damage growth (often due to unbalancing). Since the frequency is swept through a large band frequency, most of the resonant vibration modes can be excited and evaluated accordingly its severity. These tests are used for terrestrial vehicles, vessels and aircrafts since these tests sweeps each frequency sequentially at a low cost.

The random vibration induced by jet engines related to top aircraft flying has demanded new design criteria and new test procedures to assure the reliability of devices on such environment. When the random vibration is measured on field this signal can be used as boundary parameter to define reliability criteria to be reach. Sometimes the actual acceleration signal of a working environment is not the most suitable way to characterize this vibration and latter be used on a shaker or exciter system. In addition there are other intervening factors that shows these signal will not probably be reproduced again since there is presented some level of randomness. One of the best ways to detail this type of signals is by the Acceleration Power Spectral Density (PSD) obtained from an actual acceleration. This PSD is defined by frequency bands of the whole interested frequency domain. So it is provided plots of Acceleration PSD and frequencies.

There are many Standards dealing with the dynamic tests (each company or supplier specifies its own minimum requirements). However it is notice that there is a global trend in using Acceleration Power Spectral Densities as a standard for random vibration tests.

The Acceleration Power Spectral Density can be evaluated by the Fourier Transform of the desired signal auto-correlation. In other words:

$$S_a(\omega) = \frac{1}{2\pi} \int_{-\infty}^{\infty} R_a(\tau) e^{-i\omega\tau} d\tau \quad (1)$$

where $R_a(\tau)$ is the acceleration auto-correlation function, i is the imaginary number, ω is the frequency in rad/s units and τ is a time separation lag. The autocorrelation function $R_a(\tau)$ could also be evaluated by:

$$R_a(\tau) = E[a(t)a(t-\tau)] = \lim_{N \rightarrow \infty} \frac{1}{N} \sum_{r=1}^N a_r(t) a_r(t+\tau) \quad (2)$$

where the symbol $E[.]$ represents the mean value, $a(t)$ means the acceleration time history and N means the sample size. Volkswagen Standard AG 801-01(2004), describe a important characteristic of the auto-correlation function for zero mean processes is that: $R_a(0) = \sigma_a^2$, and so it is also valid the relation:

$$\sigma_a^2 = \int_{-\infty}^{\infty} S_a(\omega) d\omega \quad (3)$$

In other words, the acceleration process variance is the area below the Spectral Density, or the value of $R_a(\tau)$ on origin.

The Standards generally specifies Power Spectral Densities on its one-sided form, i.e., they are specified of positive frequencies bands. As stated by Eq. (1), the Power Spectral Densities definition uses infinity upper and lower limits, so the One-sided Power Spectral Densities are defined as indicated by Eq. (4):

$$G_a(\omega) = 2S_a(\omega) \quad (4)$$

For the pseudo-acceleration signal generation it could be used sine series as indicated by Eq. (5):

$$a(t) = \sum_{i=1}^N (\sqrt{2S_a(\omega_i)\Delta\omega}) \cdot \sin(\omega_i t + \varphi_i) \quad (5)$$

Where the Power Spectral Density was divided by N frequency intervals $\Delta\omega$, and the phase angles φ_i are random values for each centre frequency band ω_i , so the process is supposed to be a superposition of sine periodical processes with uncorrelated phase angles.

3. METHODS AND EQUIPMENTS

3.1. Equipments

The used equipments for this paper are listed below. They are part of the GMAP (Grupo de Mecânica Aplicada) laboratory equipment in the Federal University of Rio Grande do Sul:

- Shaker: TIRA Vibration Test Systems, Germany, model St. 5000/300.
- Range frequency: 20 Hz to 5kHz;
- Maximum displacement: +/- 6 mm;
- Maximum applied load: 2940N;
- Total device mobilized mass: table + armature + fastening devices: 8.5kg;
- Internal electrical resistance: 4 Ω ;
- Accepted Maximum Power: 500W (RMS);
- Maximum tested specimen mass: 60 kg.
- Signal Amplifier: WATTSOM, model DBK 6000;
- Number of amplifier channels: 2; Output power by channel: 350W (AC: 230V); Amplifier class: AB; Frequency response: 15Hz to 40kHz; total harmonic distortion + noise (THD+N) in 8 Ω : <0.05% from 20Hz to 1kHz and <0.1% from 20Hz to 20kHz; Input impedance (unbalanced): 20 k Ω ; Signal to Noise ratio(without weighting): >90dB.
- On board Sound Card Realtek ALC650/AC'97, Signal to noise ratio >90dB, 6 channels, 18 bits for ADC and 20 bits for DAC, Input and Output limits: $\pm 1.5V$ and working frequency range 20Hz to 48kHz for output and 1000Hz to 8000kHz for input.
- Data Acquisition, Signal Processing and Signal Sending Software: AgilentVee 7.5;

The used accelerometer was of the MEM type (capacitive) produced by the Analog Devices. It has an maximum output voltage of 2.5 V for 50g peak acceleration. The model is the ADXL 250 that measures +/- 50g in two orthogonal axis and has a sensitivity of $S=76mV/g$. Figure 3 shows the way the equipment is connected.

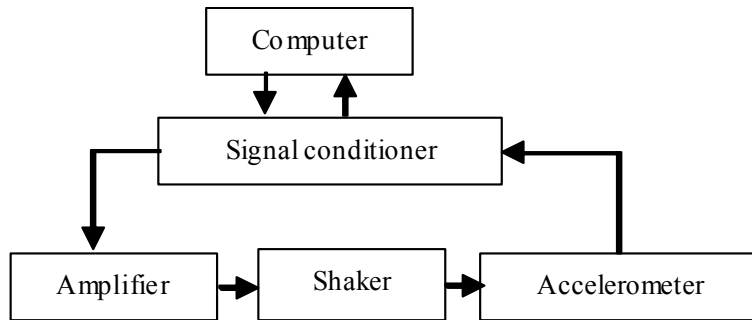

Figure 3. Closed Loop Scheme for the Active Control

3.2. Methodology

Most of the vibration test Standards defines the vibration experiment by an Acceleration Power Spectral Density. The unit of such variable is stated as $(m/s^2)^2/Hz$, versus frequency (see Fig. 2). Based on the measured acceleration, one can plot the Power Spectral Density and thus compare the total energy of the signal generated, for example, by a shaker and the Standard. These comparisons may be done by spectral bands or by octave bands. In this way, it is possible to evaluate a updated correction weight for each band frequency of the shaker output in order to match the desired PSD.

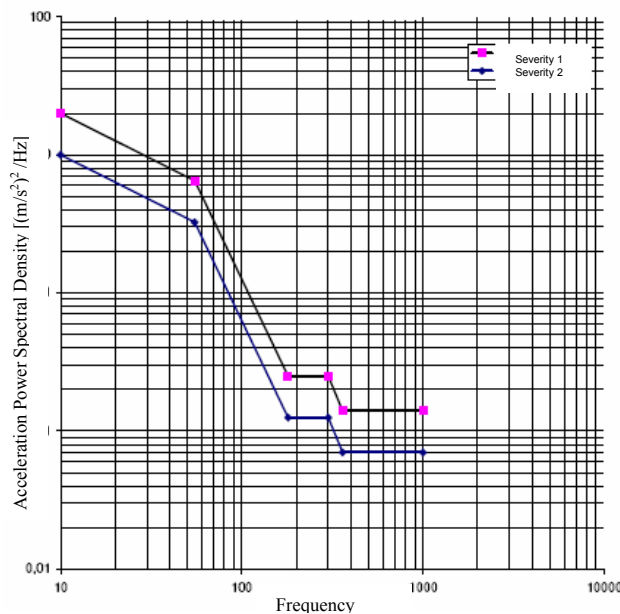

Figure 2. Plot for Acceleration Power Spectral Density *versus* frequency (Volkswagen Standard, 2004)

The area below the Power Spectral density and the frequency axis defines the RMS acceleration value. This parameter is important since it this variable is used by the test Standard as a check parameter for the generation. In the above Fig. 2, the severity curve 1 has an acceleration RMS value greater than the severity curve 2.

This method used in this paper is based on a closed loop scheme, so the acceleration is measured by an accelerometer on the shaker's table at the same time it is compared with the desired acceleration (RMS value). It is also compared the one-sided Power Spectral Density. If these values are different for the frequency band, the developed software weights this band in order to compensate this behaviour. It is accomplished iteratively throughout close loops, acquiring and sending voltage signals till the discrepancy are negligible for each of the frequencies bands (Fig. 3).

The used frequency bands follows the well known procedure to work with octave or 1/3 octave bands in order to quickly sweep the frequency range. This implementation was based on specific Standard that requires the generation of PSD in the 10Hz - 1 kHz range.

After some iteration, the developed system behaves as an open loop system and continues to generate signals from the last converged iteration.

In order to estimates mean characteristics of the used shaker, it was evaluated the following response curves:

-Acceleration *versus* frequency;

- Velocity *versus* frequency;
- Displacements *versus* frequency;
- Acceleration *versus* input voltage.

It was noticed that the relation input voltage *versus* acceleration follows a linear trend. As indicated by Fig. 4, and that the shaker's acceleration *versus* frequency follows a non-linear trend. This last result was expected since the input power was kept constant for changing frequencies.

2. PRELIMINARY RESULTS

Analyzing the obtained response curves, it was noticed that the system could be approximately supposed to act linearly from 100Hz to 1000Hz. The iterative software could handle differences originated by this assumption (outside the frequency range from 100Hz and 1000Hz) weighting appropriately the frequency bands. Figure 3 indicates typical relationships between acceleration and frequency with the same input voltage.

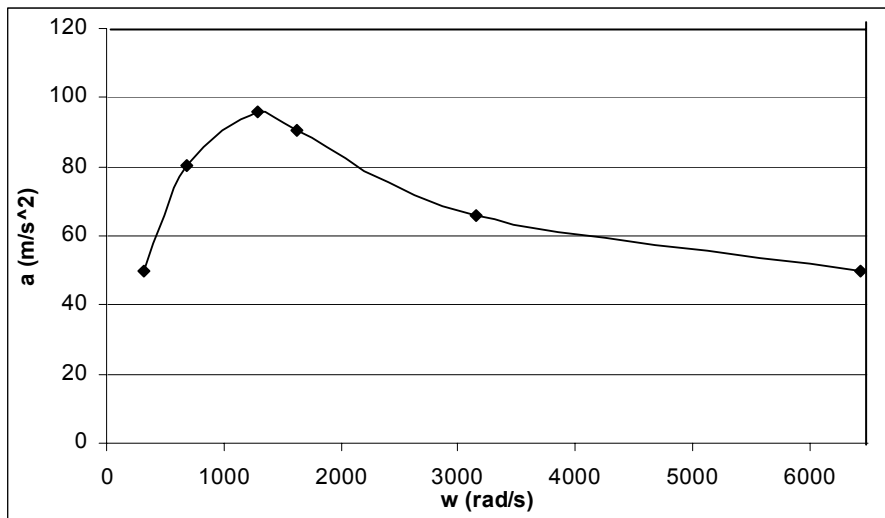

Figure 3 - Typical Acceleration x Frequency curves for the shaker.

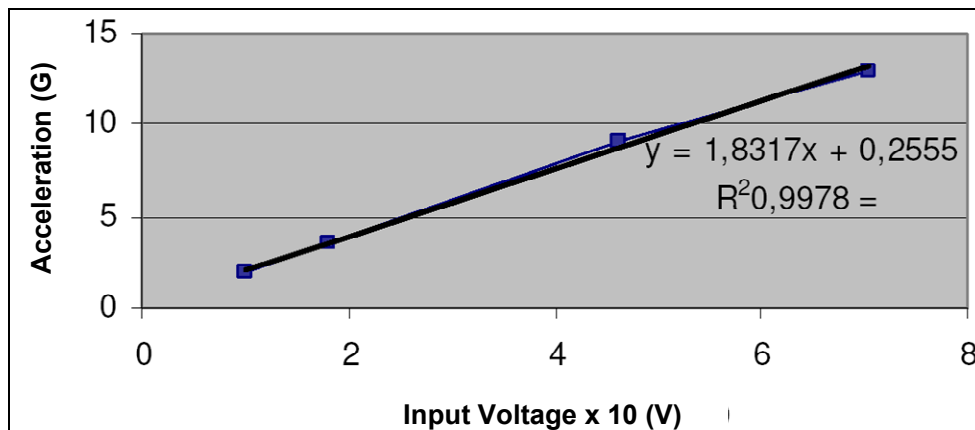

Figure 4 - Typical plot for amplifier voltage output versus measured acceleration on shaker's table (without test specimen)

Using Fig. 3 and Fig. 4 it is possible evaluate curve fitting parameters for voltage to acceleration and vice-versa. These parameters were used as a start point in the first iterations of the software since there were no correct values. After some iteration the system gather information and evaluate weights to correct the output signals so the respective curves became useless.

The software was developed based on AgilentVee 7.5 platform. It allows selection by the user the acquisition time, acquisition sample ratio and selection of tasks like as sending signals or (sending and receiving signals) for the evaluation of corrections weights, selection of the desired PSD from database as indicated by Fig 5.

The software shows a graphical interface for the user with PSD of the measured acceleration and Standard values. It also shows RMS of acceleration, evaluated weighting factors at each iteration step (Fig. 5). The weighting factors are recorded on files along iterations and later used for sending the corrected desired PSD. The values of the last cycle are used for this purpose.

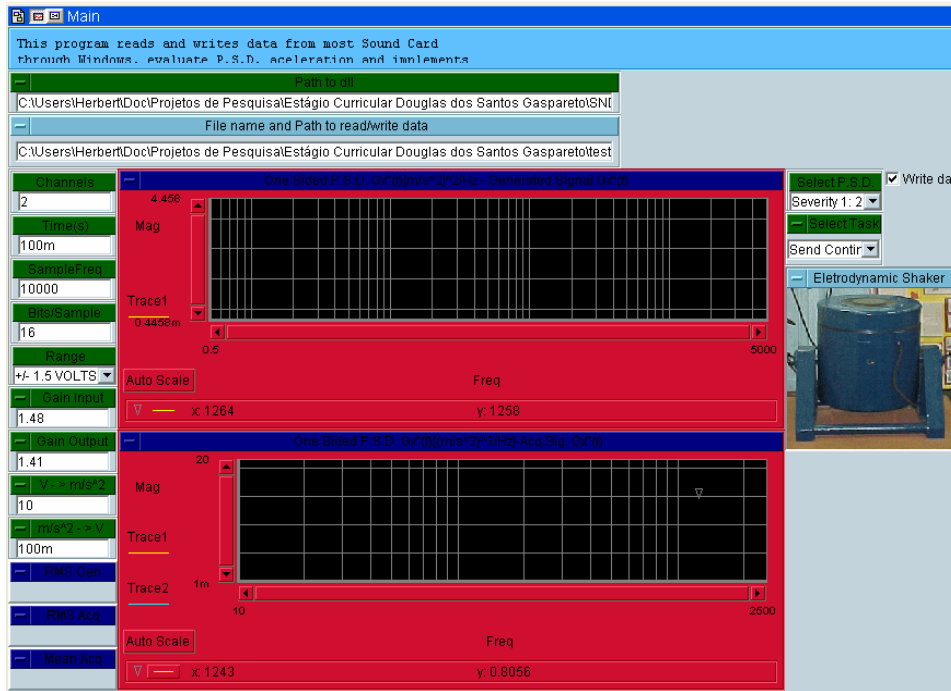

Figure 5. Graphical User Interface for the developed software

For single frequency vibration tests of 500Hz and acceleration amplitude of 1m/s^2 (0.707 m/s^2 RMS), the following plot (Fig. 7) shows the experimental results at the 10th cycle of iteration with the corrected one-sided acceleration PSD (upper yellow plot) and the acquired one-sided acceleration PSD (lower plot with the Standard in yellow and the measured in blue). The RMS value of acceleration is shown at the bottom left corner with a value of 0.704 m/s^2 .

Figure 8 shows the 15th iteration for the corrected one-sided acceleration PSD (severity level 3, 13.9 m/s^2 RMS) to take into account non-linear behavior of the shaker (upper yellow plot) and the acquired one-sided acceleration PSD (lower plot with the Standard in yellow and the measured in blue). The RMS value of acceleration is shown at the bottom left corner with a value of 8.63 m/s^2 .

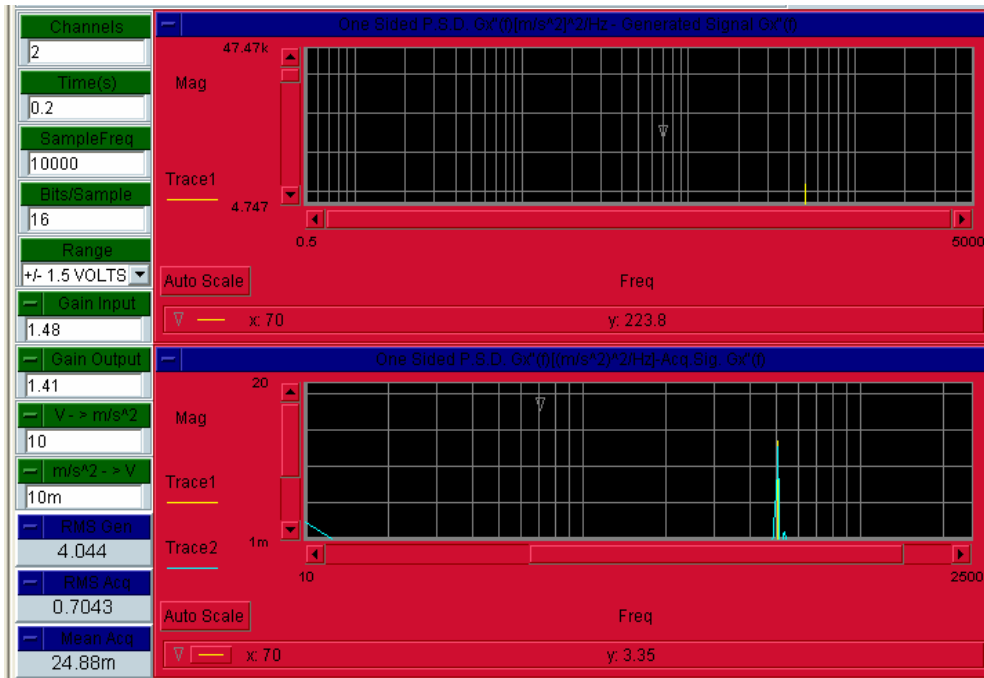

Figure 7. Acceleration PSD for single sine at 500Hz and acceleration amplitude of 1 m/s² (0.707 m/s² RMS)

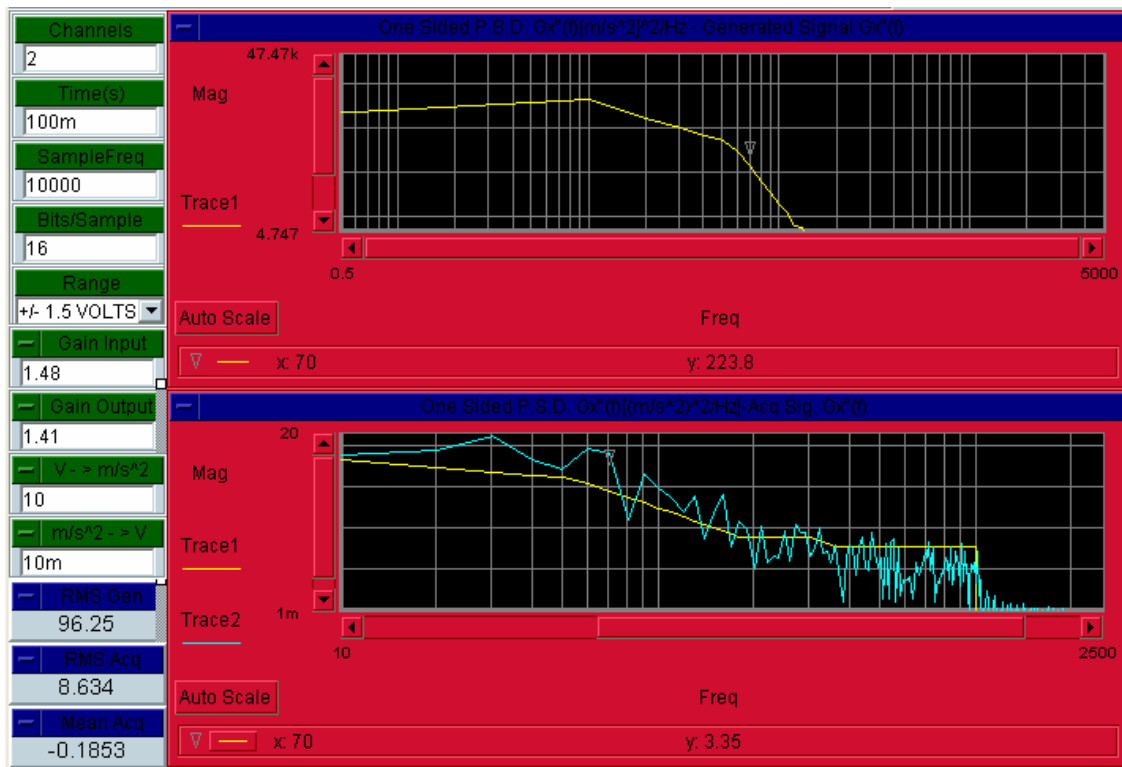

Figure 8 - Acceleration PSD for random vibration test with severity level 3 (13.9 m/s² RMS acceleration) (Volkswagen Standard (2004))

4. CONCLUSIONS

The conducted experiments have shown that with low cost and effort it was possible to develop a closed loop active acceleration control of an electrodynamic shaker. The operation of the system starts acquiring acceleration signals from the shaker's table due to input voltage signals sent to the shaker. Later the system behaves as a single open loop just

sending weighted voltage signals to the shaker. The results and software used in this paper can be used on other shakers with different load capacities since the PSD comparisons and weighting correction accounts for non-linearities present in the system. This approach avoids difficulties related to the traditional control in evaluating system parameters, like stiffness, damping, mass, transfer functions, etc, and its implementation is very simple and straight. The displacements control, which was neither implemented nor investigated here, could be used to improve the system performance, mainly for low frequencies, however with a higher cost. This could improve some noticed differences between generated and desired acceleration PSD on above Figures.

3. ACKNOWLEDGEMENTS

The authors' wish acknowledge the GMAp laboratory for the Shaker and equipments used in this work. The authors are also grateful for the Brazilian Councils CNPq and CAPES for the financial support and involved scholarships.

4. REFERENCES

- Cavaliere, H. M., Cavalca, K. L., 2004, "Desenvolvimento e Implementação de um Programa para Geração de Sinal de Alimentação de Excitador Eletromecânico (Shaker) em Plataforma Labview" (In Portuguese) , XXII Congresso Interno de Iniciação Científica da Unicamp, setembro, Brazil.
- Flora, L. D., Gründling, H. A., 2006, "Acceleration Control of an Inverter-Fed Electrodynamic Shaker", In Proceedings of the 37th IEEE Power Electronics Specialists Conference, Jeju, Korea , pp.2799-2805.
- Fugita, M., Uchiyama, Y., 2005, "Robust Acceleration and Displacement Control of Electrodynamic Shaker". Internal Report, Department of Mechanical and Control Engineering, Tokyo Institute of Technology, Tokyo.
- Moutinho, C., Cunha, A. and Caetano, E., 2004, "Controlo Activo de uma Plataforma Vibratória para Excitação Sísmica de Modelos Laboratoriais", (in portuguese), In Proceedings of the SÍSMICA 2004 - 6º Congresso Nacional de Sismologia e Engenharia Sísmica, Portugal, pp.611-620.
- Newland, D E., 1984, "An Introduction o random vibrations and spectral analysis", Longman Scientific & Technical, Ed. John Wiley & Sons, Inc., New York, 375p.
- Salehzadeh-Nobari, S., Chambers, J. A., Green, T. C., Goodfellow, J. K. and Smith, W. E. D., 1997, "Implementation of Frequency Domain Adaptive Control in Vibration Test Products", In Proceedings of the 5th International Conference on Factory2000, No. 435, Imperial College, England, pp.263-268.
- Uchiyama, Y., Mukai, M. and Fujita, M., 2006, "Robust control of electrodynamic shaker by 2DOF control using H_∞ Filter". Internal Report, Department of Mechanical and Control Engineering, Tokyo Institute of Technology, Meguro-Ku, Tokyo.
- Volkswagen Standard AG 801-01/ No. 8M A0 0, 2004, "Eletric and Eletronic Assemblies in Motor Vehicles: General Test Conditions". July, 46p.

5. RESPONSIBILITY NOTICE

The authors are the only responsible for the printed material included in this paper.