

MODELING AND ANALYSING OF THE MATERIAL ENTRY FLOW SYSTEM IN A PICKLING LINE PROCESS USING PETRI NET

Marília Gabriela Viana Nassar
COSIPA , Cubatao, SP, BRAZIL
marilia@cosipa.com.br

José Isidro Garcia Melo
University of São Paulo, Escola Politécnica, São Paulo, SP, BRAZIL
University of Valle, Faculty of Engineering, Cali, CA, COLOMBIA
joisigar@poli.usp.br

Paulo E. Miyagi
University of São Paulo, Escola Politécnica, São Paulo, SP, BRAZIL
pemiagi@usp.br

Diolino dos Santos Filho
University of São Paulo, Escola Politécnica, São Paulo, SP, BRAZIL
Centro Universitario Fundacao Santo Andre, Santo Andre, SP, BRAZIL
diolino.santos@poli.usp.br

Abstract. *Over the last decades, manufacturing systems have been object of interest of many professionals and researchers interested in new control techniques for improvement of productivity and managerial competitiveness. Among these systems, the material entry flow in a line process deserves special attention since it is responsible for the maintainance of continuous material flow of the process. In this context, this work introduces a procedure for modeling Material Entry Systems (MES) in a pickling line. Considering the materials flow system as Discrete Event System (DES), techniques derived from Petri Nets can be used for modeling purposes. Such techniques include the Production Flow Schema and the Mark Flow Graph (PFS/MFG), which have been proven efficient for hierarchical modeling, analysis and control of DES. In this context, the MES is approached in different levels of abstraction: a conceptual model which is obtained by applying the PFS technique and a functional model which is obtained by applying MFG. The proposal confirmed to be useful and efficient to material entry flow system modeling, when allowing the functional specification of the whole system (object of control and control system), and strategies that facilitate its integration with all line production process.*

Keywords: *Petri Nets, Discrete Events System, Procedure for Modeling, Pickling Line Process.*

1. Introduction

Productions systems, as part of organizational socio-economic structures, have being object of a continuous transformation regarding new standards based in principles of quality, competitiveness, innovation among between others (Chen C.,Dai 2004). In addition, important factors as the crescent enterprise competitiveness and the economy globalization have contributed to increase the market heterogeneity level of evolution that, consequently, constitute in one of the most important challenge for the industrial sector. This fact calls for a posture by the enterprises to be able to manufacture different products involving shorter lifecycle (Zurawski and Zho, 1994).

In case of siderurgical industry, the requirements of the products with strict features, e.g., lower thickness, high quality, lower costs and crescent market competitiveness has motivated the continuous improvement of the mill process and process reliability. As a result, the system presents more complexity in interactions motivating the use of news control strategies (Aeberli et al., 2000).

In the pickling line process, a mechatronic approach is used to integrate a great variety of equipments such as levelers, electrical energy source, welding machine, shears, and acids tanks. The purpose of this interaction is to assure a continuous production flow that is a key factor for high efficiency, productivity and product quality (Deisenberger, Kutschar 2003).

One important sub-system of the pickling line process is the material entry system (MES). The following are main purposes of the MES;

- Take off the imperfections of the production process in the beginning (head) and ending (tail) of the sheet that are received in coil package;
- Through of the welding process, assure the continuous flow production making the union between sheets.

Thus, the functional efficiency of the MES must be object of careful analysis in function of its influence in the mill productiveness as a whole, assuring the continuous flow process due complexity of the MES, in this sense, a suitable modeling is important to validate and verify the functional behavior of system and its integration with the others systems.

The programmable logical controller (PLC) is an essential equipment in implementations of industrial control system, and standardizations have being defined (IEC 61131, IEC 499). These standardizations represent a relevant step for development of control system, however they are insufficient to verify and validate control strategies. In this context, in Frey and Litz (2000) are showed several reasons for application of formal method for PLC programming applications, such as:

- The growing complexity of the control problem, the demand to reduce development time, and the possible reuse of existing software modules.
- The demand for high quality solutions especially for safety critical condition needs verification and validation procedures.

In the Figure 1 a generic model of the logical control design process is showed, (Frey and Litz 2000). Without the use of formal method, the controller design process consists of the outer ring: The realization of logic controller is derived only from informal specification by direct implementation and afterward it is informally validated against the informal specification. The term “informal” refers everything that is not based on a strict composed, systematically and semantically well-defined form.

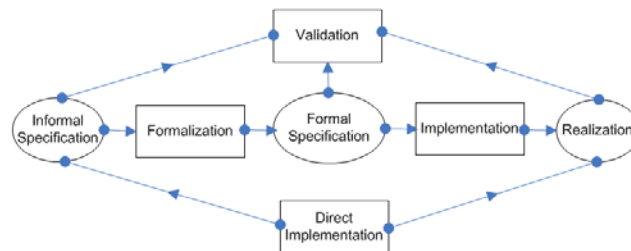

Figure 1. Control design process.

In Mader and Wupper (2000) are presented important considerations for utilization of formal method in control application. In this work is evidenced that systems, as MES, can be treated as discrete event systems (DESs) and techniques such as Petri net (PN). In Peng and Zhou (2004), a review of recent works about methods based in PN for modeling, analyzing and implementation of system control is developed, exposing the efficiency use of this technique as tool in control system area. In this context, this work evidences a procedure to modeling the MES considering its integration with other parts of a line production system. The work considers the theory of discrete event system (DES) to realize the modeling. In this sense, this work provides a procedure for the design, specification, validation and verification of entry flow system in a pickling line process.

The approach adopted in this work is based initially in the process system characterization and the application of Petri net derived techniques, such as Production Flow Schema (PFS) (Miyagi 1996), and Mark Flow Graph (MFG) (Miyagi 1996) for the model construction and analysis. The model generated is validated in accordance with the MES requirements and it is verified through with the PN proprieties (Reizig 1985; Murata 1989; Peterson 1981).

The organization of the paper is as follows, in the section 2, are presented the main functions and features of a pickling line process. In the next section is presented the Petri net derived technique. Then, the procedure for modeling of MES is discussed, in the section 5 is presented a case study where the procedure is applied. Finally, in the last section is presented the conclusions of this work.

2. Pickling Line System

The main purpose of a pickling line process is to remove the oxide layer formed in the steel surface during the hot mill. This layer is removed by a chemical reaction between the oxide layer and the acid bath. The pickling line processes involve a hydrochloric acid reaction that is represented for the following expression:



In the pickling line systems (PLS), Fig. 2, the steel strips in coil packing form to be pickled are taken from a local denominated “relief storage” with a lift truck. Then, the coil is put on the line transporter, with a guider. The coils are uncoiled on the uncoilers devices, and the strip pass through to the leveler. In the double shears of rough-cut, the beginning (head) and the ending (tail) of the coil are cut. After the rough cut, the thin cut shear prepares the sheet roof for the weld. The main purpose of the welding machine is to maintain the continuity of the process, welding the roofs of the sheets. After of union by welding, the trip passes for the tension roll, going to the entry accumulator’s cars and coil centralization devices. Thus, the sheet passes in the pickling tanks where the chemical process occurs. Before getting out of the pickling tanks, the sheet pass on the dryer rolls that block the water passage. After, the sheet passes by the dryer and has again a new accumulation and centralization actions. The function, in this step is to accumulate the material that is getting out of the tanks during the stop for the ending cut of the sheet. The width of the sheet is defined by lateral shear. The oil machine promote the sheet oiling only on the superior surface, on the exit shear, the sheet is cut when it reached the right end length of the coil, on the coiler, the sheet is coiled forming the final product of the process.

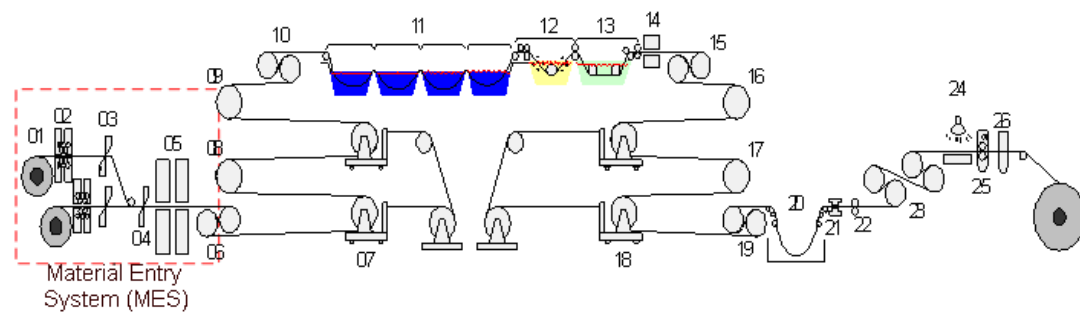

- | | |
|----------------------------|------------------------------|
| 1- Uncoiler | 15- Bridle roll 03 |
| 2- Leveler | 16- Coil centralization 03 |
| 3- Rough cut shear | 17- Coil centralization 04 |
| 4- Thin cut shear | 18- Exit accumulator Car |
| 5- Welding Machine | 19- Bridle roll 04 |
| 6- Bridle roll 01 | 20- Exit tank “loop” |
| 7- Accumulator car | 21- Notcher |
| 8- Coil centralization 01 | 22- Side trimmer |
| 9- Coil centralization 02 | 23- Bridle roll 05 |
| 10- Bridle roll 02 | 24- Inspection quality table |
| 11- Hydrochloric acid tank | 25- Oil Machine |
| 12- Cold water clean tank | 26- Exit shear |
| 13- Hot water clean tank | 27- Coiler |
| 14- Dryer sheet | |

Figure 2. Layout of pickling line system with 2 uncoilers.

The dynamics behavior of the PLS is defined through changes on the discrete states due to event’s occurrences considered instantaneous, e.g., activation and deactivation of presence sensors and manual commands, turn on and shut down of motors, opening and closing of cylinders. The class system defined by this behavior is called discrete event system (Ramadge, Wonham 1989; Miyagi, 1996). Many technical for these modeling, analyzing, control and design have been developed. Among them stand out the Petri net, Markov chain, queue theory, state machine, mini-max

algebra, etc. in particular, Petri net proved to be reliable and efficient tool in industrial applications (Peng and Zhou 2004) (Zurawski and Zho ,1994)

3. Petri Nets and their extensions for EFS

Since its presentation in 1962 by Carl A. Petri, the Petri net (PN) has been considered as a powerful tool to modeling, analysis and design DESs. This tool allows a graphical and mathematical description of the system. In this way, the PN is a communication tool among people related with the project, allowing an easy interpretation, clear identification of the states and actions. The PN offers the possibility of dynamic representation of the system and its structure in many levels of abstraction. PN can represent process with synchronism, concurrent, causality, conflict, and share resources. The mathematical support of PN is useful for realization of formals tests of the dynamic proprieties of the system. This is especially useful in the application where the security is a relevant factor. A formal definition, rules of the execution and formalization of the dynamics proprieties of the PN, are presented in (Reizig 1985; Murata 1989; Peterson 1981).

Figure 3 shows some of the main characters of de DESs related to MES. On the process synchronism (Fig 3a) the “Welding” only can initiate when the “Head Preparation” and “Tail Preparation” are finished. In the parallel process (Fig 3b) after the “Fusion Welding” is finished the “Up Head Block” and “Up Tail Block” are activated simultaneously. In the conflict situation (Fig 3c), after that the coil is mounted in the “line transportation” the system can execute the “Uncoiler load 1” or “Uncoiler Load 2”. Finally, in the sequence process (Fig 3d), the process “Head Strip Cut” is initiated after that the process “Up Table” is finished.

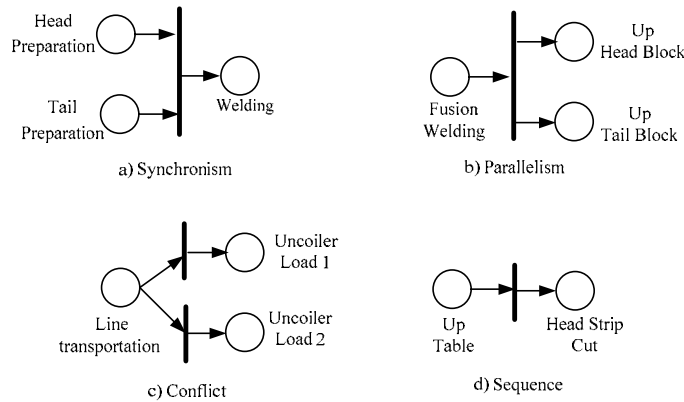

Figure 3. Characteristics of SEDs.

In this work, PFS/MFG (Miyagi, 1996) is considered to modeling the MES. This technique consists in the system modeling following a systematic and rational procedure based in the structure hierarchical interpretation and system functions. Initially the conceptual system modeling (representing a high system level of abstraction without its dynamic detailing) is developed through PFS. In this step, the purpose is modeling the main function characters that will be considered in the system, as soon as the items flow (material and/or information) among the main activities. To describe the dynamic system behavior, the model in PFS is converted gradually in a MFG, that is, an interpreted Petri net that detail the dynamical behavior of the system.

The structural elements of PFS are represented in the Fig 4. They are: a) activity (active component), represented by the blocks which characterize modifications on the flow of items; b) Inter-activity or distributor (passive component) represented by a circle which do not modify the items and c) oriented arc (flow of materials and/or information) represented by arrow between the inter-activity and a activity or vice-versa. The PFS has not marking, because it is a conceptual system model. A detailed description of the PFS is in Miyagi (1996).

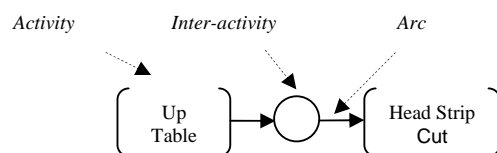

Figure 4. PFS structural elements.

Structures elements of the MFG (boxes, temporized boxes, inhibit and enabled gates, transitions, temporized transitions and arcs) are illustrated in the Fig 5. In the MFG there exist the explicit representation of external elements and the mark concept (marks distribution and transitions fire rules) to reflect the state system. A detailed definition of the MFG and its extensions are in Miyagi (1996) and Takahashi et al. (1999). An example of MFG and its structural elements is showed in the Fig 5. In this example, the system is initially in stand by condition, represented by a mark in the box “Stand by”.

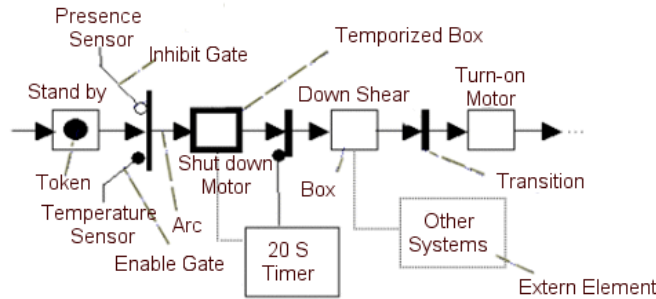

Figure 5: Example of MFG Model and its structure elements.

When the system receive the sign from “Temperature Sensor” and the “Presence Sensor” does not activated, the “Shut Down Motor” is activated, that is, it is expected the device to be effectiveness activated. This process of shut down the engine has duration of 20 seconds after the initiated procedure. After a specificity time, the “Down Shear” is activated, sending a sign to pre-defined “other systems” and as following the “Turn on Motor” is activated.

4. Modeling procedure of the Material Entry System

This procedure proposed for modeling the MES is composed of five steps which are illustrated in the figure 6, and detailed as follows:.

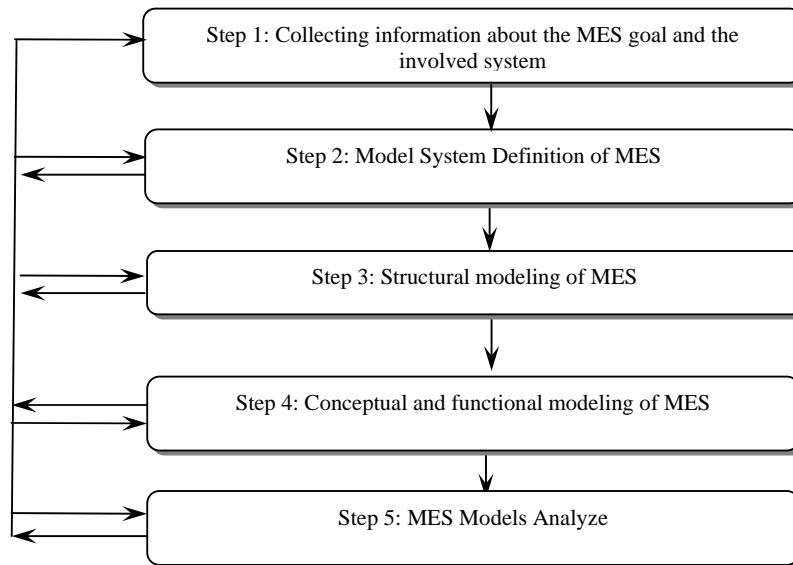

Figure 6: MES modeling procedure.

Step 1: Collecting information about the MES goal and the involved system.

This is the initial stage of the MES modeling. In this step a research is carried out with the purpose of collecting information about the pickling and welding processes. Additionally, standards, recommendations of the process and equipments parameters available are studied. This information is used to perform a preliminary analysis and

identification of relevant data for modeling procedure. These dates will allow characterizing the system behavior in a quantitative and qualitative form.

Step 2: Model System Definition of MES

In this step, the collected information in the step before are processed, and the MES requirements are established. A careful evaluation and analysis of the information must allow the identification of problem interpretation and verification of the new raisings, case the information is not sufficiently clear or there exist contradictory or incorrect interpretation.

In this step, the following information is identified: (a) what are the necessary procedures to attend the process specifications; (b) what are the devices used in each step procedure; (c) the flow of information that is involved in the MES's activities.

Step 3: Structural modeling of MES

This stage consists of developing the MES structural model. The physical devices and sub-systems are identified considering the architecture adopted to control system. Basically, the MES is represented by the interconnection of two important subsystems: the controlled object and the control system.

The documents generated in this stage are: (a) MES structural diagram, (b) identification the control devices, (c) Identification the detection devices, (d) Identification the actuation devices, (e) Identification the monitoring devices, (f) Identification the manual command devices. This information is the base to carry out the model of system in step four.

Step 4: Conceptual and functional modeling of MES

In this step, a modeling of each structural element system is developed systematically according to hierarchal approach. Initially, the conceptual model is developed then it is gradually refined until the functional model is obtained.

The conceptual model of system is especially important to deal interpretations of acquired information in previous stages that could be subjective. In addition, it helps to ideas organization and permits descriptions and understands of different component, interrelations and functions. In this stage, The PFS/MFG methodology is adopted (Miyagi et al, 1997).

The functional model contains the dynamical descriptions of system. The models are then analyzed in order to verify if they satisfy the specifications of the MES in such way that its dynamic behavior should be equivalent to the expected behavior.

Step 5: Models Analyze.

Afterwards, MES functional models are obtained. In this step, a behavior analysis is carried out to evaluate different scenarios and measurement of performance the MES functionalities and their interactions with other systems are studied. Verification can be conducted by simulation or through formal analysis of MFG model based in the properties of PN (Reizig 1985; Murata 1989; Peterson 1981).

5. Application Case

Due to the limited space available just a sample of some results obtained in the developed stages are presented in this section. The application case used to illustrate the procedure proposed is the MES in the pickling line of COSIPA (www.cosipa.com.br) a metallurgy company located in Cubatao , SP, Brazil.

Step 1: Collecting information about the MES goal and the involved system.

This stage was developed reviewing of the available documentation process, bibliography, and visual observation of process. In addition, different meeting with professional involved in the process operation was carried out.

Step 2: MES Definition

Table 1 shows the temporal parameters of main activities in the MES. In this sense, the systems must send the signal to different actuation and monitoring devices and receive signals from different sensors to attended the temporal specifications, if these time restrictions are not attended, the systems control must send a alarm signal and stop the MES, it is important to note that this work does not deal with detection, diagnosis and treatment of faults and supervisor level. Theses aspects will be included in future works.

Table 1: Temporal parameters

Activity	Time(seg)
Tail Preparation	120
Head preparation	180
Welding	15
Set up the welding machine	120
Sharp Edge	30

Step 3: MES Structural modeling.

This stage identifies the components of the MES in two groups, those that belong to the control system and others that belong to the controlled object. The controlled object in this example includes the machinery where the different activities are developed; the control system includes devices such as sensors, actuators, alarm, monitoring and controllers, involved in control actions. A layout of MES is presented in the Fig 7

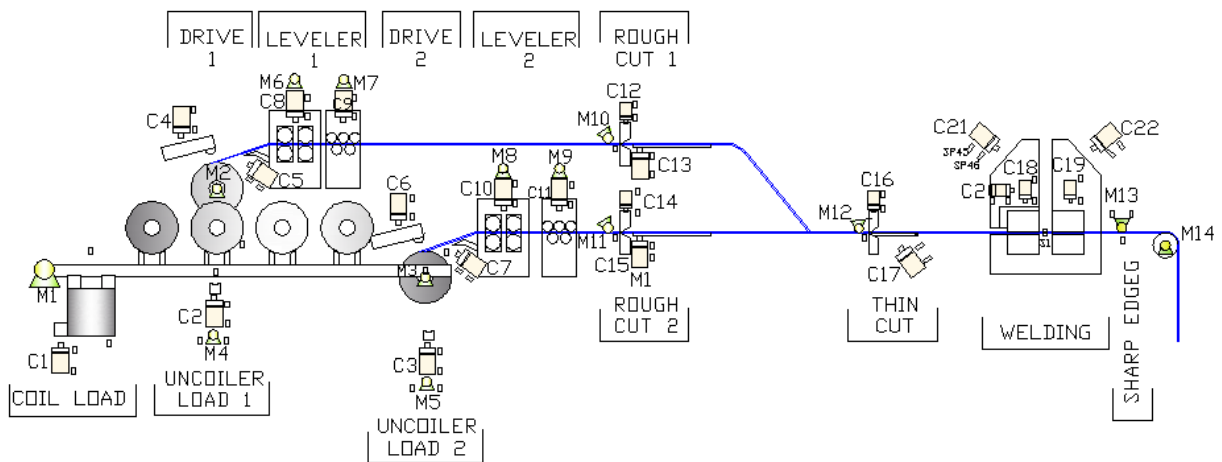

Figure 7. Layout of MES.

Devices	Description	Symbols
Command devices	selection modes, manual controls	SM, CM
Detection Devices	1 temperature sensor, 60 presence sensor , 1 distance sensor	T, SP, SD
Actuation Devices	14 motors, 22 hydraulic cylinders, 1 engine	M, C, S
Monitoring Devices	10 lighting alarm, 5 loud alarm, 3 HMI	A, AA, HMI
Realization control devices	3 CLP, 2 PC	PLC, PC

Step 4: Conceptual and functional modeling of MES

The conceptual and functional models are developed according to information acquired from MES, the conceptual modeling considers each one of the structural system elements in a top down approach. This modeling is performed using the PFS, MFG and its extensions.

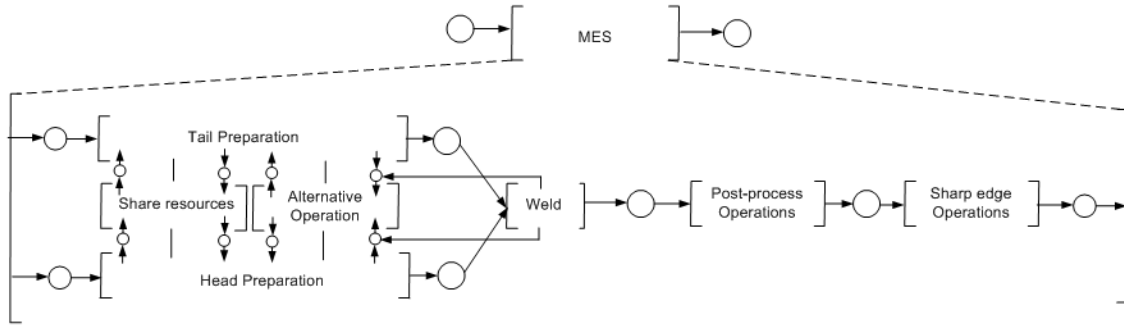

Figure 8. Example of PFS model.

Figure 8 shows a general PFS model of MES. In this model, the “Weld” can be initialized only when “Tail preparation” and “Head preparation” are ready. Both, “Tail preparation” and “Head preparation”, need consider the availability of shared resources and alternative operation to develop the activity. Then, when the “weld” has finished, sequentially, the “Post- process operation” and “Sharp edge Operations” are developed.

Figure 9 shows a PFS model where the conceptual model of the “Head Preparation” activity is refined. In this activity, initially, it is developed the “load transportation line” activity, where the coil begin the pickling process, then, depending of the availability in shared recourses and setup of alternative operation, information sent of “Share recourses” and “Alternative operations” activities, “Rough preparation 1” or “Rough preparation 2” are developed, this activity fundamentally consists of loading the uncoiler machine and the rough cut of the beginning (head) of the coil. When this activity is terminated, the “thin preparation” is activated, to assure the success fit of sheet (head and tail) to weld.

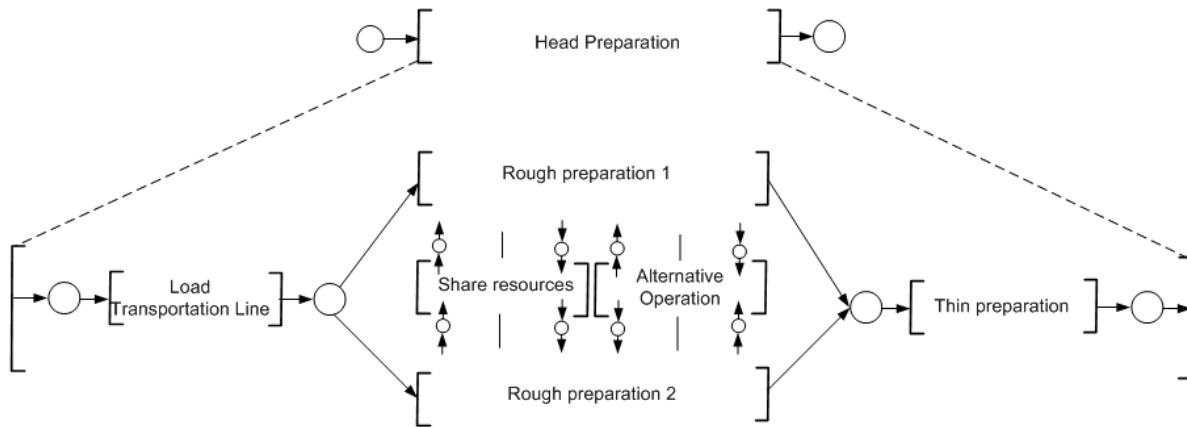

Figure 9. PFS Model of the activity “Head Preparation”.

The dynamic behavior description of “Load transportation line” activity is developed in MFG (Fig. 10). In this activity, the presence sensor of initial position of guider line, SP1, which assures the correct initial position of guider, the presence sensor of coil, SP3, which indicates that the coil is ready to begin the pickling process, and the presence sensor of coil, SP4, which guarantees a correct mount position of coil in the transportation line needs to be in activated state to shut down transportation line, M1. Following, a rotation of guider is developed, C1+, to reach a final position which is detected for a presence sensor, SP2, when the coil has to be mounted on the transportation line, the guider must be back to initial position, detected for sensor presence, SP1, and finally, the motor of transportation line is turn on.

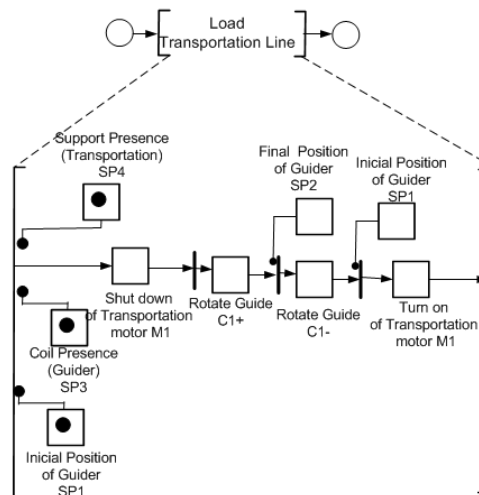

Figure 10. MFG model of "Load transportation line" activity.

Step 5: MES Models Analyze

The state space of MFG models is then generated, to validate and verify the functional correctness of MES. Through the constructed state space, behavioral properties of MES were verified. Examples of such properties are the absence of deadlock in the MES, the possibility of always reaching a given state, and the delivery guarantee of a given service. The HPSim tool (Anschuetz, 2001) was used to MES models simulation, to validate it.

6. Conclusions

This paper introduces a procedure for the modeling of MES. The MES is considered as Discrete Events Dynamic System, and in this sense, the proposed procedure is based on interpreted Petri net. This procedure allows the structured development of models, facilitating the modeling process and upgrading of MES specification. In addition, the procedure illustrates a systematic approach for the construction of MES models that can be used for verification and validation of the MES, a definition of MES characteristics and operations in a unambiguous and clear way, and description of MES from conceptual to detailed level according to the hierarchical structure of the systems activities, considering aspects such as modularity, flexibility and expansion capability. In the future, aimed to improve the present work, a general design procedure of MES considering a supervisory system will be presented.

7. Acknowledgements

This work received financial support of Brazilian agencies CAPES, CNPq and FAPESP.

8. References

- Aeberli, K. E.; Lee, Y. H.; Schafer, U., 2000, "Electrical and automation equipment in the new continuous pickling and cold rolling line at Dongbu Steel", *Metallurgical Plant and Technology International* (Germany). Vol. 23, no. 6, pp. 52-58.
- Anschuetz, H., 2001, "HPSim Copyright © 1999-2001", http://www.winpesim.de/petrinet/e/hpsim_e.htm.
- Chen C.; Dai J., 2004, "Design and high-level synthesis of hybrid controller", Proc. of IEEE Intern. Conf. of Networking, Sensing & Control, Taipei, Taiwan
- Deisenberger, K.; Kutschar, W., 2003, "Automation of POSCO's No 3 annealing and pickling line", *Steel Times International*. Vol. 27, No. 8, pp. 22-26.
- Frey, G.; Litz, L., 2000, "Formal methods in PLC programming", Proc. of the IEEE Conf. on Systems Man and Cybernetics, Tennessee, USA.
- Mader, A., Wupper, H., 2000, "What is the method in applying formal methods to PLC applications?", 4th Int. Conf. Automation of Mixed Processes: Hybrid Dynamic Systems (ADPM), Dortmund, Germany.
- Miyagi, P. E., 1996, "Controle Programável - Fundamentos do Controle de Sistemas a Eventos Discretos", Editora Edigard Blücher, São Paulo, SP.

- Miyagi, P. E., Arata, W. M., 1997, "Analysis of manufacturing systems – application on PFS model based analysis of manufacturing system for performance assessment", *Revista Brasileira de Ciências Mecânicas*, ABCM, Campinas, SP. Vol. 19, No.1, pp. 58-71.
- Murata, T., 1989, "Petri nets properties, analysis and applications", *Proceedings of the IEEE*, Vol.77, no.4, pp.541-580.
- Peng, S. S., Zhou M. C., 2004, "Ladder diagram and Petri-net-based discrete-event control design methods", *IEEE Transactions on Systems Man and Cybernetics - Part C Applications and Reviews*, Vol 34; No. 4, pp. 523-531.
- Peterson, J. L., 1981, "*Petri Net Theory and The Modeling of Systems*", Prentice Hall, Englewood Cliffs.
- Ramadge, P. J.; Wonham, W. M., 1989, "The control of discrete event systems", *Proceedings of the IEEE*, Vol.77, no. 11, pp. 81-98.
- Reisig, W., 1985, "*Petri Nets an Introduction*", Spring Verlag, New York.
- Takahashi, K.; Hasegawa, K.; Miyagi, P. E., 1999, "Hierarchical programming of sequential control systems by mark flow graph", Proc. 7th IEEE International Conference on Emerging Technologies and Factory Automation, Barcelona, Spain.
- Zurawski R., Zho M.,1994, "Petri net and industrial applications: a tutorial", *IEEE Transactions on Industrial Electronics*. Vol.41, no.6, pp.567-583.

9. Responsibility Notice

The authors are the only responsible for the printed material included in this paper