

## NOISE SYNTHESIS TECHNOLOGY : A TOOL FOR VIRTUAL NOISE PROTOTYPING

**Goran Pavić, goran.pavic@insa-lyon.fr**

Laboratoire Vibrations-Acoustique, Institut National des Sciences Appliquées  
20 avenue Albert Einstein, 69625 Villeurbanne, France

**Abstract.** *Noise Synthesis Technology (NST) is an approach aimed at low noise design of industrial products where noise is generated by individual sources implanted into a noiseless main frame (housing). NST addresses all major noise mechanisms in a systematic step-by-step procedure, simple enough for use even by less advanced industries. The originality of NST is that it predicts trends in the overall noise by combining data from real noise sources with a simplified modelling of the main frame. The underlying approach to such modelling is a modified sub-structuring technique. The simplified frame model has the advantage of being more robust and more easy to implement for the purpose of noise level prediction and oralisation. The paper outlines the basics of the NST approach and shows some industrial examples of its use.*

**Keywords:** *noise control, virtual prototype, source characterization, noise prediction, sound oralisation*

### 1. INTRODUCTION

Low noise design of industrial products is in demand and will likely stay so in future. Yet, only rarely companies have the means and resources to carry out comprehensive low noise design work by dedicating some major effort to noise modelling and prediction. Only the hi-tech companies with own R&D resources, such as automotive and aerospace, can afford to spend extensive (but rarely exceptional) means on noise control. Although the majority of industries cannot justify any laborious work dealing with noise issues, most of them nevertheless need to reduce the noise of own products in an orderly, systematic way.

Furthermore, the software for noise prediction cannot adequately respond to the complexity of noise generation, which usually gives these tools a secondary role of accompanying expensive prototyping. The noise software is difficult to use by industry and is limited to specific phenomena only. It does not cover the most important factor in the noise generation chain: the noise sources.

Management increasingly believes in replacing man by computer in all technical areas. The long-term managerial objective is to considerably reduce physical prototyping in exchange for a virtual one. The ultimate goal is to achieve an integral rather than a partial virtual prototyping, implying that all of the technical features, noise comprised, have to be dealt with numerically at the same design phase.

Current position of industry with respect to noise control of industrial products is globally governed by the following points:

- Reduction of time-to-market and rapid adjustments to changing markets.
- Need for pre-design information and accelerated prototyping.
- Technical teams lack understanding about the physics of noise and vibration.
- Most companies miss clear noise control strategy which forces them to apply late curative measures.

A complex product, such as a vehicle or a power machine, is made of many sub-assemblies originating from various suppliers. Suppliers usually do not feel concerned with the noise of assembled product while the assemblers sometimes formulate too unjustified demands on noise. Traditionally, suppliers and assemblers lack coordination on noise control. There is a profound shortage of available information on noise of components. Regulations concern finalised products only, not components. Noise generation often involves multiple phenomena, yet no design data exist on the link between vibration, pulsation and air-borne noise.

Noise of many of assembled products is governed by the operation of some key components, such as motors, pumps etc, integrated within an otherwise passive frame structure (housing). Under the operation of these components the assembled structure often amplifies noise. Typical examples of products which generate noise in this way are vehicles, household appliances, HVAC installations, outdoor machinery, communication equipment, computation equipment etc. In these and similar products noise is transmitted to the surroundings as direct air-borne noise, structure-borne noise (via feet, supports, cables etc) and frequently fluid-borne noise (via ducts, pipes etc). Although often being more detrimental than the first one, the latter two noise mechanisms are rarely dealt with seriously in industrial conditions. As a consequence, the noise reduction measures become inappropriate and thus inefficient.

A specific methodology of addressing noise control of industrial products, called NST, has been conceived within a multi-partner project "Nabucco" sponsored by the Commission of European Community. The principal goal was to come closer to the practical needs of typical industries which lack competence in the noise control area. A double objective was set: a) to provide tools for reducing noise by design and b) to make noise issues more familiar to the technical staff, often in charge not only of noise and vibration but of other technical areas as well.

The basis of the NST is the sub-structuring approach. A complex object (structure) is broken down to several components, the substructures, which are analysed separately in terms of their properties at the interface points. Once the substructures have been identified, the behaviour of the assembled structure can be obtained by imposing the continuity conditions at the interfaces. The principle is well known and used in various forms. Numerical methods of field analysis such as the FE method are an example of substructuring approach, the Statistical Energy Analysis (SEA) being another example.

Sub-structuring in the classical sense is useful when the numerical analysis of an entire structure is too large to be handled within a reasonable CPU time length or when a comparison of different local modifications of a structure is needed. Some fundamental theoretical grounds to the numerical substructuring techniques in dynamics were laid down over 4 decades ago (Hurty, 1965). Craig and Bampton (1968) have formulated a sub-structuring method for reducing the size of FE models using blocked boundaries. Berman (1973) has demonstrated how can condensation of a sub-structure model to its boundary state be carried out in the frequency domain. Hale and Meirovitch (1980) have formulated a general sub-structure synthesis method where the complexity of a given sub-structure is reduced using a low-order polynomial for its representation.

Within the context of NST, the substructuring is not used as a means of simplifying the modelling or reducing the computation effort, but as a basic means of getting the result in the first place. It is meant to reproduce on a computer the steps made by hardware prototyping. While the steps of sub-structure characterisation can be achieved either by computation or by measurements, the final synthesis has to be done by computation. Thus NST offers a major working flexibility: that of combining measurement and computation for a maximum of synergy.

Since the end of the "Nabucco" project, the NST was successfully used in other industrial projects. The purpose of this paper is to give a general outline of the NST technology while respecting the industrial confidentiality clauses.

## **2. VIRTUAL NOISE PROTOTYPING**

Classical noise prototyping, aimed at adjusting and improving the noise performance of the new product, usually comprises the following features:

- tests done on an assembled prototype
- different noise sources compared against each other
- use of absorption material and damping layers
- modification of connections & joints
- simple modifications of the main frame (stiffness ...)
- adjustment of source position and links within the housing.

The criteria to be fulfilled include:

- objective measurements, e.g. dBA level
- subjective perception: the noise quality.

A virtual prototype should enable carrying out the majority of these operations, not by physical means but rather using a computer. It is clear that such a prototype cannot be an entirely computer-based prediction tool. It has to include both fundamental aspects of acoustics: physical and subjective (psychological). The limits of the present day state of the art in noise prediction, while not far from satisfying the first criterion make the sound oralisation (audible sound reproduction) still many years off. This is so because the oralisation requires a high-level numerical prediction of the sound waveform arriving at the reception position which can be presently achieved neither using the finite/boundary element methods nor the statistical energy analysis in view of the limitations of these techniques.

A new product is usually an improvement over an existing line of products. The basic mechanical characteristics of the product affecting noise evolve gradually. This is typical of many products where complete redesign is rarely needed. Many of the components in the improved design will already physically exist, either in a final form or close to it, and their noise properties can be thus assessed by measurement. This brings the virtual noise prototyping within the reach of the present-day measurement and computation technology.

A virtual noise prototype offers a potential advantage over the classical prototyping: an improved physical insight which results from breaking down the analysed product into its components in a systematic way ("building bricks" approach). Not only the final result, i.e. the overall noise, can be assessed, but also it can be split into different contributions the importance of which can be judged in a far more straightforward way than if this has been attempted on a real prototype.

It is clear that a "virtual noise prototype" cannot be purely virtual, i.e. computer-generated, if its objectives are to be met. A considerable experimental work has to be done in order to make it work. This is the price to pay in exchange of tackling a considerable technological challenge: that of reproducing noise of a future assembled product. Even so, the virtual approach represents a considerable advantage as the needed experimental work relates only to different components prior to product assembling.

## **3. THE NST APPROACH: A PRAGMATIC SOLUTION TO VIRTUAL NOISE PROTOTYPING**

NST uses an evolution strategy for noise reduction. It builds on an existing generation of the product with the aim of improving its noise performance. Some generic acoustic properties of the products belonging to the same class (e.g.

home dishwashers) can be established from careful measurements or computation followed by some specific data processing. Once identified, these generic properties will be combined with data from real components – noise sources – in a computer analysis which will predict overall noise created by the assembled product. This should help the designer to synthesise the future product in a noise sensitive way: thus the name *Noise Synthesis Technology* (NST).

The first fundamental concept of NST is that of an active component – primary noise source – which generates noise through an interaction with the housing, i.e. its structural assembly. Within NST, a source is taken into account in a realistic rather than an abstract way, the latter being usually the case when the prediction is carried out by computation only. This is achieved by carefully extracting out of specific measurements the full noise information about the source – air-borne, structure-borne etc. The noise data are subsequently compacted, bearing in mind the coupling effects. The result is a noise descriptor, the Equivalent Source Strength (ESS), which characterises the source. One source will usually have several ESSs. Via the ESSs the noise source is supposed to be described by a minimum – yet complete – set of independent noise data. A descriptor is not necessarily noise, but some identifiable quantity, such as gas pulsations, responsible for noise generation. It should intrinsically represent the source, independently of any possible interaction of the source with its surroundings.

The second fundamental concept of NST is that of a Base Frame Model (BFM). A BFM is a synthetic structure, either physical or virtual, which represents in a simplified way the frame of a real industrial product. The role of any BFM is to provide information on noise transfer from the source(s), either directly or via the connections, and the frame structure to the listener's ear. In order to fulfil this role, a BFM has to have the same generic properties as the product it represents (e.g. a ventilation unit within a given product range all incorporate a housing and steel sheets of similar size, thickness, cross section etc.). The BFM thus represents an artefact which unites dislike noise generating mechanisms (air-borne, structure-borne, fluid-borne) on a common basis and, in addition, provides quantified data on noise transfer from the source to the listener's ears. The noise transfer data assume the form of Frame Conductivity Functions (FCF). Each FCF represents a transfer function between an excitation exercised by one particular source mechanism (defined by its BFM) and the sound at the listener's position due to this mechanism. If the noise due to some of generating mechanisms is transmitted via one or several connections, such as resilient mounts, the corresponding Connection Filter Functions (CFF) have to be inserted in between the BFMs and FCFs.

Once identified, the Equivalent Source Strength and the Frame Conductivity Function data are combined within a computer for carrying out the global noise prediction. Variation in current FCF parameters (e.g. characteristic mobility, modal density, damping) as well as variation in strength of different noise inputs from the source(s) are ultimately supposed to reveal the right measures for achieving noise reduction.

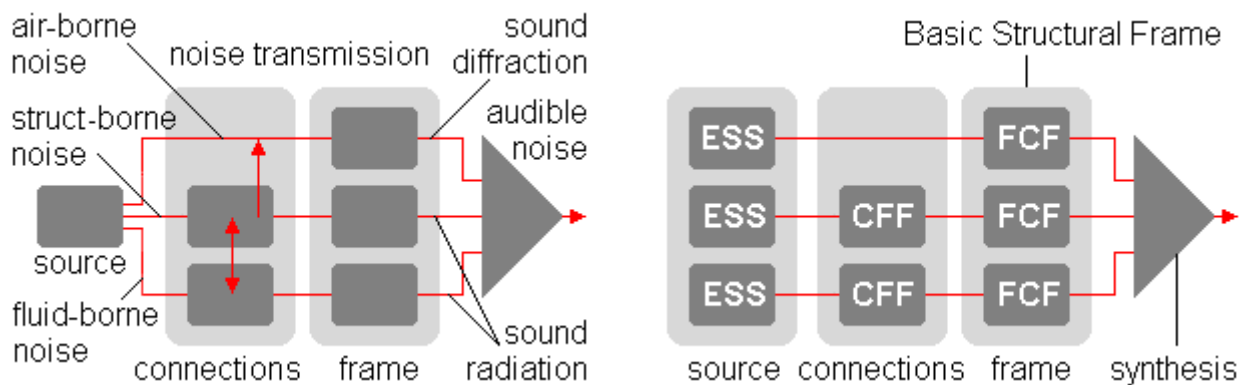

Figure 1. Noise Synthesis Technology: physical representation of noise generation (left) and its NST modelling equivalent (right).

When compared to alternative approaches, the Noise Synthesis Technology – if correctly applied - shows some advantages. Being based on a dual methodology, measurement + computation, it benefits from the realism of the former coupled to the prediction facility of the latter. Current noise prediction approaches do not integrate such a balanced duality. This however calls for skills in the areas of both computation and measurement.

Another big advantage is the realism in dealing with genuine, complex noise sources. This is rarely done nowadays, and never in the industrial sectors targeted by NST. In the other hand, the use of Base Frame for the representation of noise transmission will give predictions of a statistical rather than an exact nature, i.e. it will show tendencies rather than exact levels. But the statistical character of results is largely compensated here by an increased reliability that can rarely be attained when relying solely on computation methods.

Finally, the completeness of NST approach permits, where successfully applied, an audible reproduction of noise of the future product. This feature is meant to enable an assessment of sound quality of the product. The originality of NST approach as a noise control strategy is in that it places the noise source(s) and its integrating structure – the noise transmitter – in a concurrent position with the goal of synthesising, comprehending and improving the noise performance of the assembled product.

NST should not be regarded as a universal tool of noise reduction. NST is a technology which addresses some specific objectives, the most important of which is the acoustical interaction of the source(s) and the frame. While one of the principal NST outputs is the prediction of the resulting noise, any elaborate computation typically needed to achieve such an output is here replaced by modelling based on either comprehensive measurement, empirical formulae or simple analytical computations. This yields the NST more of a "feet-on-the-ground" approach which could be more appealing to industry than some current all-computer approaches. It should be recalled here that the objective of NST is not only to create a noise prediction result but is also to give to the user the chance to better understand the noise issues.

The NST framework can be resumed into several key points:

- In order to reduce noise of the assembled product, the designer may wish to replace an existing source with one which will create less *overall* noise. Furthermore he may attempt unsubstantial frame modifications for a more efficient noise reduction.
- Usually the product noise has a fairly irregular spectrum, decisively influenced by the source but additionally coloured by the vibroacoustic features of the frame. The latter usually exhibit an abundance of resonant peaks and dips, difficult to predict accurately.
- NST benefits from the physical existence of sources and frames which require improvement when assembled together. The approach is not meant to rely on any cumbersome or sophisticated computing, but should dominantly repose on the wealth of information which only need to be extracted from the existing components.
- The objective is to improve the final product by considering simultaneously the noise sources and the frame structure. The improvement consists in a) selecting the component(s) which best fits the whole assembly and b) in modifying the assembly for improved noise reduction.
- The definition of product noise should be done by the product assembler. In particular, the product assembler should specify the target quantity (SPL / power), position of reception point(s) w/r the object itself, test conditions (chamber size, absorption etc.) and product operating regime(s).
- The product modifications should be done primarily by acting on the frame and component connections. It should be possible however to also conceive modifications of the source(s) for an improvement of their generic vibroacoustic features.
- A user of NST technology will have a good overall knowledge of acoustics and vibration, but does not need to be a high-level specialist in acoustics.

#### 4. NST IMPLEMENTATION

To meet the NST goals, the sources and the frame have to depart via separate characterisation, only to be taken interactively at a later stage within a computer. While each source should be treated in a deterministic way - taken just as it is, the frame would usually be too detail-sensitive to allow for any reliable deterministic handling. NST makes a compromise by treating the frame as a combination of stable vibroacoustic features, driven by some basic design characteristics, and fuzzy (dispersed) ones emanating from structural details and production/installation uncertainties. Existence of uncertainties in the frame description will make the final results attainable in statistical terms: via an expected value and its deviation probability.

The prediction of product noise, selection of best components as well as of measures to be undertaken for structural modifications are done with the help of a multi-task software tool, the Noise Synthesiser, which is fed by input data obtained on the sources and on the frame. Two basic types of synthesiser output results are: synthesised noise in the form of band levels and audible noise waveform.

##### 4.1 Characteristics of a source – the ESS

The source is taken into account in a deterministic way, by establishing its detailed vibroacoustic characteristics e.g. via measurements. *Measurements are non-standardised and have to be adjusted to the requirements of NST technology.* Detailed characteristics have to provide NST-specific data: the Equivalent Source Strength (ESS). The source has to be characterised a way which is fully independent of its frame. This may not be an easy task, since an exact source characterisation is not easy, as shown by Bobrovnitskii and Pavić (2003). Here one has to find ways of simplifying the characterisation procedure, still keeping it independent from the reception structure. Sources like fans are particularly difficult to characterise independently, which calls for a good deal of simplifications (Berglund et al., 2002).

One component may have several ESS in dependence of how many independent noise generating mechanisms it incorporates. E.g. an electric motor fitted with a fan is likely to need two ESSs, one describing the excitation by the internal electromagnetic field which results in both air borne and structure borne noise, and another one to account for the aerodynamic fan excitation.

##### 4.2 Characteristics of the frame – the FCF

The frame structure is taken into account in averaged sense. This is done in order a) to cover a group of similar but not necessarily identical products and b) to recognize that the structure has uncertain parameters. The latter is often the case with light-weight assemblies such as vehicles or white goods, as shown by Kompella and Bernhard (1993). The

vibroacoustical characteristic of the frame is given as a sum of two values: one stable, called the *baseline* and one uncertain, called the *fuzz*. This characteristic, the Frame Conductivity Function, provides the acoustical response of the frame to unit excitation and thus represents the ordinary transfer function. One frame may have several FCF if more than one independent noise transmission paths exists across it. Even if one of these paths is a direct air borne path extending from the source to the listener's position, a separate FCF should be assigned to such a path.

The baseline characteristic reveals generic properties of the structure analysed, unperturbed by small structural changes. However, this characteristic does not represent an average response but only a constant (stable) part in the response. The fuzzy characteristic reflects the fact that structural detail and even circumstances may affect vibroacoustic behaviour. It defines the dispersion features of the individualised response spectra: the envelope around the baseline, the resonance density and the damping.

Two opposing cases are of particular interest: 1) frame resonances are sparse and 2) the resonances are dense. In the first case the frame response variation due to resonances enters the baseline characteristic, in the second case resonances affect only the fuzzy characteristic. The criterion for distinguishing between the two cases consists in observing resonance positions of similar frames or those of a single frame subjected to unessential structural perturbations: if these positions lead to a complete reversal of resonance maxima and minima then the second case applies.

The baseline and fuzzy functions form a complementary generic data pair. This pair is the same for similar frames. As a matter of fact, different frames are identified as being similar if their generic characteristics are comparable.

### 4.3 NST requirements

The identification of baseline and fuzzy characteristics is done by a) identifying usual response transfer functions and b) carrying out specific post-processing on these functions. As a rule, the step (a) will be done by measurements. Each FCF is obtained from raw transfer functions "acoustical response / mechanical or acoustical excitation". FCFs are complex functions, containing amplitude and phase data.

To assess the influence of structural modifications on noise transmission, but also to provide a receptor for source (ESS) identification if needed, a simplified model of the frame structure, the Base Frame Model, has to be produced. Its design should fulfil two criteria: a) its FCF's baseline must match those of real structures, b) it should allow for carrying out structural modifications.

A BFM will be as a rule a material object. While such an object would be workshop produced, in some cases the original structure itself could serve as a BFM, especially if the manufacture technology makes the production of a custom-built BFM impractical.

Unless the source impedance is substantially higher than the frame impedance, the frame excitation has to be computed using mobility matching rules applied to the interfaces source - frame. This will produce excitation acting on the frame which can be radically different than that of the source taken in isolation (ESS).

A major processing step in describing the frame consists in evaluating its baseline characteristic. This is done by fitting the raw data onto a prescribed type of a simple frequency function. The data are the transfer functions of the type response / excitation. In a lot of cases these data will be obtained by measurements. Here one can use the reciprocity principle in order to simplify the measurement and improve its accuracy. This principle, widely used in acoustics, has been summarised by Ten Wolde (1973) and Fahy (1995).

*NOTE: Ways of characterising ESSs and FCFs are not unique, thus any ESS has to be adapted to the respective FCF to ensure the needed compatibility!*

## 5. NOISE SYNTHESISER

The Synthesiser is a software which should enable the user of NST technology to carry out all the essential noise synthesis steps. The Synthesiser does not deal with the characterisation of either the source(s) or the frame. This has to be done outside the Synthesiser. Once these characteristics are evaluated, the Synthesiser takes over and does all the remaining NST operations. Within the Nabucco project a dedicated software, called PRONS, has been produced by Head Acoustics GmbH.

Role of the Synthesiser:

- Select the least noisy source(s) relative to the given product
- Rank different noise transmission paths
- Predict product noise
- Get an appreciation of product noise quality
- Assist in the analysis of noise reduction

Basic functions of the Synthesiser:

- Establish NST model topology
- Produce noise spectrum of the assembled product
- Synthesise product noise for audio reproduction.

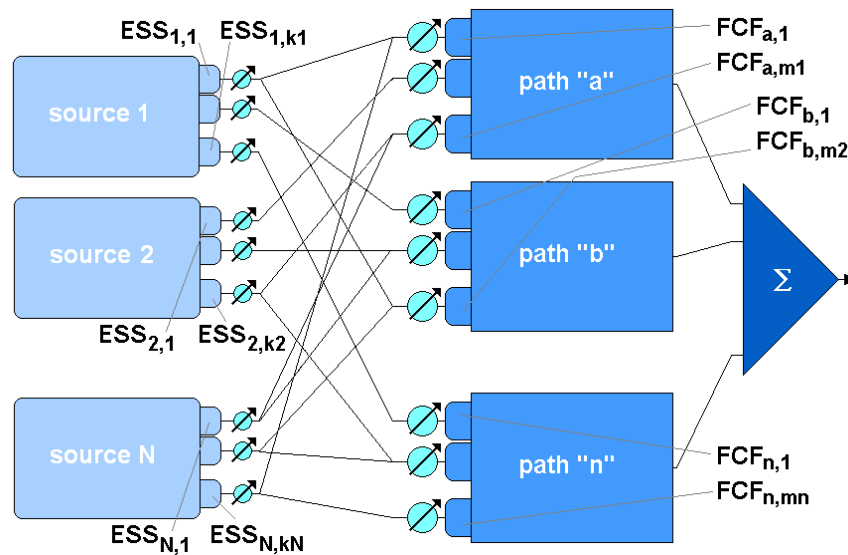

Figure 2. Noise Synthesiser block diagram

Basic Synthesiser operations:

- Configure NST model appropriate to the product analysed
- Carry out impedance matching of the component(s) to the structure
- Compute output noise spectrum from the supplied ESS and FCF data
- Introduce variations in FCF functions for noise sensitivity analysis
- Enable blending of different noise path contributions
- Synthesise noise waveform from component waveform + FCF spectral inputs
- Estimate noise waveform from spectral data
- Check data format & consistency, enable data conversion.

Apart from cases of simple air-borne sources, an ESS is likely to change when the source is incorporated into the frame. The ways to account for such changes are well known. One possible way is to apply the impedance concepts to the continuity conditions. A summary of how the air-borne, structure-borne and fluid-borne continuity should be applied in the NST approach is described by Pavić (2000) in one of the reports of Nabucco project. A description of a practical NST application to electric motors as noise sources was done by Moorhouse and Pavić (2004). Three basic cases are:

- The source impedance is much higher than the frame structure impedance, in which case the ESS stays unaffected by the structure.
- The source impedance is much lower than the structure impedance, in which case the ESS is reduced by a factor equal to the ratio of two impedances.
- None of the two above mentioned conditions applies (most often condition), in which case the ESS is modified by a factor  $1 + \text{ratio structure/source impedances}$ , Figure 3.

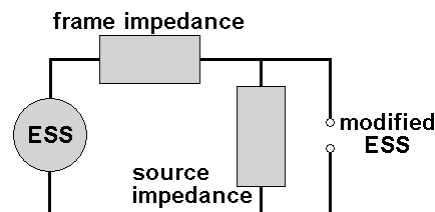

Figure 3. Source interfacing scheme

The output noise spectrum will be the sum of ESSs, reduced as appropriate, weighted by the corresponding FCFs. The spectrum can be either narrow-band or band-averaged. *Note: any ESS may affect several FCFs.* The summation of different pairs of ESS/FCF contributions to the resulting product noise should allow for individual “volume” settings in order to enable an assessment of modifications in one or several sources or transmission paths.

Audible noise synthesis can be accomplished via different algorithms: Fourier Transform, convolution etc. *Note: if impedance matching is needed, the impedance weighting function should be coupled to the FCF function.*

Ideally a synthesiser will be capable of extracting the baseline characteristic out of raw FCF frequency data. This procedure, called the frequency smoothing, is a necessary step for improving the robustness of results. It is discussed in some more detail in §7.

## 6. EXAMPLES OF NOISE SYNTHESIS

### 6.1 Computer simulation

Fig. 4 shows an example of the noise spectrum of a test frame structure subjected to a multi-harmonic excitation. It was obtained by computer simulation. The frame was a rectangular plate radiating into a semi-infinite space.

The dotted line represents the true spectrum, the peaks are denoted by circles. Thin full line represents the spectrum obtained by 1/3 octave frequency FCF smoothing with the peaks denoted by asterisks. The thick line represents the simplified smoothed spectrum obtained by neglecting interference between noise transmission paths.

In this particular example the differences between the true and the smoothed spectrum is quite substantial due to harmonic character of the excitation. However, the listening tests have shown that even so the sounds obtained directly and by NST synthesis procedure compared well. It was further shown that the variations as high as  $\pm 20\%$  of plate area and its aspect ratio produced no appreciable difference in sound perception. This conclusion applies to both stationary and transient sounds.

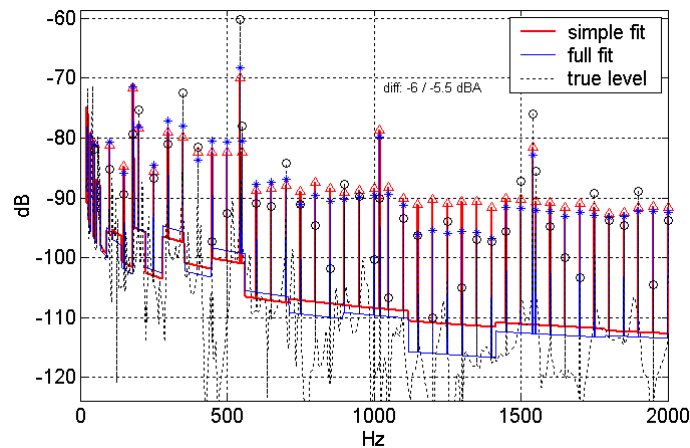

Figure 4: Spectra of a test structure obtained by computer simulation.

### 6.2 Real product: an electronic apparatus

Fig. 5 shows the exterior noise spectrum of a large electronic apparatus displayed in 1/3 octave format. The noise source was a cooling fan located within the metallic cabinet. The ESS of this source was measured separately in a specialised test rig as described by Moorhouse et al. (2003). The FCF was also measured separately, in an anechoic chamber. Reciprocity was used to facilitate the measurements.

Each 1/3 octave level is displayed by 3 bars: the left one representing the synthesised noise obtained by band linear smoothing, the middle one obtained by the simplified smoothing procedure and the right one obtained by direct measurement. A fairly good matching can be seen between the synthesised and measured values.

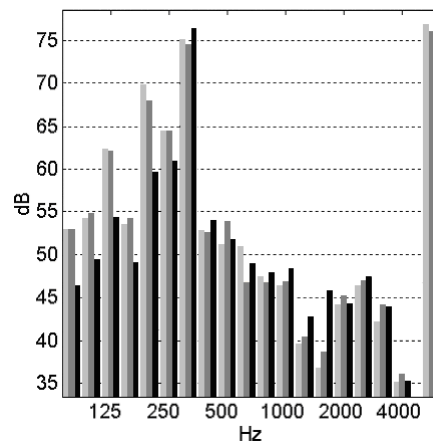

Figure 5: Synthesised (grey bars) and measured (black bars) noise of an electronic apparatus. Light grey: standard NST synthesis, dark grey: simplified NST synthesis by neglecting interferences between components.

## 7. FCF SMOOTHING: A KEY TO SUCCESSFUL NOISE SYNTHESIS

The statistical average of frame characteristic, the Frame Conductivity Function (FCF), is obtained within NST by replacing the original FCF of a single frame, or a set of original FCFs of several similar frames, by a simple band-averaged function.

An example illustrated by Fig. 6 shows the case of a typical frame structure: a household refrigerator cabinet. Three smoothing band widths were applied: 20, 100 and 500 Hz. The choice of the smoothing band is shown to play a major role regarding the level of fuzz but also regarding the robustness of the FCF function. Narrowing the band width reduces the fuzz but reduces the robustness too.

Linear smoothing used in this example consists of replacing a continuous transfer function by a series of piecewise linear segments (appearing as curved in dB scale) of constant frequency width. The segments are adjusted in such a way to the energy equivalence between the smoothed function and the original. The fitted function obtained in this way represents the FCF baseline. The difference of the actual and baseline values is used for an evaluation of the fuzzy part of FCF.

The figure shows the baseline and the standard deviation of the FCF fuzzy part fitted from the measured acoustic pressure transfer function of the type sound / force. Each of the three plots shows the same function but smoothed by different band widths.

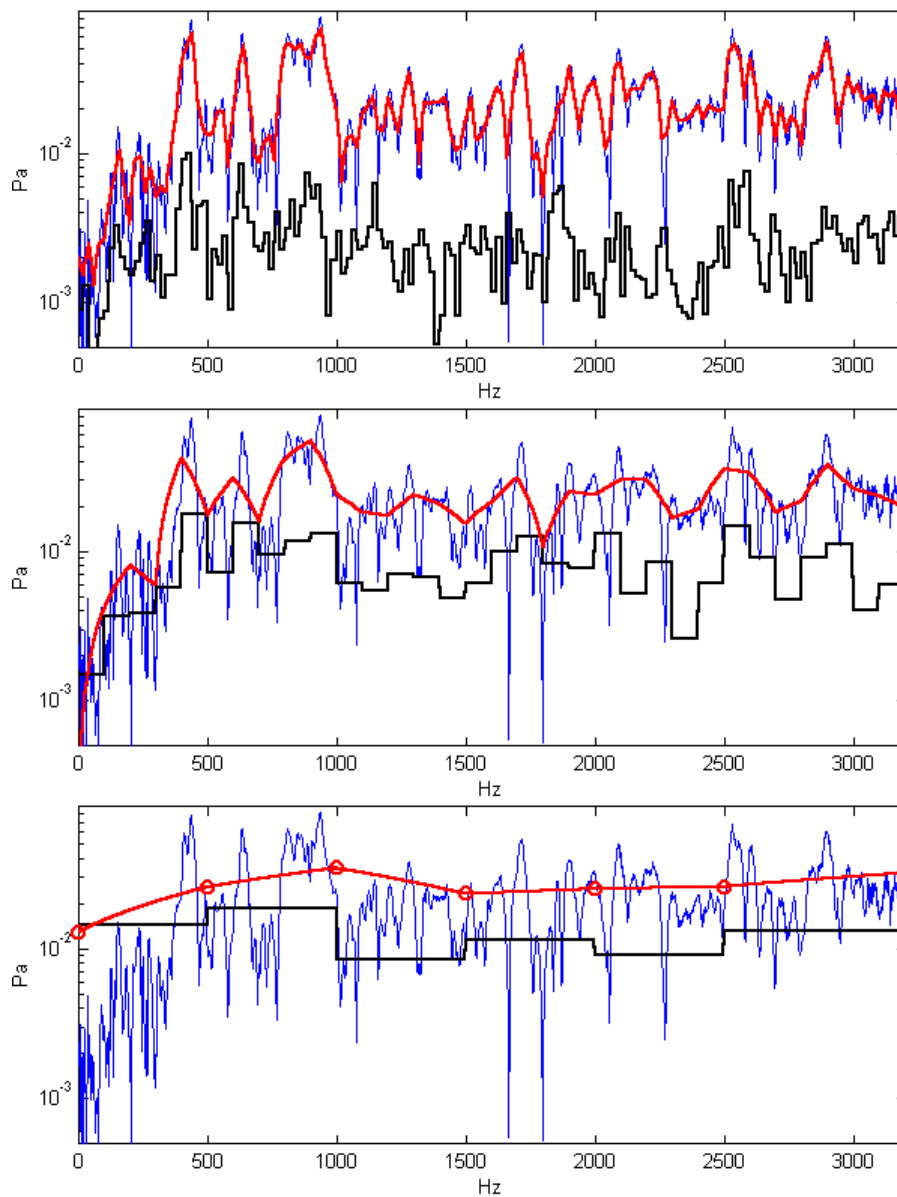

Figure 6: Constant bandwidth linear smoothing applied to a refrigerator cabinet. Bandwidth: top 20 Hz, middle: 100 Hz, bottom: 500 Hz. Blue line: original TRF; red line: FCF baseline; black line: standard deviation of FCF fuzz.

Decrease of frequency fitting band improves the matching of baseline to the original transfer function and consequently lower standard deviation of fuzz. Narrower frequency band width will however produce data which will



be less robust (more sensitive to small perturbations of the frame structure), thus a tradeoff will be needed in each case to select an optimum averaging band.

Fig. 6 shows three types of candidate simple functions which were found to correspond well to the needs of an NST analysis: 1/3 octave, constant bandwidth and piecewise linear. The smoothed FCF are obtained by conserving the energy level of the given function within each band. While the Figure shows the FCF modulus only, it should be remembered that the smoothing applies to both the modulus and the phase.

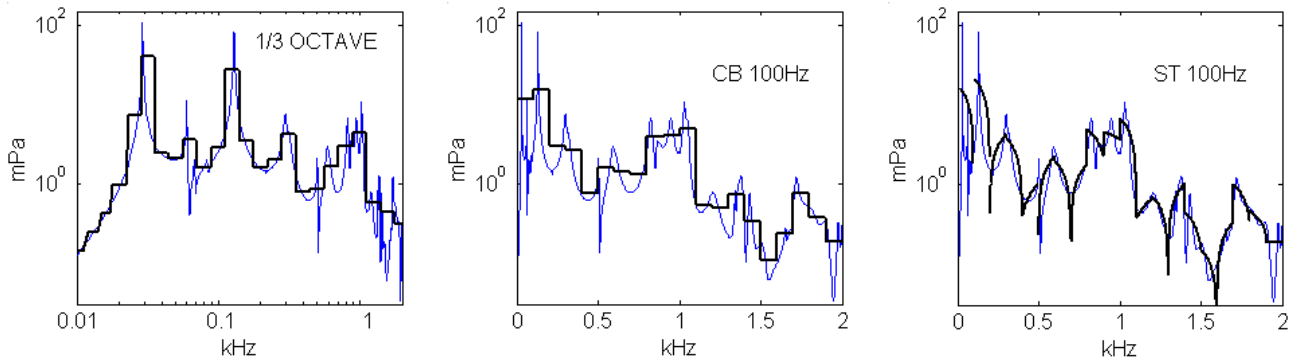

Figure 6. Three FCF smoothing functions: 1/3 octave (left), 100Hz constant bandwidth (middle) and 100Hz piecewise linear (right). Thin line: original FCF, thick line: smoothed FCF.

Synthesis of audible product noise can be done in two ways: via conversion of frequency noise spectra into time domain using simplified hypotheses (basic synthesis procedure) or via appropriate integral transforms of original noise source waveforms - temporal ESSs records. Ideally, the conversion of input data into noise would require knowledge of the interaction between different ESS mechanisms - air-borne, fluid-borne and structure-borne - and between different excitations within the same mechanism. Very often different mechanisms will be uncorrelated while the effect of interaction between different excitations on resulting noise will be negligible in comparison to the direct contribution of these excitation, all of which will simplify the Synthesiser analysis.

Each particular type of product should be studied on its own in order to find out which smoothing procedure best fits the properties of its transmission paths.

## 8. CONCLUSIONS

NST technology serves for an improvement of noise performance of industrial products which are composed of one or several primary sources incorporated into a structural frame. Any application of NST to a particular industrial case requires specific information on the component(s) - ESS, and specific information on the frame structure - FCF. In a long-term application of NST technology, the component manufacturer will be supposed to provide ESS data related to his products by himself.

ESS and FCF are complex, frequency dependent functions. ESSs are specified in a unique deterministic way, while FCFs are given in terms of averaged values - baseline, supplemented by the dispersion of these values - fuzz. The predicted noise spectrum will be given consequently in terms of its baseline and its standard deviation.

ESSs are measured on the operating component itself, while FCFs are either computed or reconstructed from the measurements done on a simplified structural model. In order to convert raw measurement or computation structural data into FCFs, frequency smoothing is needed to extract the baseline and compute the fuzz.

Component ESS data and structure FCF data serve as inputs to noise prediction and synthesis which is done by a specialised software: the Noise Synthesiser. Prediction of output RMS noise spectrum of the assembled product is done by the Synthesiser via classical sub-structuring techniques.

The described approach is supposed to serve as tool of low-noise design but also as a didactic means of letting the operator come in a closer touch with the noise of the products being developed. It thus gives the industry acoustician an active role in the area of noise control and design.

## 9. ACKNOWLEDGEMENT

One part of work described in this paper was supported by the Commission of the European Communities within the project GRD1-1999-10785 "Nabucco".

## 10. REFERENCES

1. Berglund, P.-O., Feng, L. and Åbom, M., 2002, "An application of the noise synthesis technology (NST) to a system with an axial fan", Proceedings of Forum Acusticum, Sevilla, Spain.

2. Berman, A., 1973, "Vibration analysis of structural systems using virtual substructures", *Shock and Vibration Bulletin*, Vol. 43, No. 2, pp. 13-22.
3. Bobrovnikskii, Yu. and Pavić, G., 2003, "Modelling and characterization of airborne noise sources", *Journal of Sound and Vibration*, Vol. 261, No. 3, pp. 527-555.
4. Craig, R.R. Jr. and Bampton, M.C.C. 1968 "Coupling of substructures for dynamic analysis", *AIAA Journal*, Vol. 6, No. 7, pp. 1313-1319.
5. Fahy, F.J., 1995, "The vibro-acoustic reciprocity principle and applications to noise control", *Acustica*, Vol. 8, No. 6, pp. 544-558.
6. Hale, A.L. and Meirovitch, L., 1980, "A general substructure synthesis method for the dynamic simulation of complex structures", *Journal of Sound and Vibration*, Vol. 69, No. 2, pp. 309-326.
7. Hurty, W.C., 1965, "Dynamic analysis of structural systems using component modes", *AIAA Journal*, Vol. 3, No. 4, pp. 678-685.
8. Kompella, M.S. and Bernhard, B.J., 1993, "Measurement of the statistical variation of structural acoustic characteristics of automotive vehicle", in *Proceedings of the SAE Noise and Vibration Conference*, Warrendale, USA.
9. Moorhouse, A.T., Berglund, P.-O., Fournier, F. and Avikainen, T., 2003, "Fan characterisation techniques", *Proceedings of Fan Noise 2003*, Senlis, France.
10. Moorhouse, A.T. and Pavić, G., 2004, "Virtual acoustic prototypes of white goods products", *Proceedings of Inter-noise 2004*, Prague, Czech Republic.
11. Pavić, G., 2000, "Preliminary conception of NST models", *Technical report*, Centre Technique des Industries Mécaniques, Senlis, France.
12. ten Wolde, T., 1973, "On the validity and application of reciprocity in acoustical, mechano-acoustical and other dynamical systems", *Acustica*, Vol. 28, No. 1, pp. 23-32.

## **11. RESPONSIBILITY NOTICE**

The author is the only responsible for the printed material included in this paper.